

Oct / Nov 2023  
Maths IGCSE  
ต้องได้ A\* หรือ 9  
เท่านั้น



## คอร์สตะลุยโจทย์

Intensive Maths IGCSE  
booster Oct Nov 2023

ด่วนรับเพียง 15 คนเท่านั้น !!

- ☑ เนื้อหาอัดแน่นจากทีมครุคุณภาพที่ครุคู่
- ☑ เน้นเทคนิคการทำข้อสอบรวมถึงการตอบคำถาม
- ☑ เข้มข้นด้วยการวิเคราะห์ข้อสอบ
- ☑ แนวข้อสอบที่หลากหลายและสมบูรณ์ที่สุด
- ☑ **FREE!** วิดีโอสำหรับทบทวนย้อนหลัง

Cambridge International

Date & Time  
Saturday to Sunday  
9-10, 16-17 Sep 2023  
9:00-12:00 am. / 1:00-4:00 pm.

Edexcel

Date & Time  
Saturday to Sunday  
23-24, 30 Sep, 1 Oct 2023  
9:00-12:00 am. / 1:00-4:00 pm.

HOT  
PRICE!

19,260-



## Part \*KruSie\*

### Content

- ✓ Angles and circle theorems. Page 1
- ✓ Circles and sector. Page 56
- ✓ Mensuration ( perimeter, area, volume ) Page 72
- ✓ Pythagoras and Trigonometry. Page 133
- ✓ Compound measurement and  
Travel time graphs. Page 178
- ✓ Symmetry. Page 192
- ✓ Construction. Page 213
- ✓ Transformation. Page 227

# Angles and Circle theorem



By .... Kru ชี

1. Acute angle

2. Obtuse angle

3. Right angle

4. Straight angle

5. Reflex angle

6. Angle at point or angle around point

**Vertically opposite angles are equal**

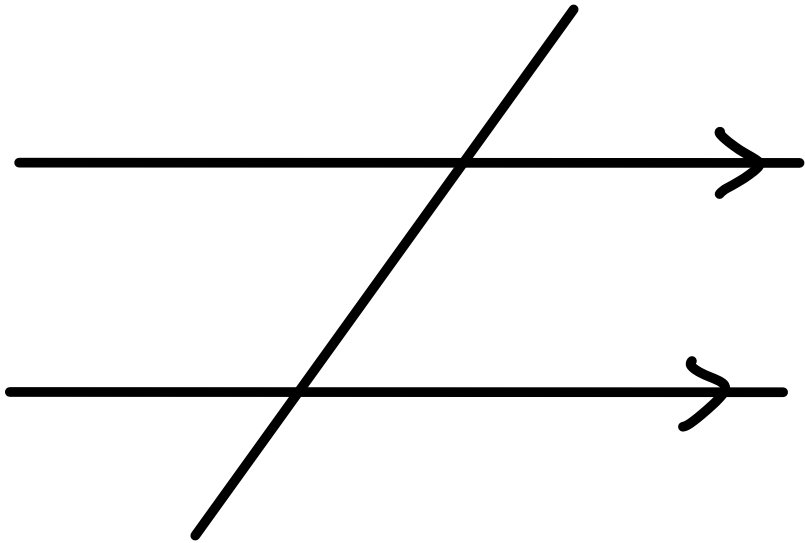

1. Corresponding angles are equal

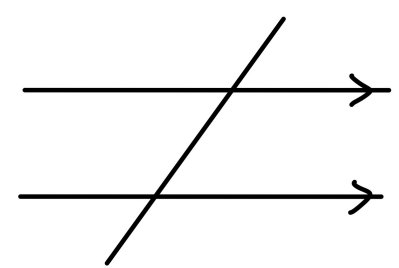
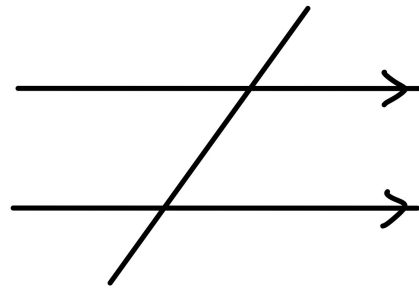
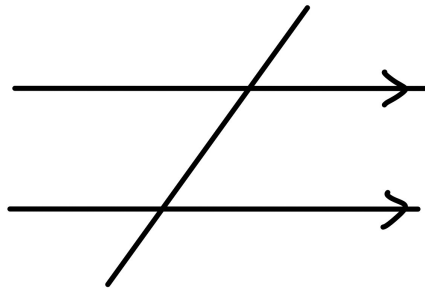
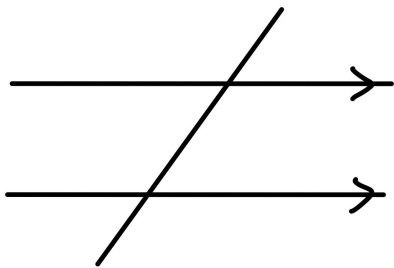

## 2. Alternate angles are equal

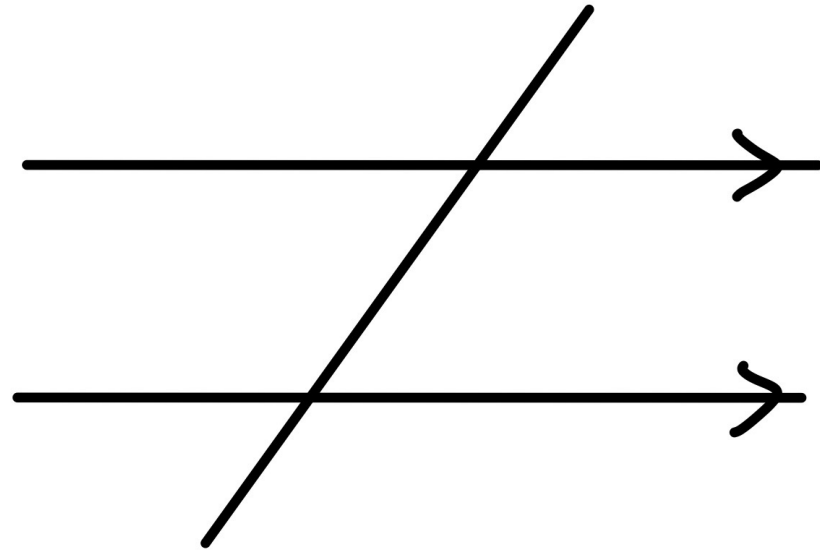
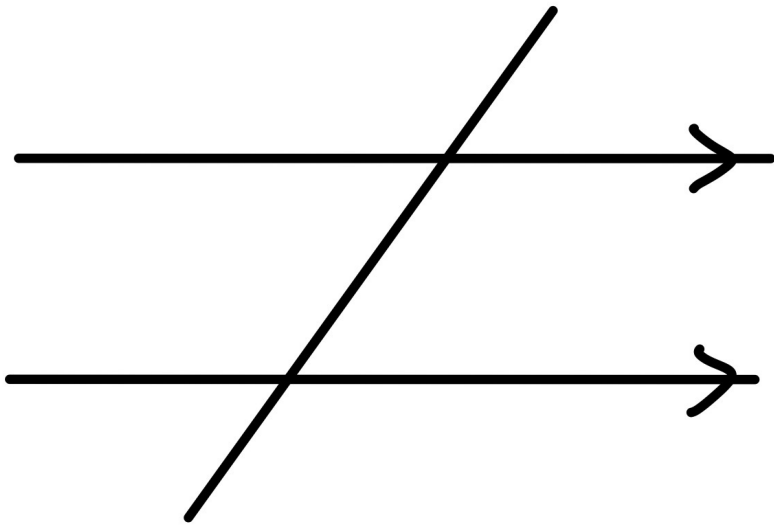

### 3. Co-interior angles add up to 180 degree ( allied angles)

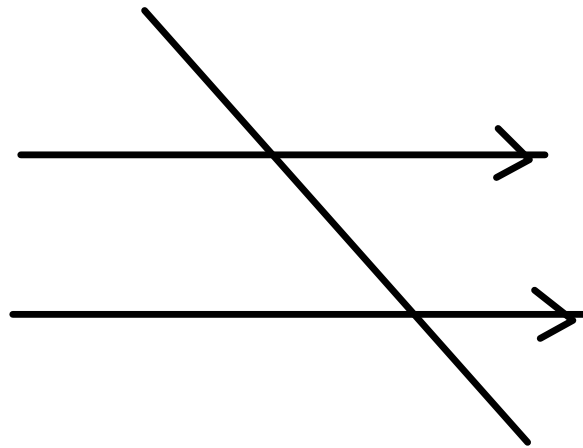
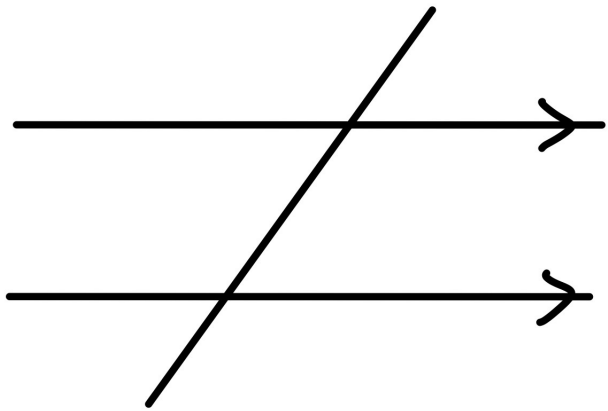

# Bearing

Find the bearing of A from B

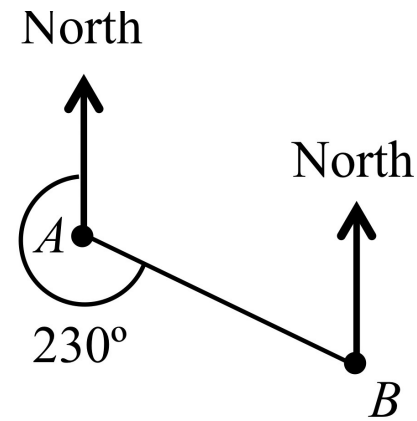
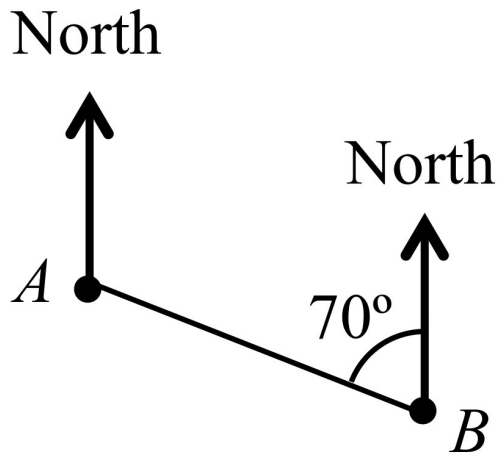

## Names of polygons

3 sides = Triangle

4 sides = Quadrilateral

5 sides = Pentagon

6 sides = Hexagon

7 sides = Heptagon

8 sides = Octagon

9 sides = Nonagon

10 sides = Decagon

11 sides = Undecagon

12 sides = Dodecagon



When  $n$  is number of sides in Polygon

$$\text{Sum of interior angles} = 180 \times (n-2)$$

For regular polygon , you can find each interior angle

Because each angle is equal



$$\text{One interior angle} = \frac{180 \times (n-2)}{n}$$



Sum of exterior angles in any polygon  
is always **360** degree



For regular polygons

$$\text{One exterior angle} = \frac{360}{n}$$

 For regular polygons

$$\begin{aligned} \text{Number of sides of polygons} \\ = \frac{360}{\text{exterior}} \end{aligned}$$

# 1. The isosceles triangle , when 2 sides are radius

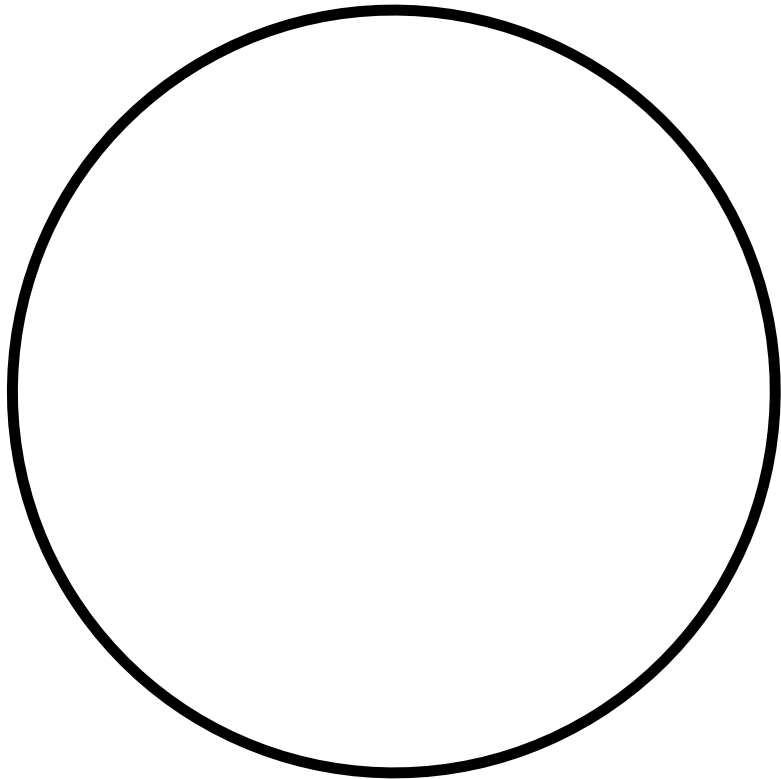

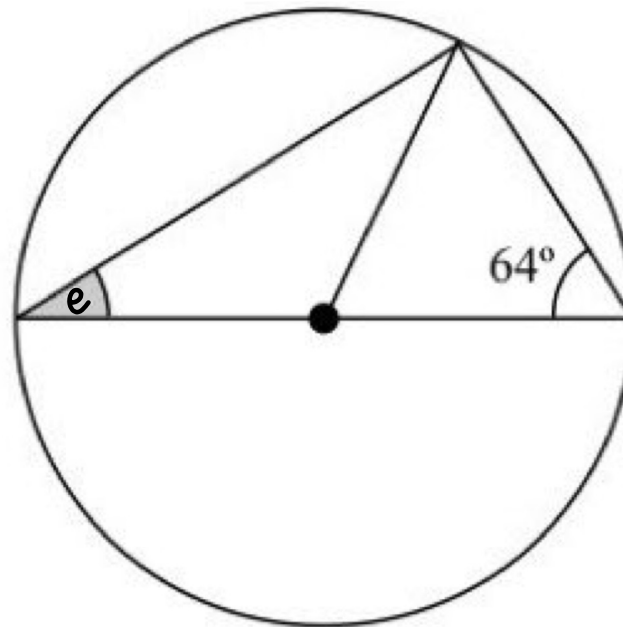
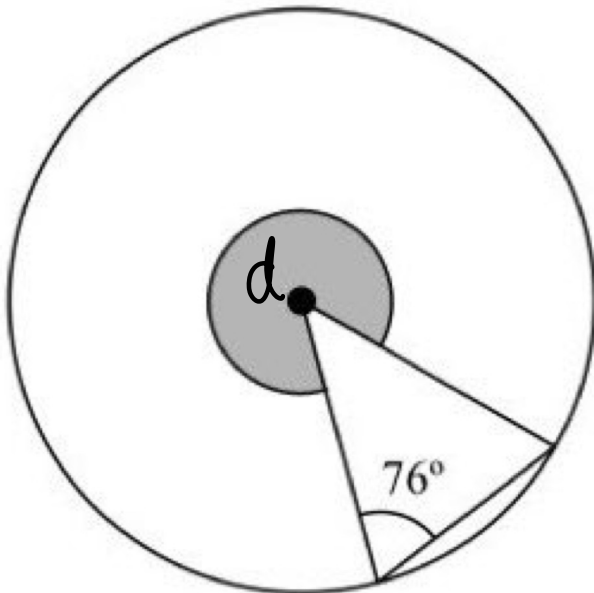
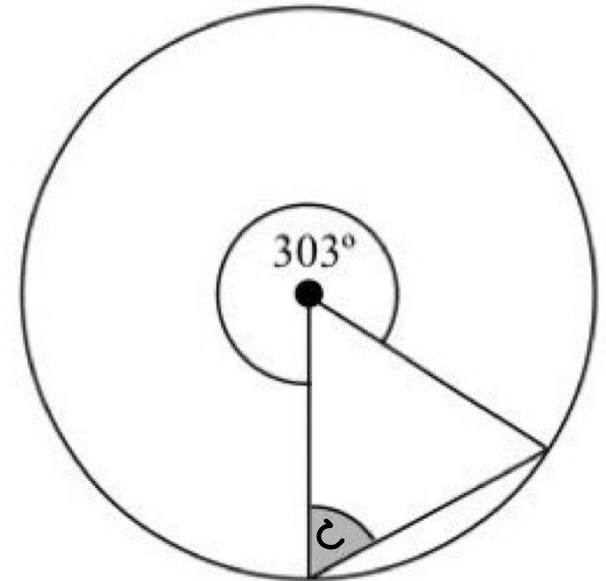
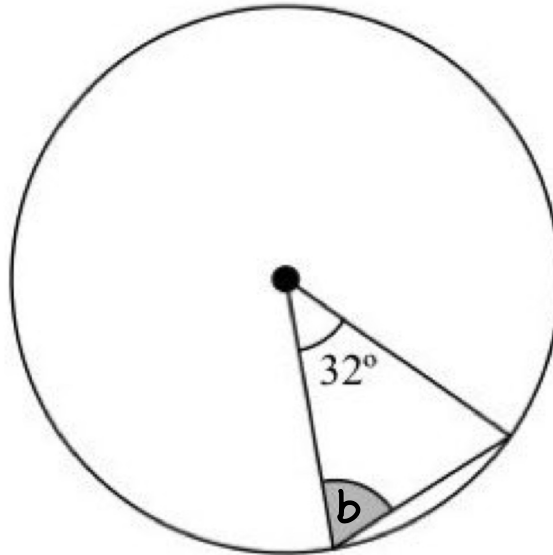
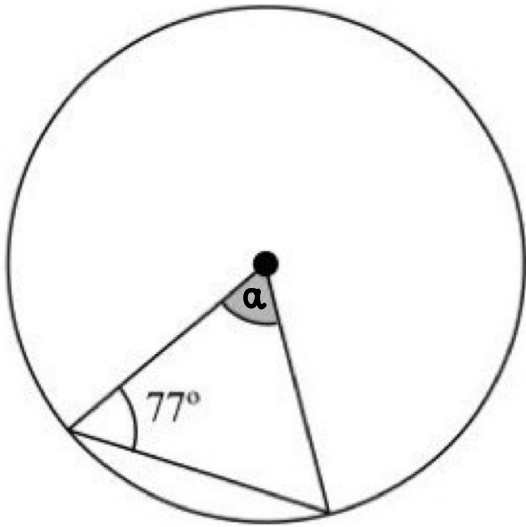

## 2. Angle in semicircle is $90^\circ$

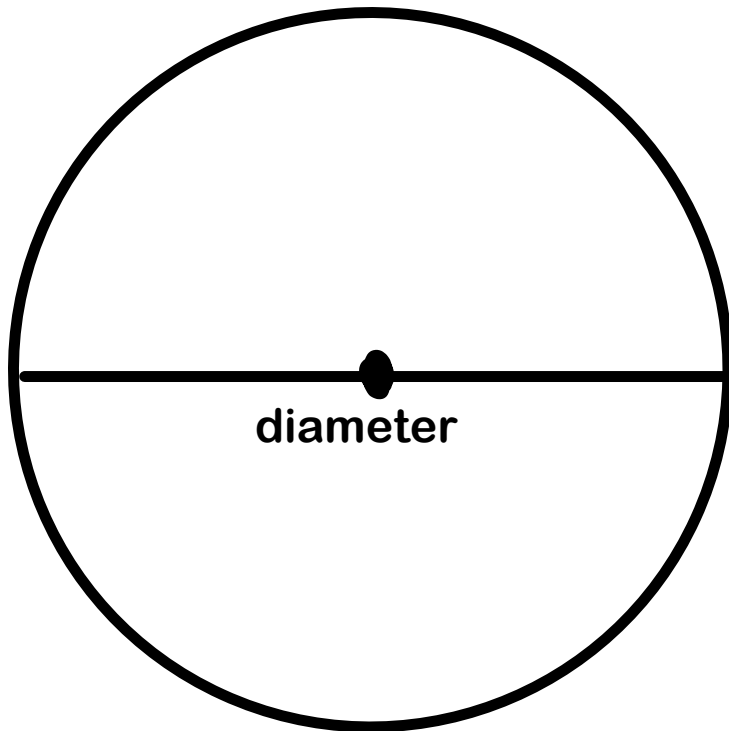

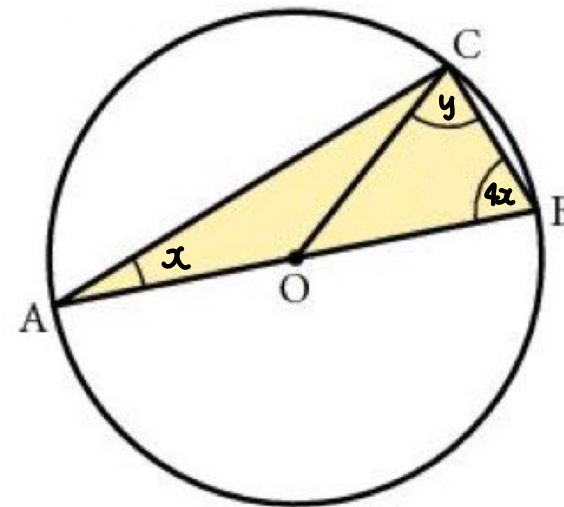
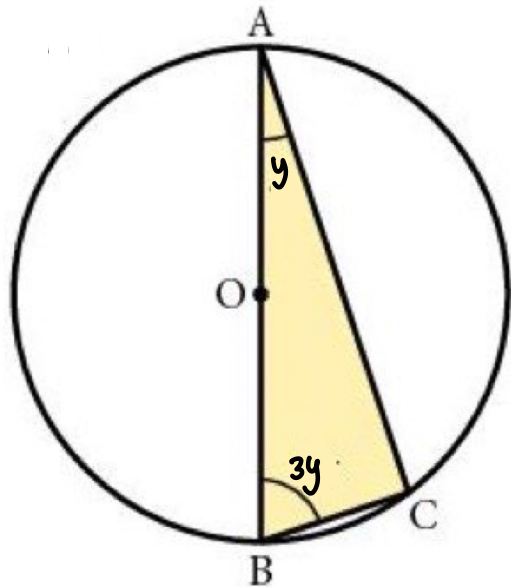
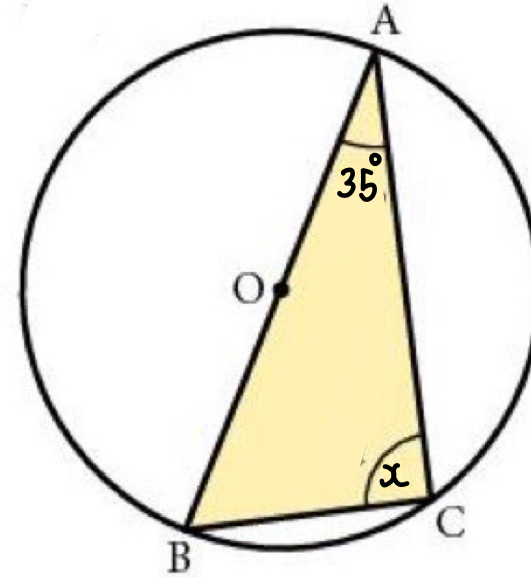
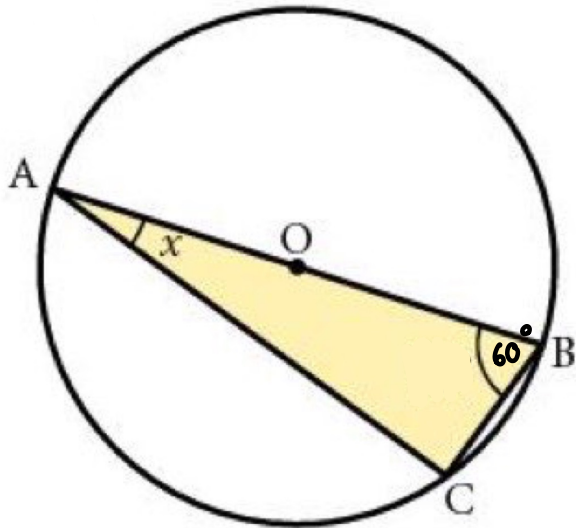

3. Angle at the centre is twice of angle at the circumference

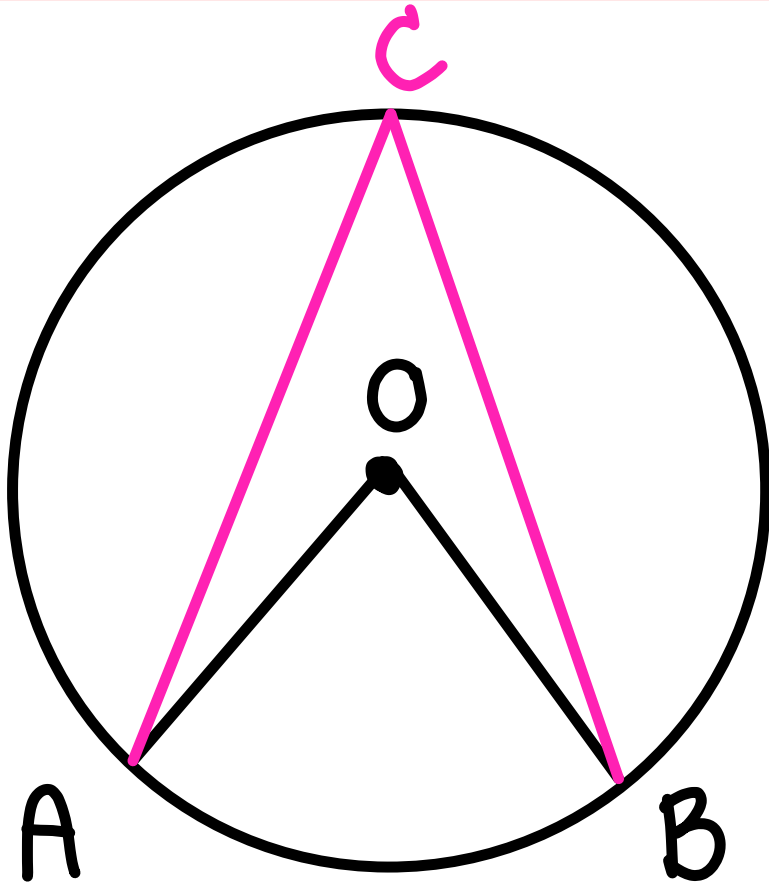

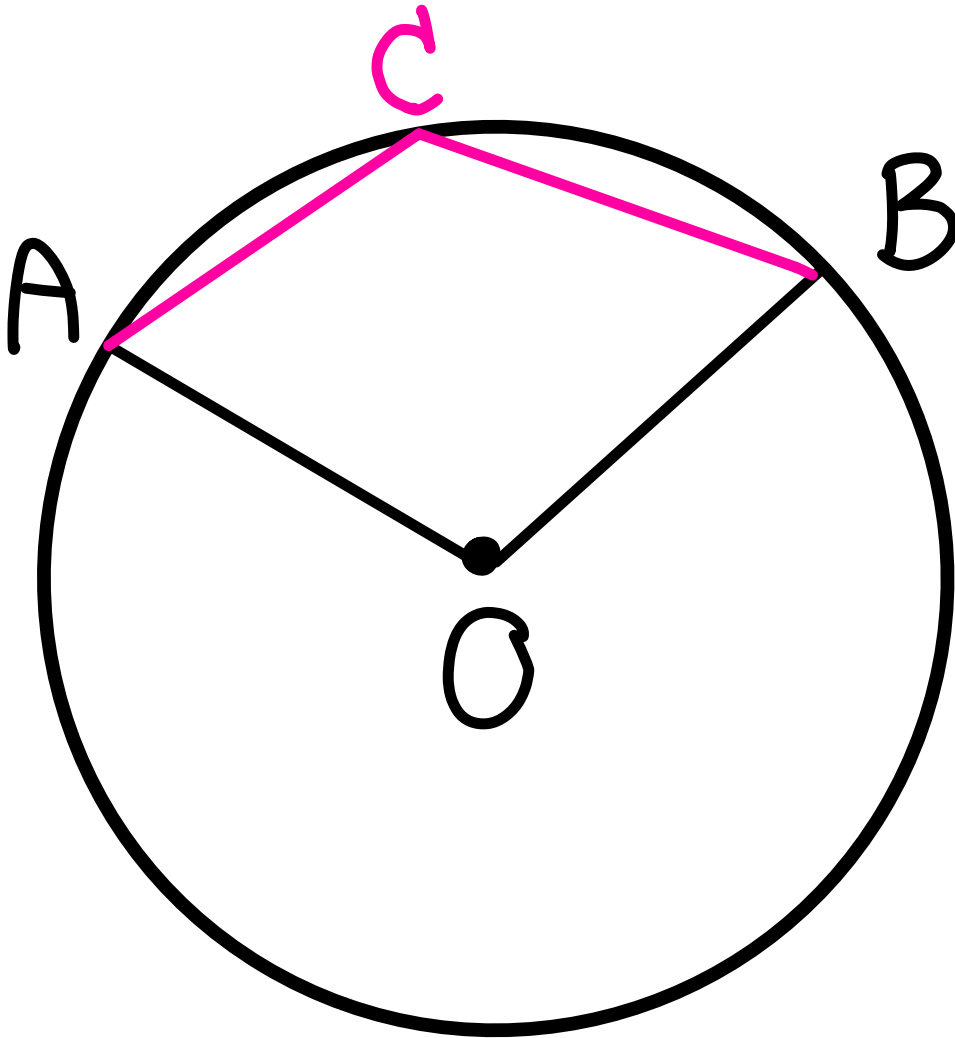

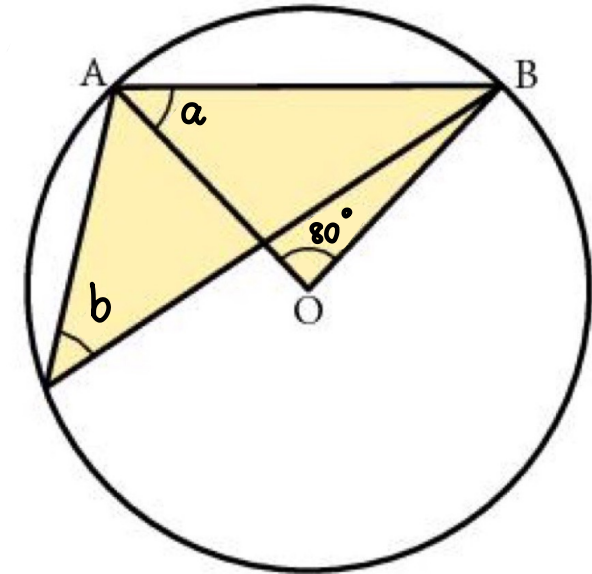
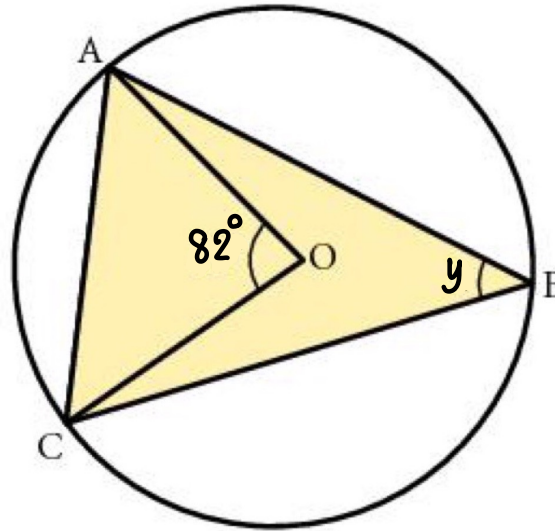
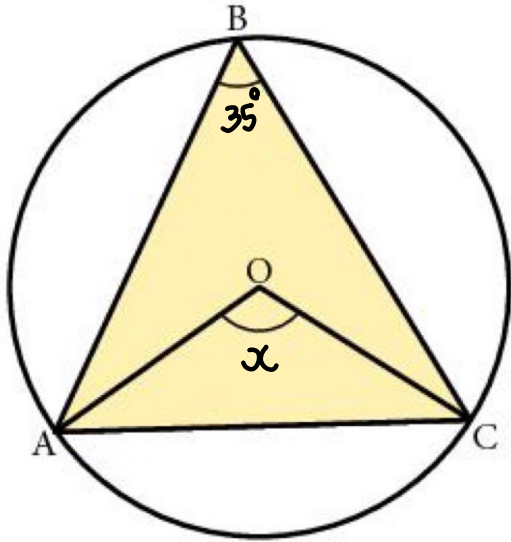

## 4. Angles in same segment are equal

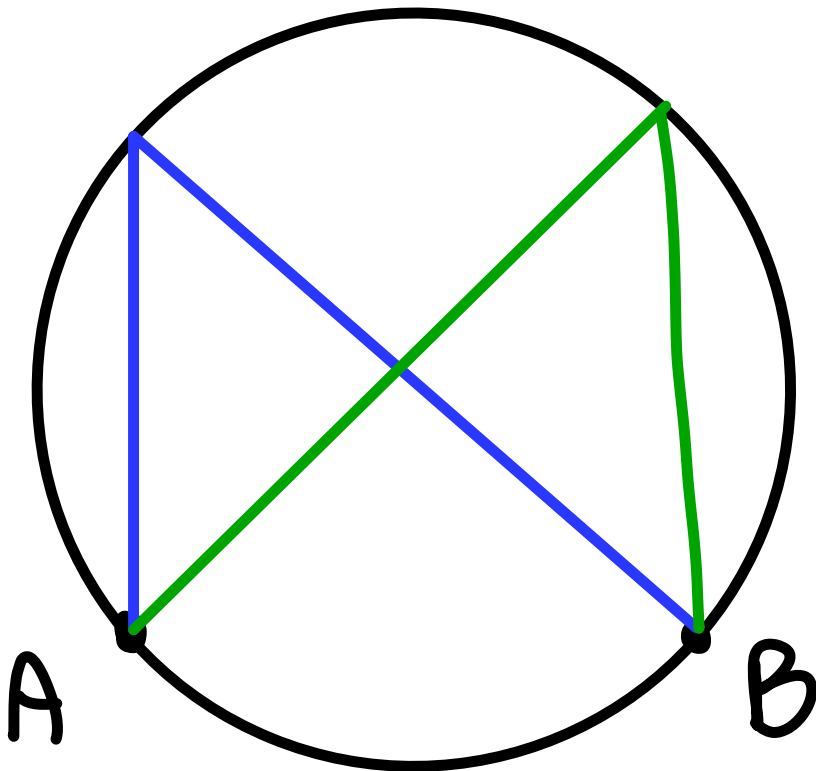

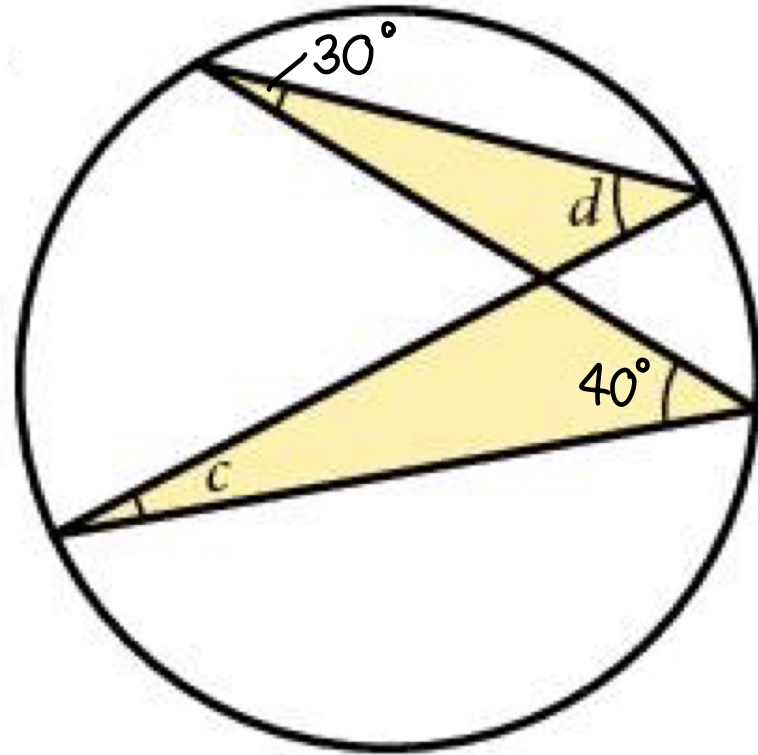
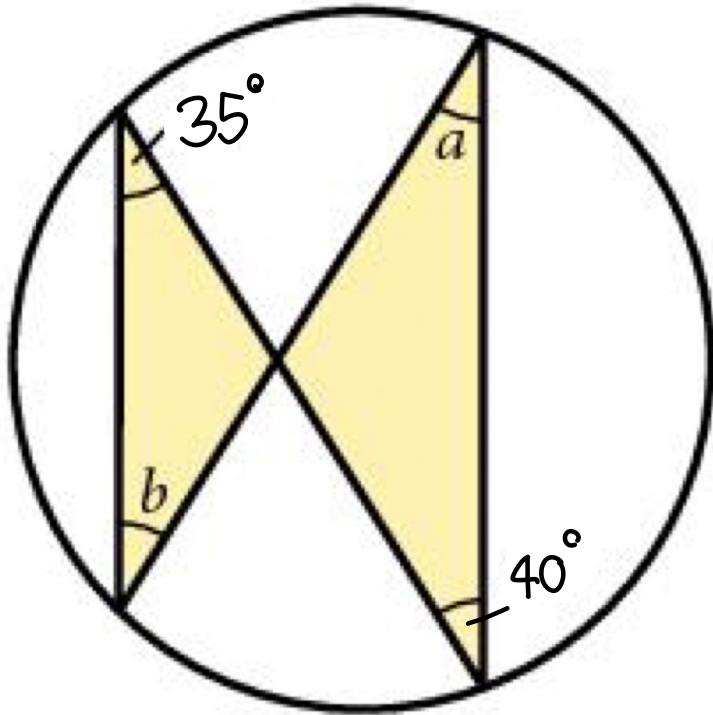

## 5. Opposite angles in cyclic quadrilateral add up to $180^\circ$

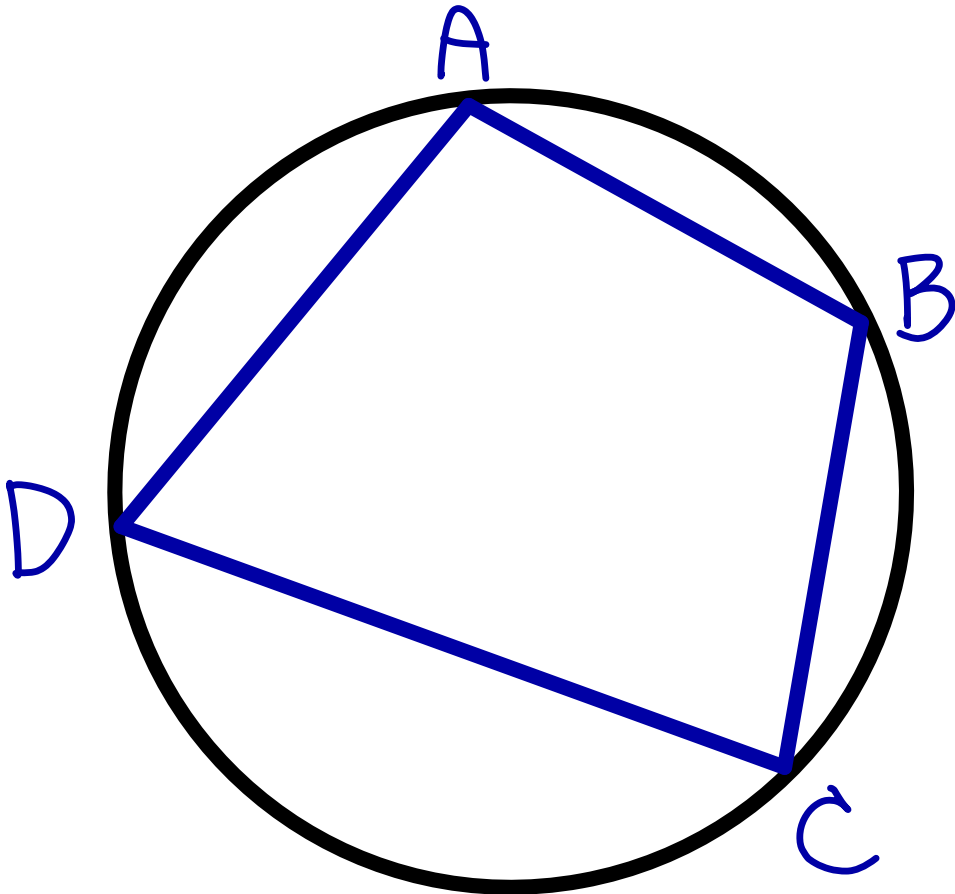

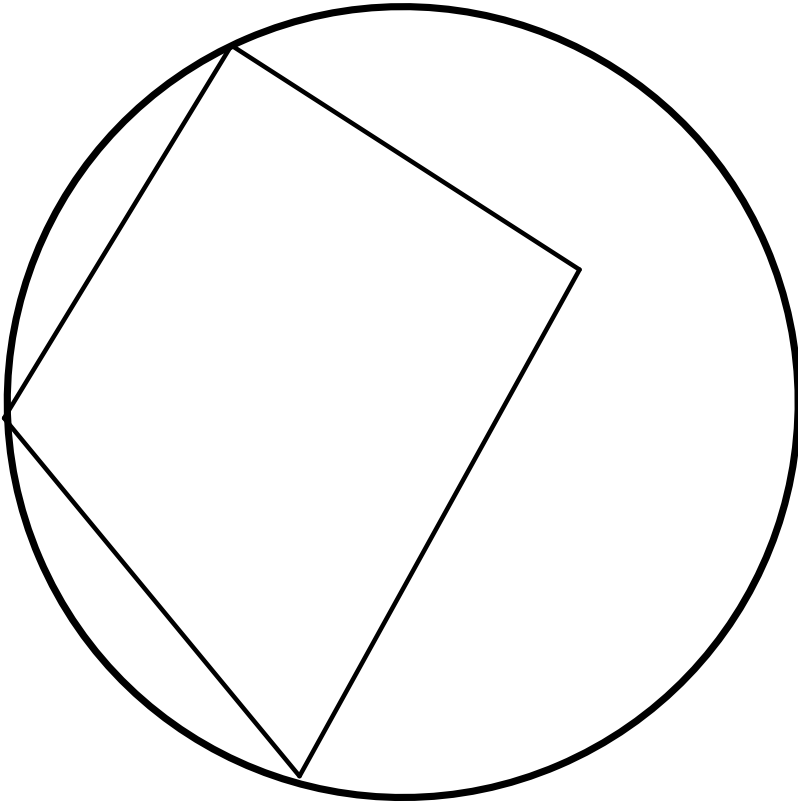

**Not cyclic quadrilateral !**

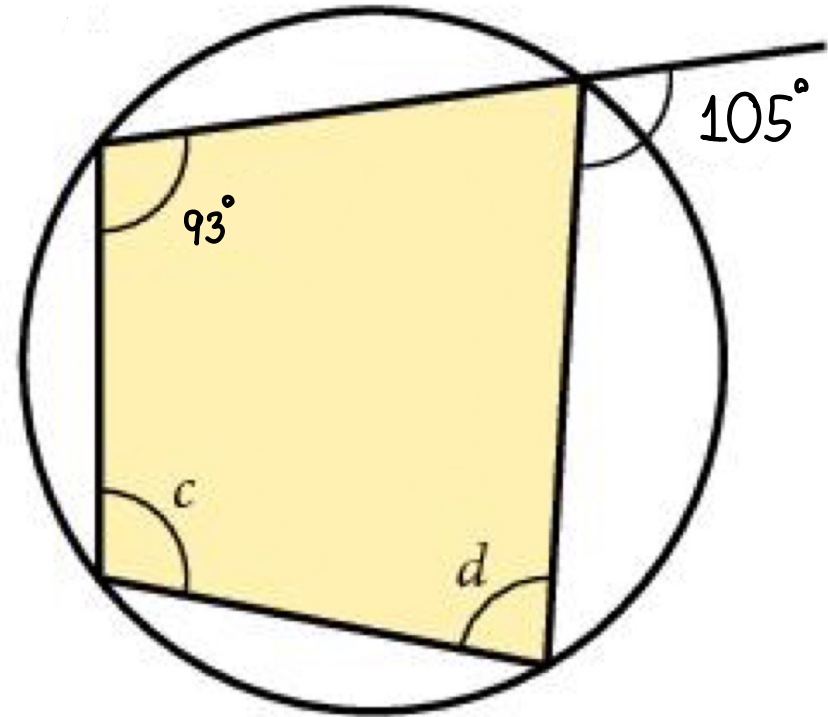
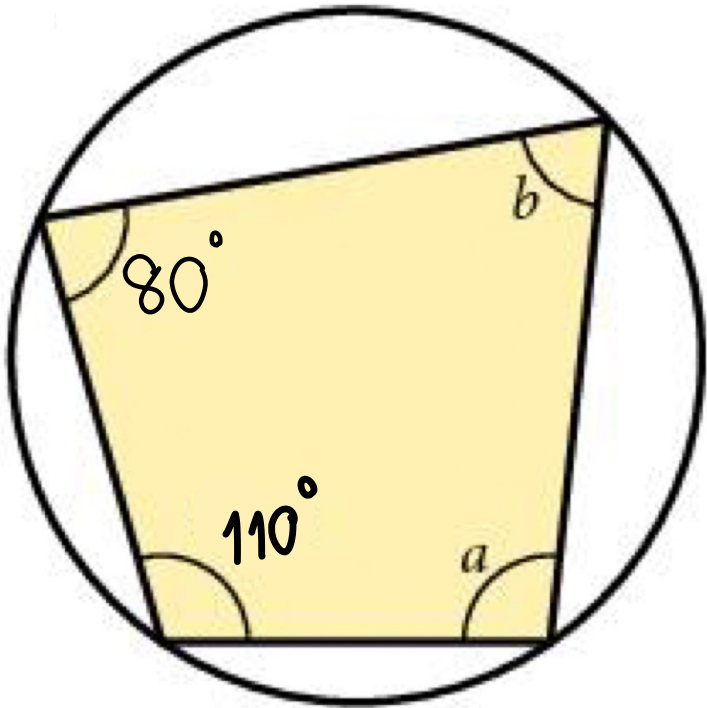

## 6. Angle between radius and tangent is $90^\circ$

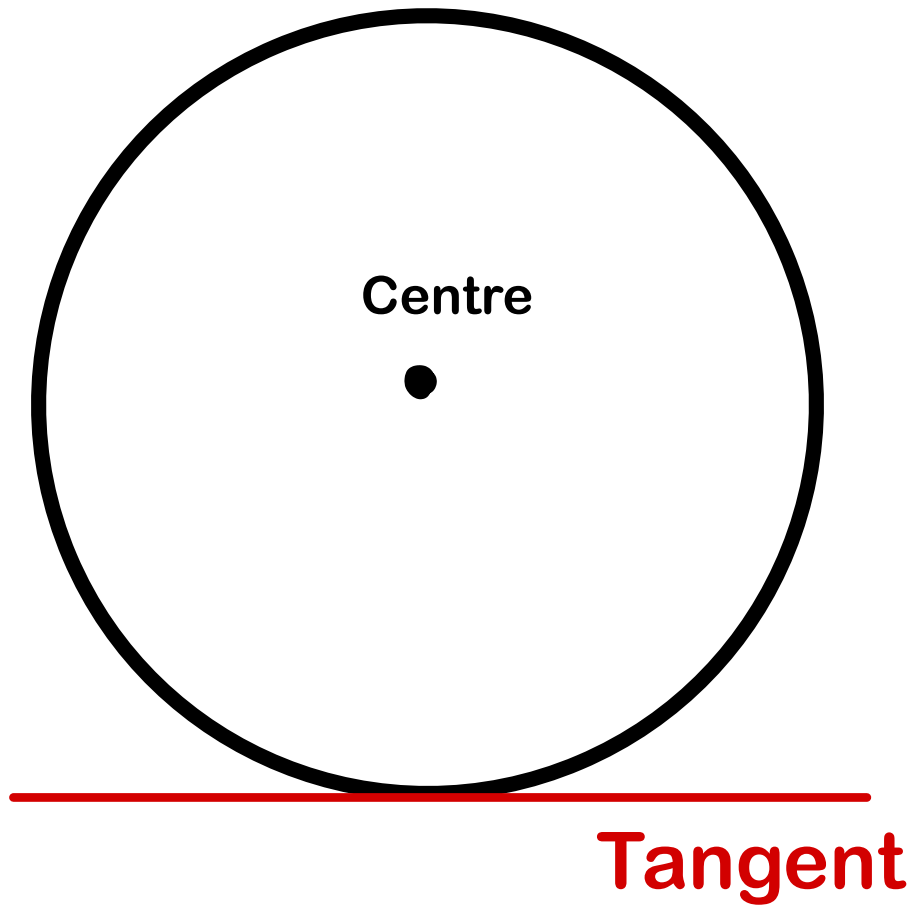

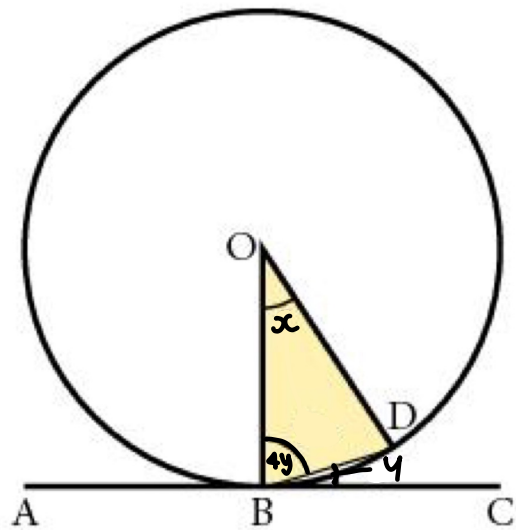
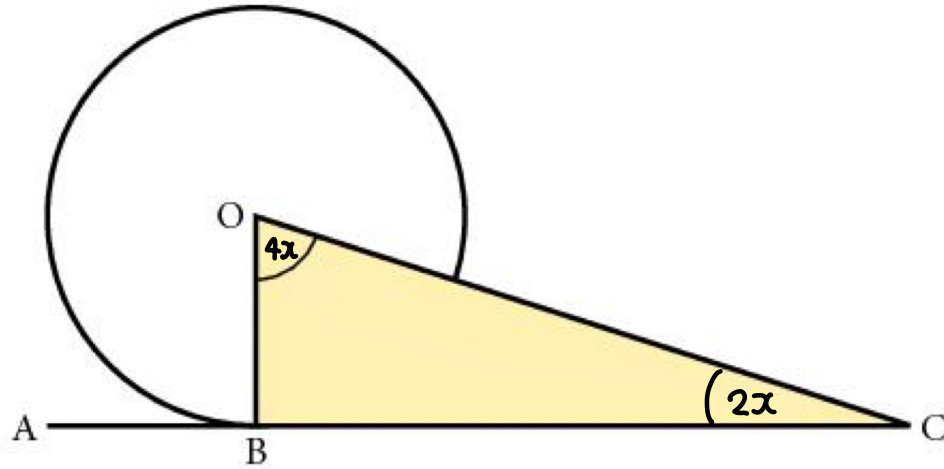

7. The tangents from the point outside circle are equal in length

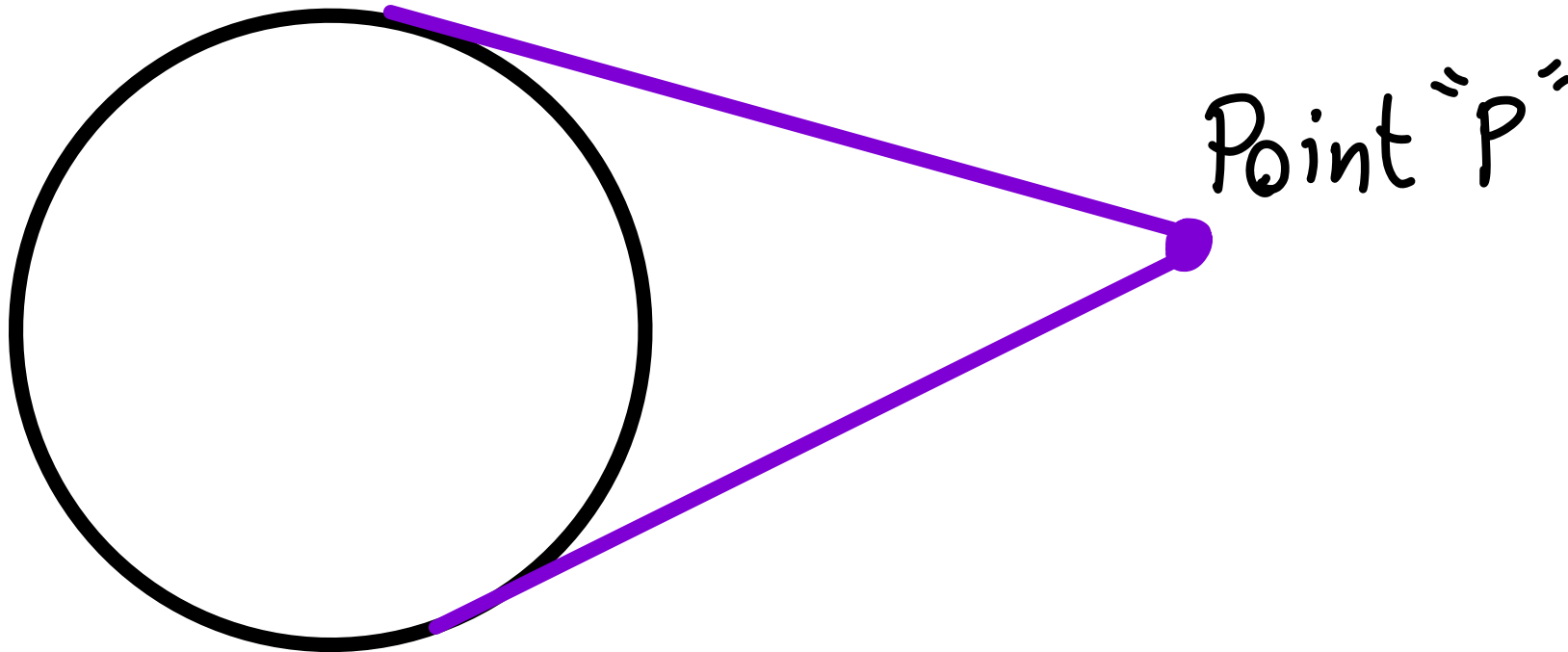

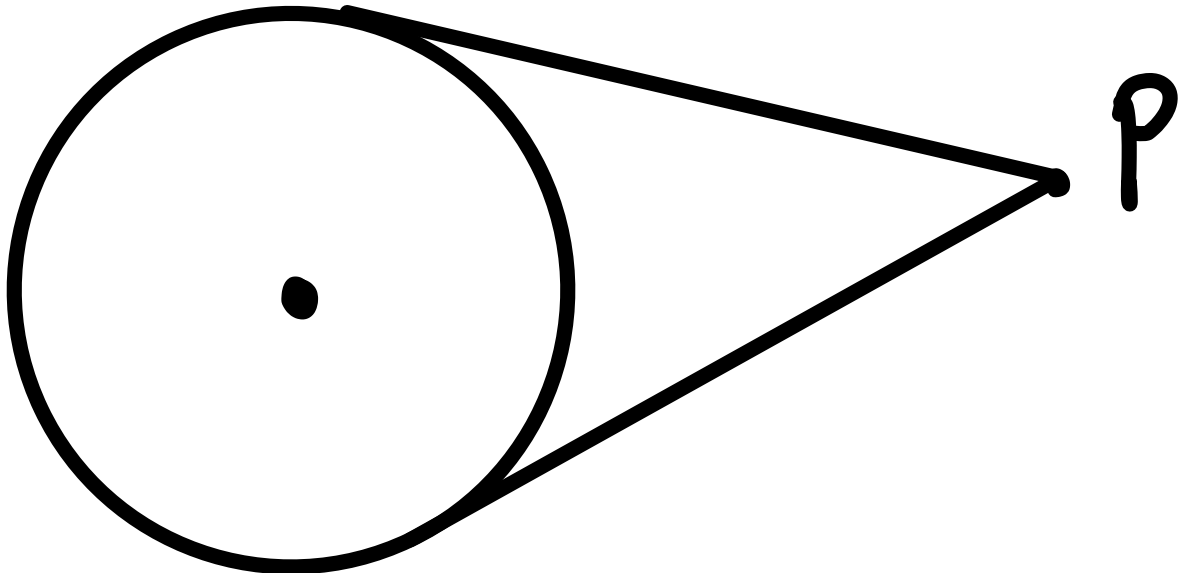
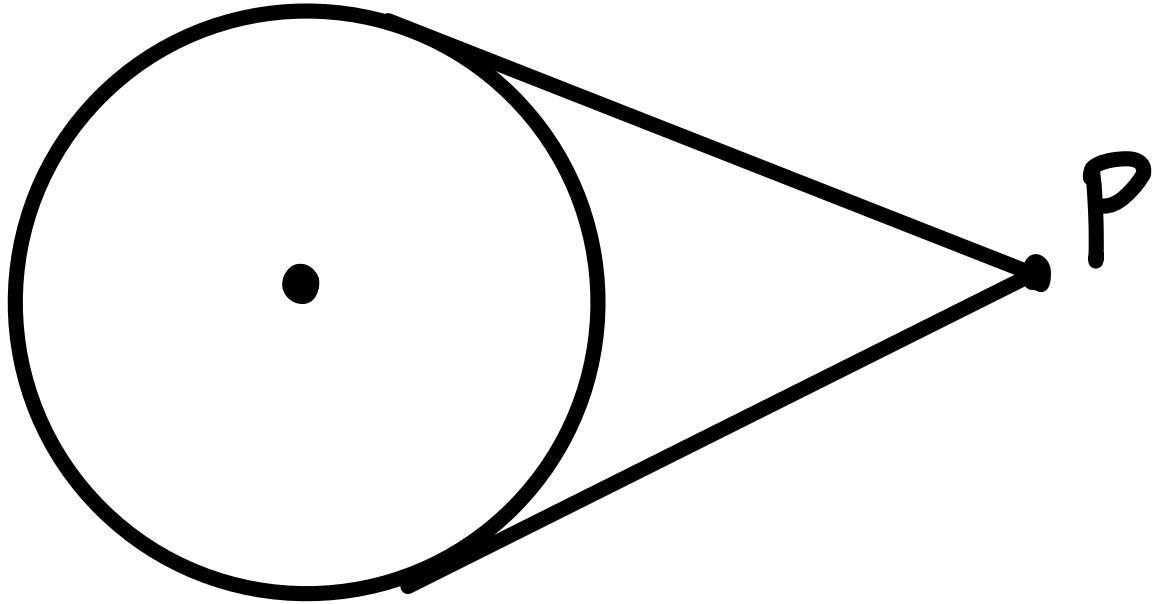

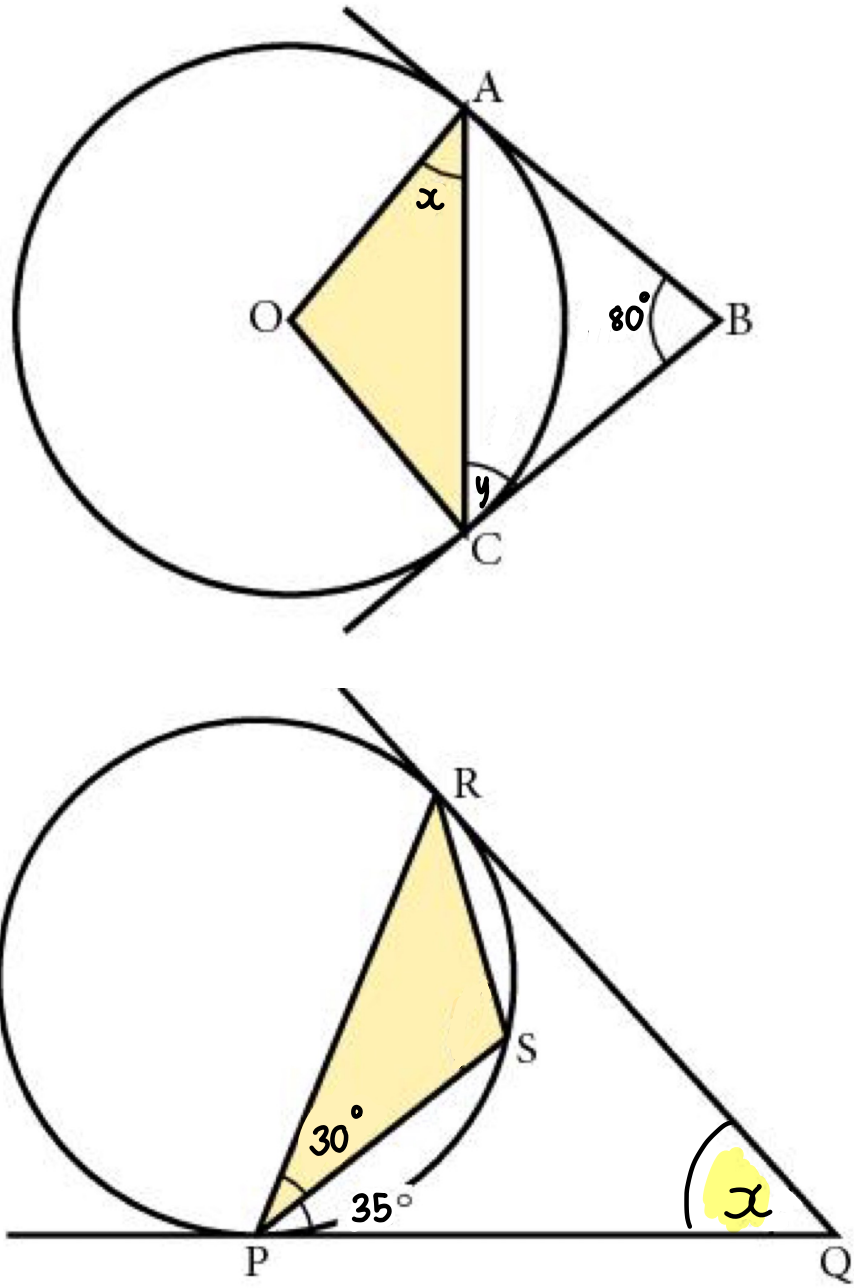

## 8. Alternate segment theorem

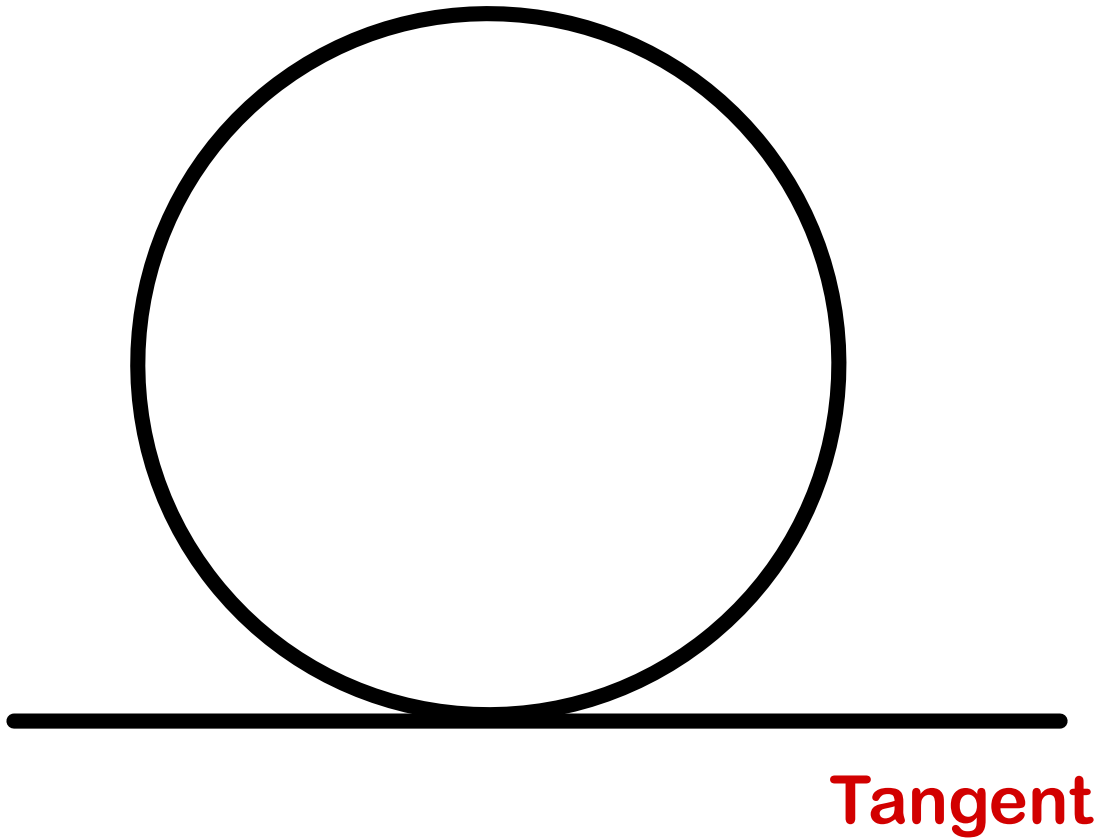

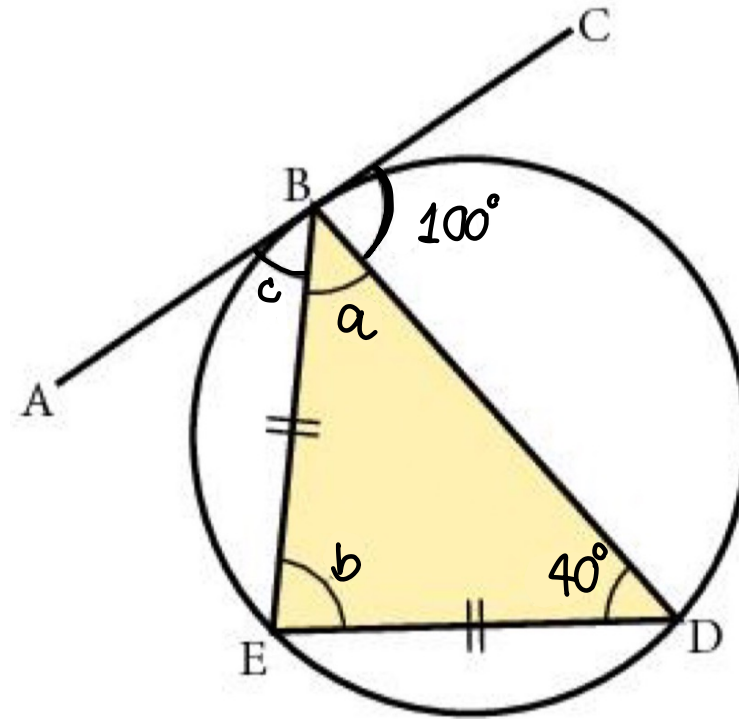
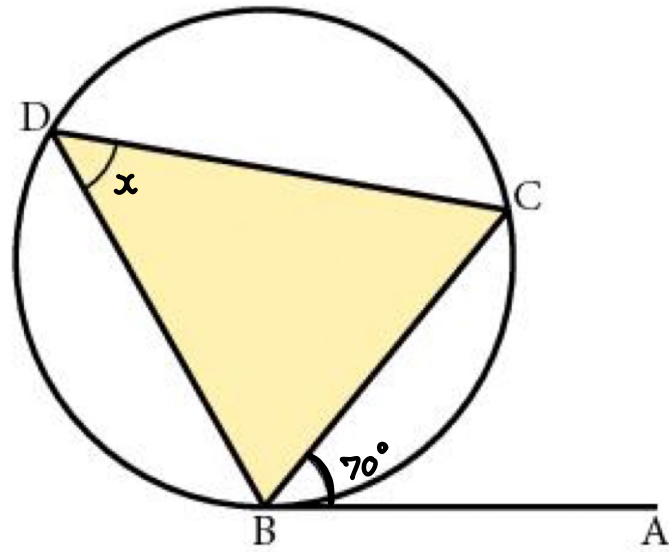

8.

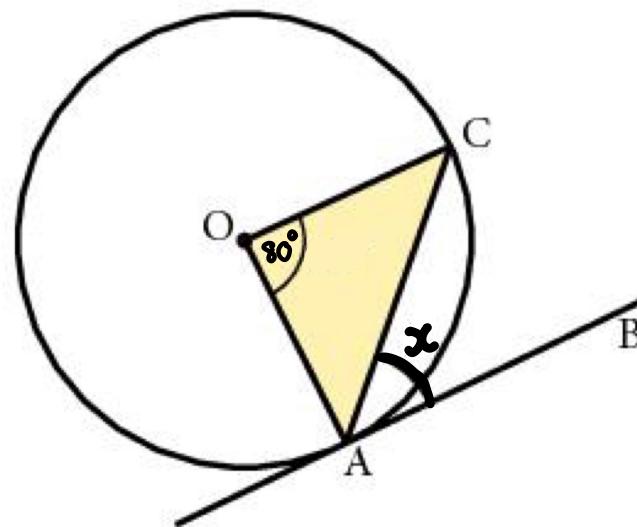

## 9. A perpendicular line from centre to the chord will bisect chord

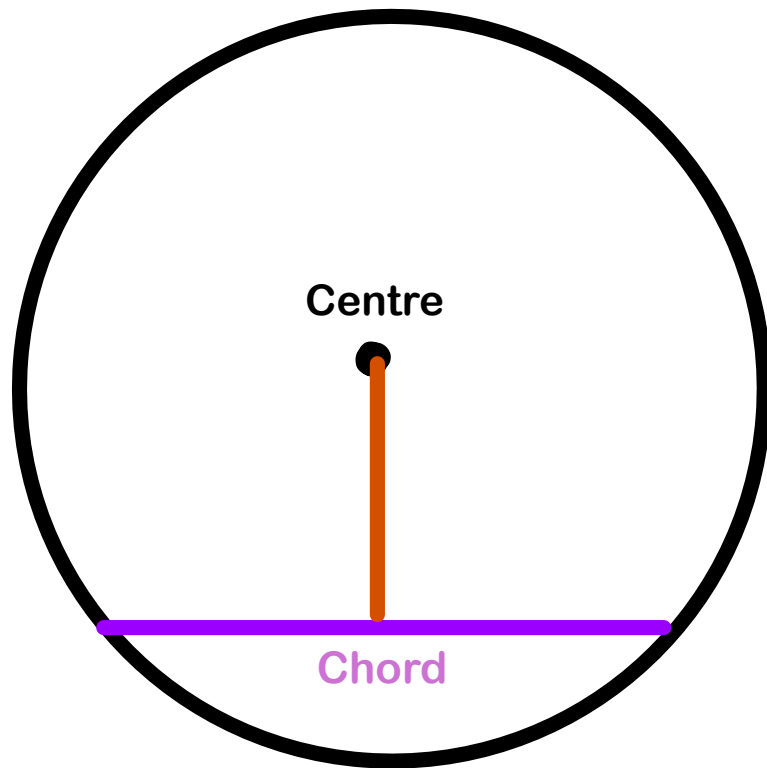

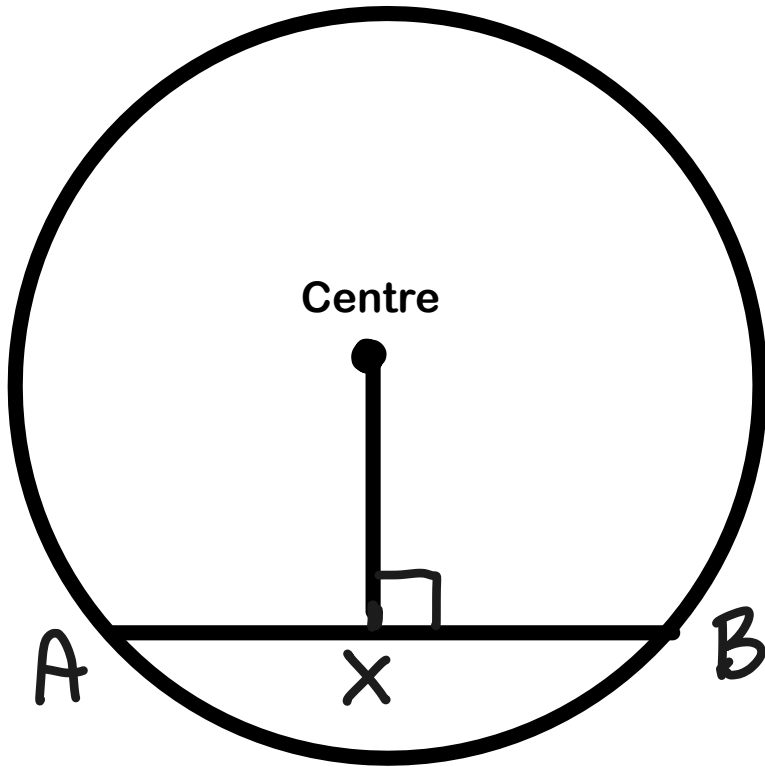

Find length of AX if AB is 10 cm

# 10. Equal chords of a circle are from the centre

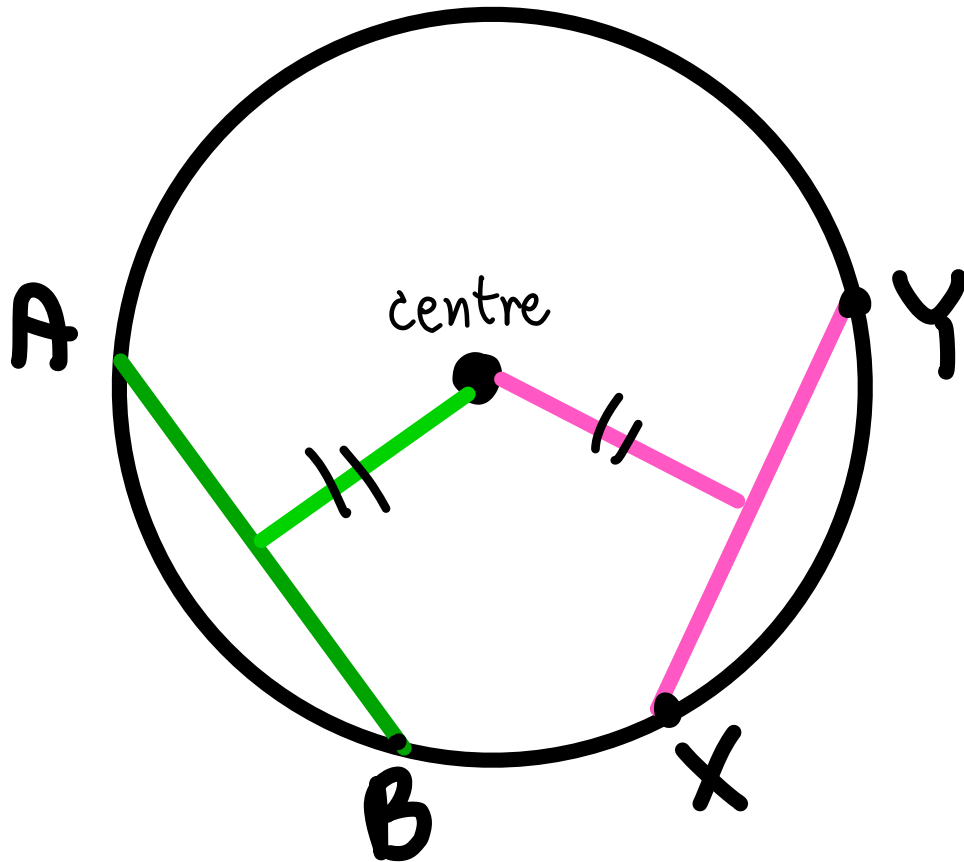

Q1.

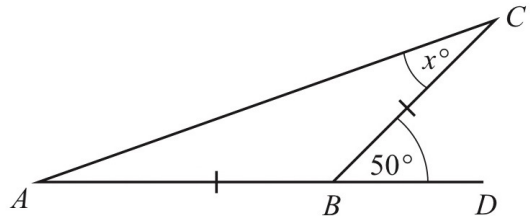

NOT TO  
SCALE

$AB = BC$  and  $ABD$  is a straight line.

Find the value of  $x$ .

Q2.

$x = \dots\dots\dots$  [2]

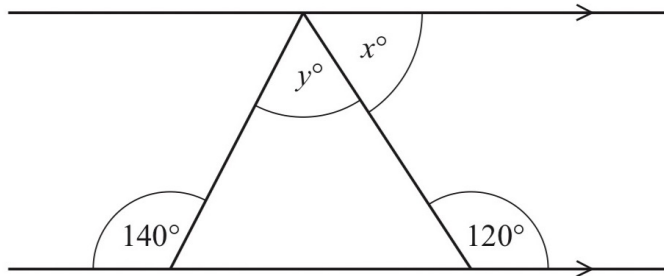

NOT TO  
SCALE

The diagram shows a triangle drawn between a pair of parallel lines.

Find the value of  $x$  and the value of  $y$ .

$x = \dots\dots\dots$

$y = \dots\dots\dots$  [3]

Q3.

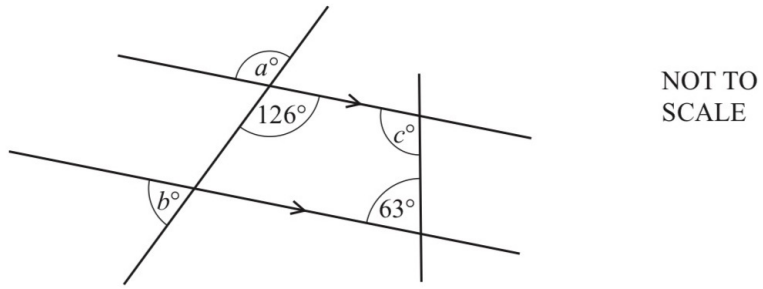

The diagram shows two straight lines intersecting two parallel lines.

Find the values of  $a$ ,  $b$  and  $c$ .

$a =$  .....

$b =$  .....

$c =$  ..... [3]

Q4.

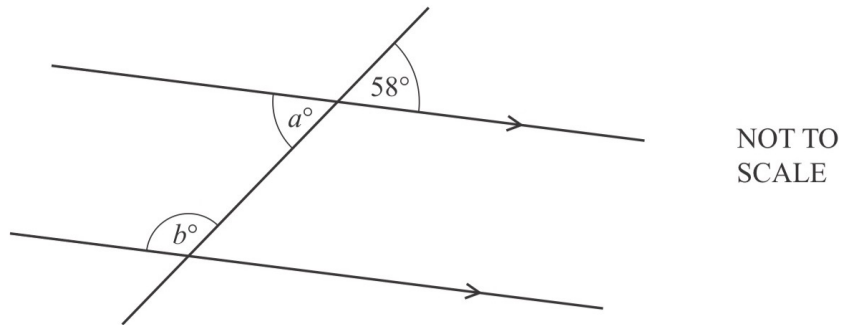

The diagram shows a straight line intersecting two parallel lines.

Find the value of  $a$  and the value of  $b$ , giving a geometrical reason for each answer.

$a =$  ..... because .....

$b =$  ..... because ..... [4]

Q5. A regular 12-sided polygon has side length 6 cm.

Show that one interior angle of the polygon is  $150^\circ$ .

[1]

Q6. The interior angle of a regular polygon is  $156^\circ$ .

Calculate the number of sides of this polygon.

..... [2]

Q7. A regular pentagon has an exterior angle,  $d$ .  
A regular hexagon has an interior angle,  $h$ .

Find the fraction  $\frac{d}{h}$ .

Give your answer in its simplest form.

..... [4]

Q8.

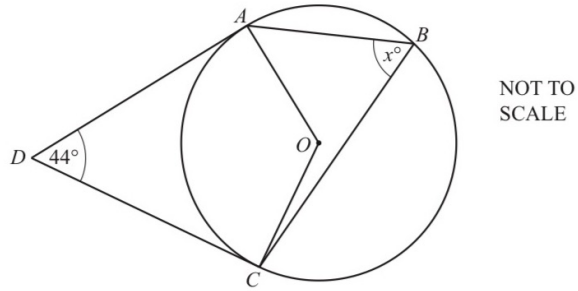

$A, B$  and  $C$  are points on a circle, centre  $O$ .  
 $DA$  and  $DC$  are tangents.  
 Angle  $ADC = 44^\circ$ .

Work out the value of  $x$ .

$x = \dots\dots\dots$  [3]

Q9.

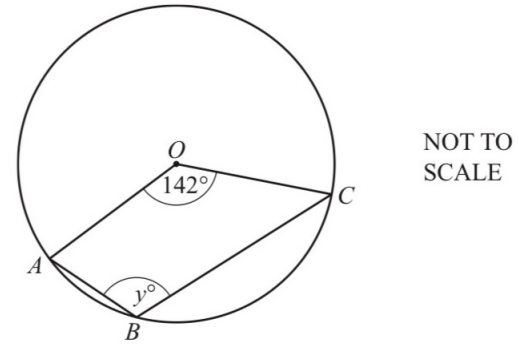

Points  $A, B$  and  $C$  lie on a circle, centre  $O$ .  
 Angle  $AOC = 142^\circ$ .

Find the value of  $y$ .

$y = \dots\dots\dots$  [2]

Q10.

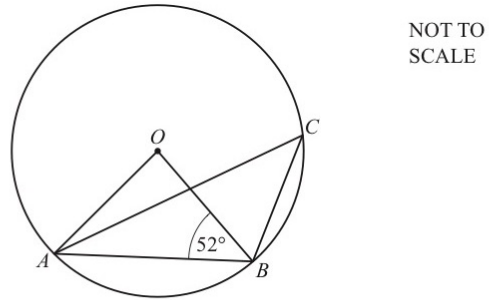

$A, B$  and  $C$  lie on a circle, centre  $O$ .  
 Angle  $OBA = 52^\circ$ .

Calculate angle  $ACB$ .

Angle  $ACB = \dots\dots\dots$  [2]

Q11.

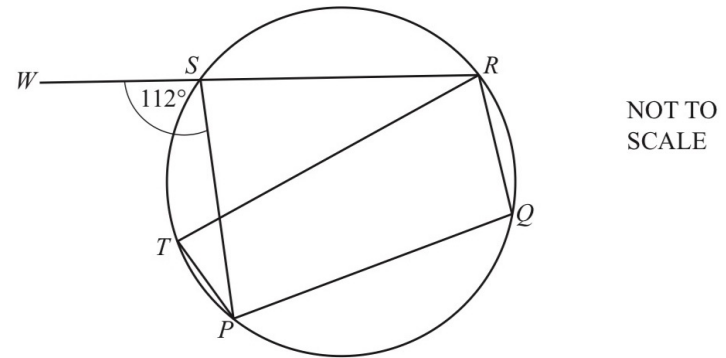

$P, Q, R, S$  and  $T$  lie on a circle.  
 $WSR$  is a straight line and angle  $WSP = 112^\circ$ .

Calculate angle  $PTR$ .

Angle  $PTR = \dots\dots\dots$  [2]

Q12.

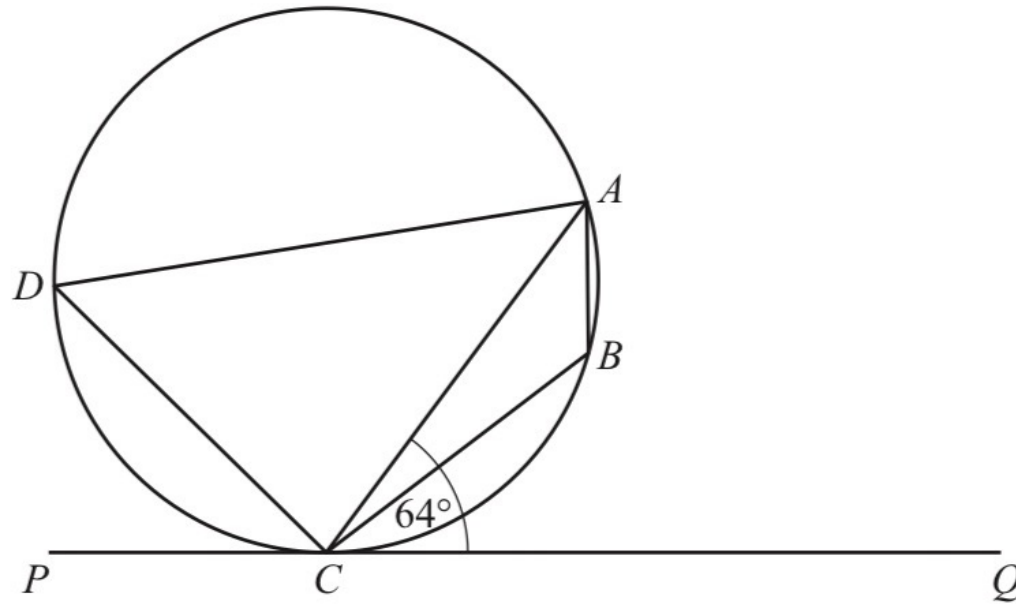

NOT TO  
SCALE

$A$ ,  $B$ ,  $C$  and  $D$  lie on the circle.  
 $PCQ$  is a tangent to the circle at  $C$ .  
Angle  $ACQ = 64^\circ$ .

Work out angle  $ABC$ , giving reasons for your answer.

Angle  $ABC = \dots\dots\dots$  because  $\dots\dots\dots$

$\dots\dots\dots$

$\dots\dots\dots$  [3]

Q13.

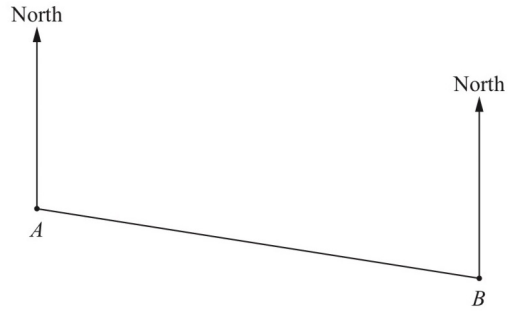

NOT TO SCALE

The bearing of  $B$  from  $A$  is  $105^\circ$ .

Find the bearing of  $A$  from  $B$ .

..... [2]

Q15.

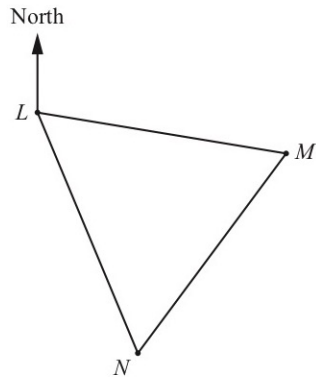

NOT TO SCALE

On a map, the positions of the towns  $L$ ,  $M$  and  $N$  form an equilateral triangle. The bearing of  $M$  from  $L$  is  $103^\circ$ .

Work out the bearing of  $L$  from  $N$ .

..... [2]

Q14.

The bearing of  $B$  from  $A$  is  $x^\circ$ .  
The bearing of  $A$  from  $B$  is  $y^\circ$ .  
 $x : y = 2 : 7$

Calculate the value of  $y$ .

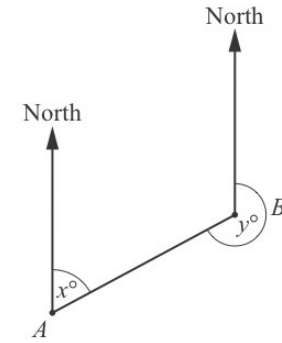

NOT TO SCALE

$y =$  ..... [3]

Q16.

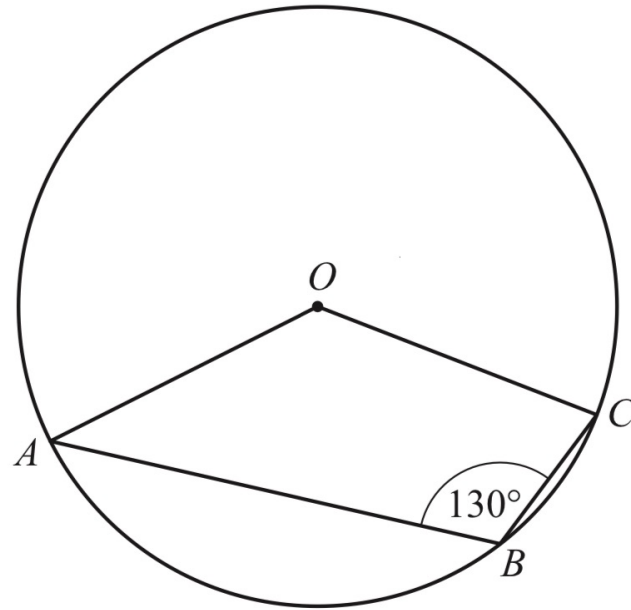

NOT TO  
SCALE

$A$ ,  $B$  and  $C$  are points on the circle, centre  $O$ .

Find the obtuse angle  $AOC$ .

Angle  $AOC$  = ..... [2]

Q17.

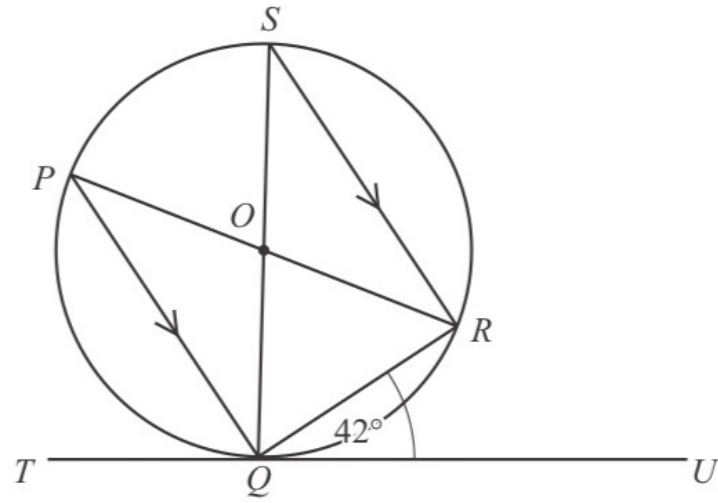

NOT TO  
SCALE

$P$ ,  $Q$ ,  $R$  and  $S$  are points on the circle and  $TQU$  is a tangent to the circle at  $Q$ .  
 $PR$  and  $SQ$  intersect at the centre of the circle,  $O$ , and  $PQ$  is parallel to  $SR$ .  
Angle  $RQU = 42^\circ$ .

Calculate

(i) angle  $QSR$

Angle  $QSR = \dots\dots\dots$  [1]

(ii) angle  $PQS$

Angle  $PQS = \dots\dots\dots$  [1]

(iii) angle  $POS$ .

Angle  $POS = \dots\dots\dots$  [1]

Q18.

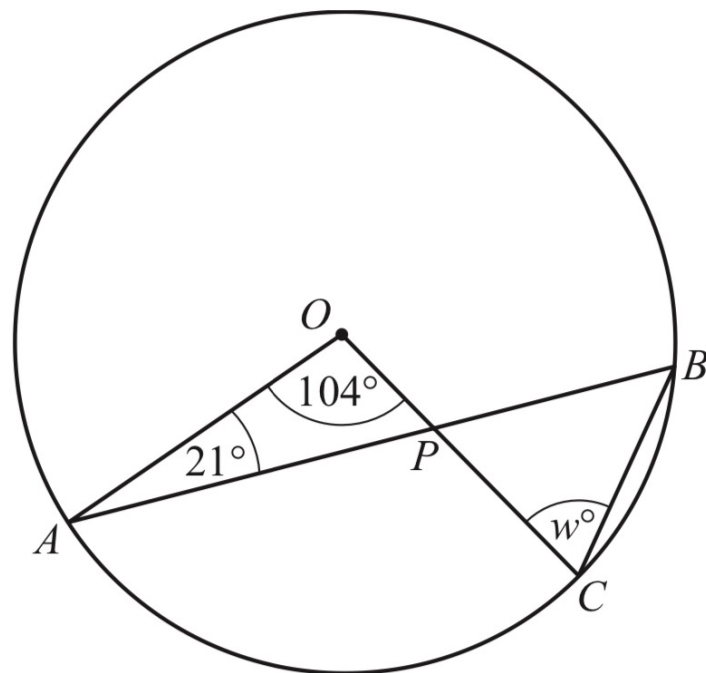

NOT TO  
SCALE

$A$ ,  $B$  and  $C$  are points on the circle, centre  $O$ .  
 $AB$  and  $OC$  intersect at  $P$ .

Find the value of  $w$ .

$w = \dots\dots\dots [3]$

Q19.

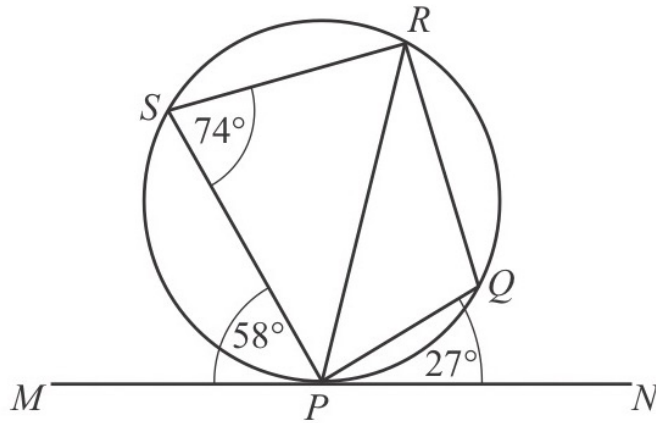

NOT TO  
SCALE

$P$ ,  $Q$ ,  $R$  and  $S$  lie on a circle.  
 $MPN$  is a tangent to the circle at  $P$ .  
Angle  $MPS = 58^\circ$ , angle  $PSR = 74^\circ$  and angle  $QPN = 27^\circ$ .

(i) Find angle  $PRS$ .

Angle  $PRS = \dots\dots\dots$  [1]

(ii) Find angle  $PQR$ .

Angle  $PQR = \dots\dots\dots$  [1]

(iii) Find angle  $RPQ$ .

Angle  $RPQ = \dots\dots\dots$  [2]

Q20.

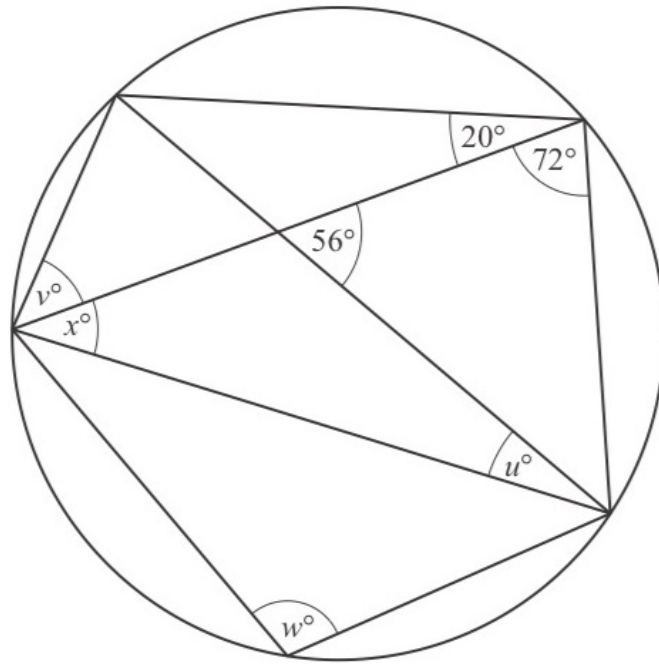

NOT TO  
SCALE

The diagram shows a circle and eight chords.

Calculate the values of  $u$ ,  $v$ ,  $w$  and  $x$ .

$u = \dots\dots\dots$

$v = \dots\dots\dots$

$w = \dots\dots\dots$

$x = \dots\dots\dots [4]$

Q21.

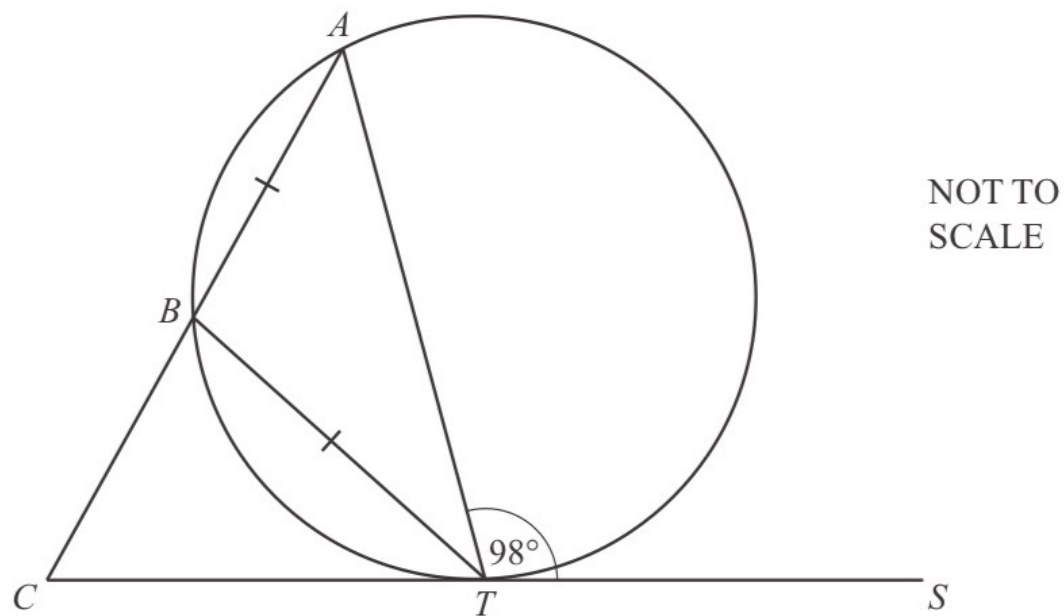

The points  $A$ ,  $B$  and  $T$  lie on a circle and  $CTS$  is a tangent to the circle at  $T$ .  
 $ABC$  is a straight line and  $AB = BT$ .  
Angle  $ATS = 98^\circ$ .

Work out the size of angle  $ACT$ .

Angle  $ACT = \dots\dots\dots$  [4]

Q22.

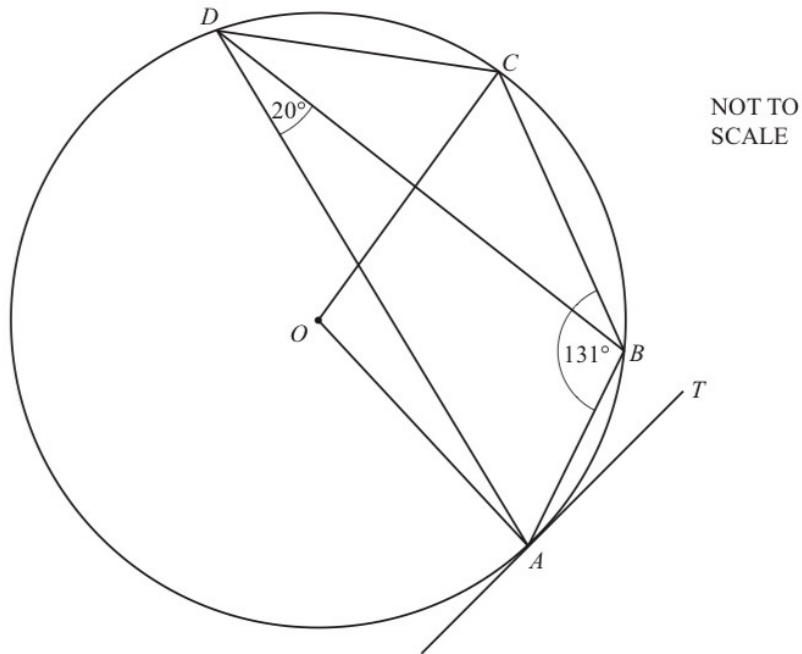

$A, B, C$  and  $D$  lie on the circle, centre  $O$ .  
 $TA$  is a tangent to the circle at  $A$ .  
 Angle  $ABC = 131^\circ$  and angle  $ADB = 20^\circ$ .

Find

(a) angle  $ADC$ ,

Angle  $ADC = \dots\dots\dots$  [1]

(b) angle  $AOC$ ,

Angle  $AOC = \dots\dots\dots$  [1]

(c) angle  $BAT$ ,

Angle  $BAT = \dots\dots\dots$  [1]

(d) angle  $OAB$ .

Angle  $OAB = \dots\dots\dots$  [1]

Q23.

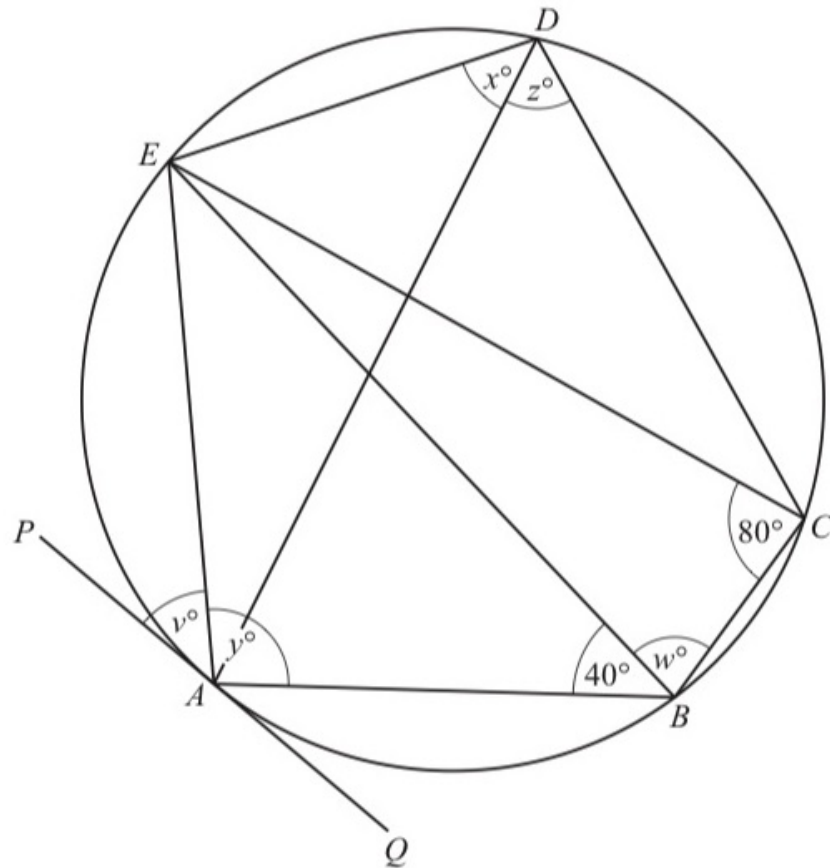

NOT TO  
SCALE

The points  $A, B, C, D$  and  $E$  lie on the circle.  
 $PAQ$  is a tangent to the circle at  $A$  and  $EC = EB$ .  
 Angle  $ECB = 80^\circ$  and angle  $ABE = 40^\circ$ .

Find the values of  $v, w, x, y$  and  $z$ .

$v = \dots\dots\dots$      $w = \dots\dots\dots$      $x = \dots\dots\dots$      $y = \dots\dots\dots$      $z = \dots\dots\dots$  [5]

Q24.

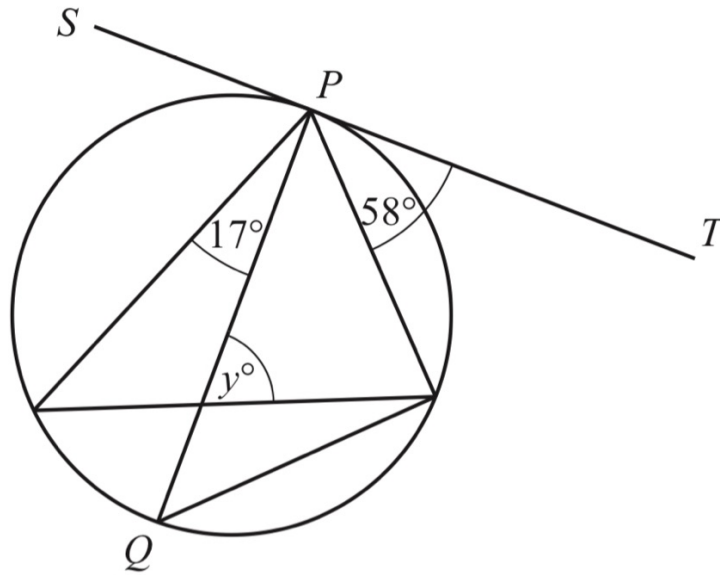

NOT TO  
SCALE

The diagram shows a circle with diameter  $PQ$ .  
 $SPT$  is a tangent to the circle at  $P$ .

Find the value of  $y$ .

$y = \dots\dots\dots$  [5]

Q25.

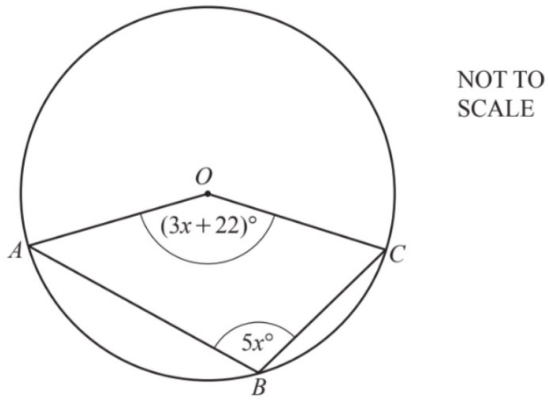

$A$ ,  $B$  and  $C$  lie on the circle, centre  $O$ .  
Angle  $AOC = (3x + 22)^\circ$  and angle  $ABC = 5x^\circ$ .

Find the value of  $x$ .

Q26.

$x = \dots\dots\dots$  [4]

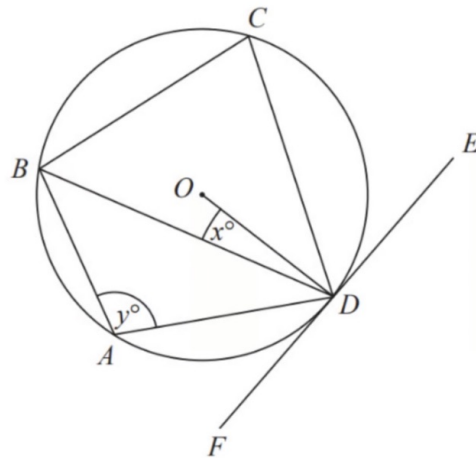

$A$ ,  $B$ ,  $C$  and  $D$  are points on the circumference of a circle, centre  $O$ .  
 $FDE$  is a tangent to the circle.

Show that  $y - x = 90$

You must give a reason for each stage of your working.

[3]

Q27.

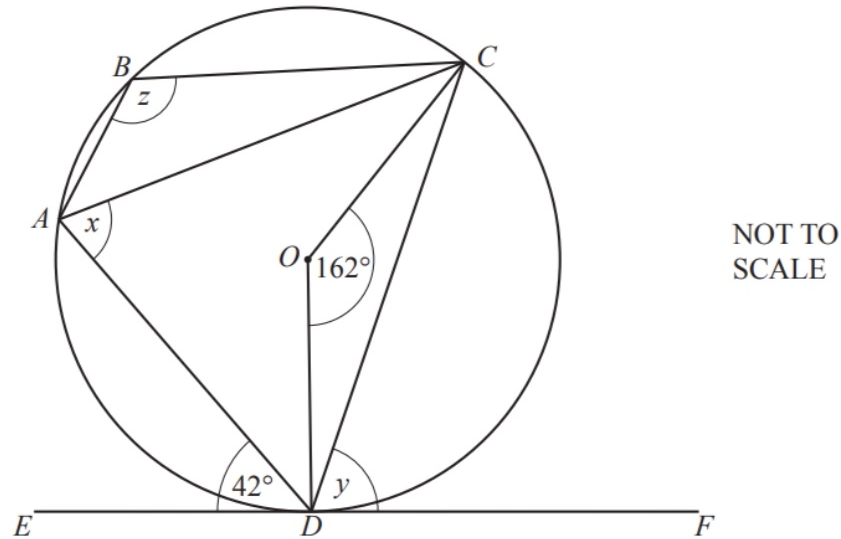

NOT TO SCALE

$A, B, C$  and  $D$  are points on the circle, centre  $O$ .

$EF$  is a tangent to the circle at  $D$ .

Angle  $ADE = 42^\circ$  and angle  $COD = 162^\circ$ .

Find the following angles, giving reasons for each of your answers.

i) Angle  $x$

$x = \dots\dots\dots$  because  $\dots\dots\dots$  [2]

ii) Angle  $y$

$y = \dots\dots\dots$  because  $\dots\dots\dots$  [2]

iii) Angle  $z$

$z = \dots\dots\dots$  because  $\dots\dots\dots$  [3]

Q28.

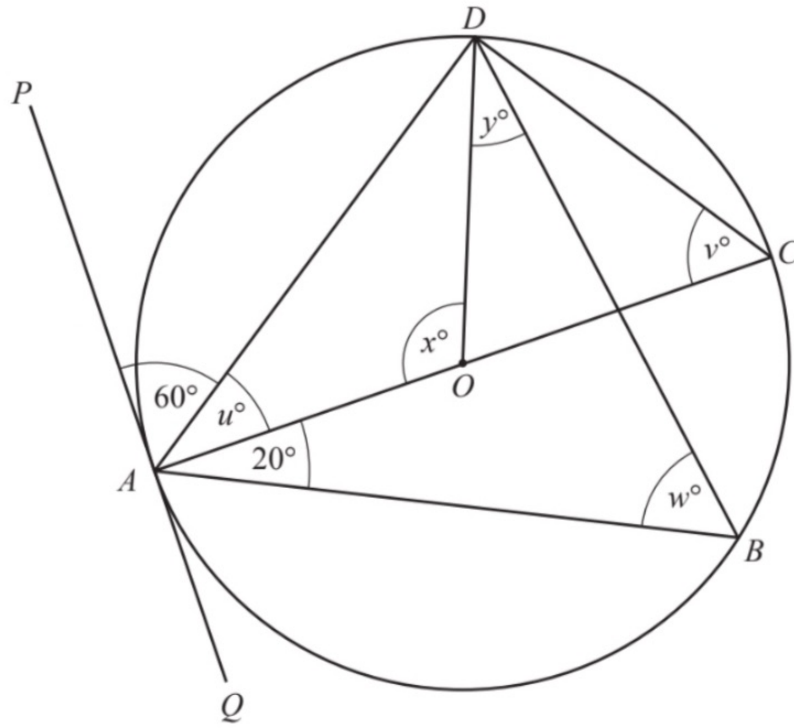

NOT TO SCALE

$A, B, C$  and  $D$  lie on the circle, centre  $O$ , with diameter  $AC$ .

$PQ$  is a tangent to the circle at  $A$ .

Angle  $PAD = 60^\circ$  and angle  $BAC = 20^\circ$ .

Find the values of  $u, v, w, x$  and  $y$ .

$u = \dots\dots\dots, v = \dots\dots\dots, w = \dots\dots\dots,$

$x = \dots\dots\dots, y = \dots\dots\dots$

[6]

Q29.

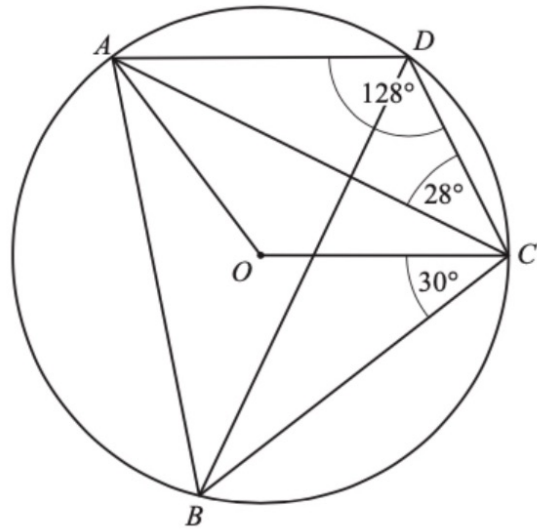

NOT TO  
SCALE

In the diagram,  $A$ ,  $B$ ,  $C$  and  $D$  lie on the circle, centre  $O$ .  
Angle  $ADC = 128^\circ$ , angle  $ACD = 28^\circ$  and angle  $BCO = 30^\circ$ .

Show that obtuse angle  $AOC = 104^\circ$ .

Give a reason for each step of your working.

[3]

Q30.

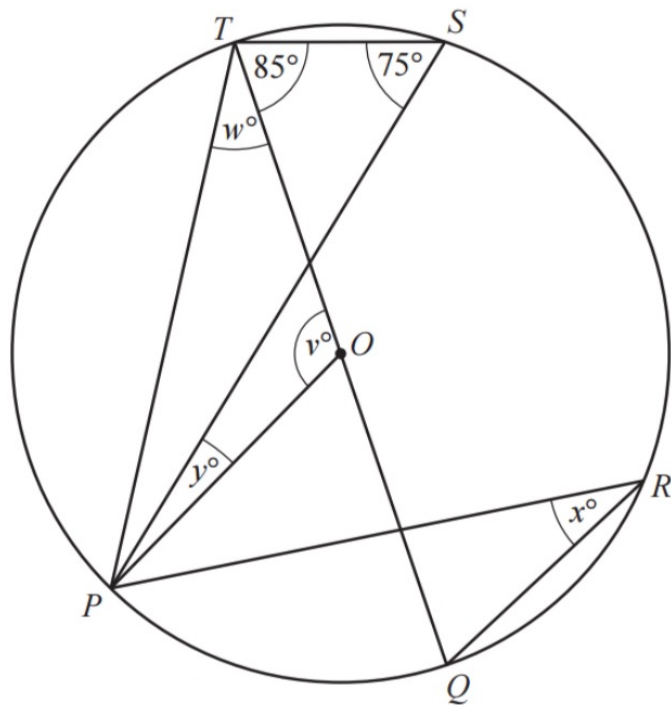

NOT TO  
SCALE

$P, Q, R, S$  and  $T$  lie on the circle, centre  $O$ .  
Angle  $PST = 75^\circ$  and angle  $QTS = 85^\circ$ .

Find the values of  $v, w, x$  and  $y$ .

$v = \dots\dots\dots$

$w = \dots\dots\dots$

$x = \dots\dots\dots$

$y = \dots\dots\dots$

[6]

# Circles and sector



By .... Kru ชี



# Parts of circle

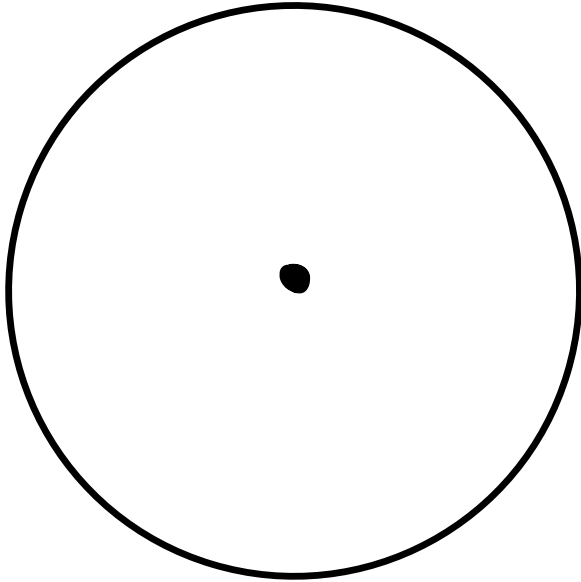

# Circumference of circle

# Arc length

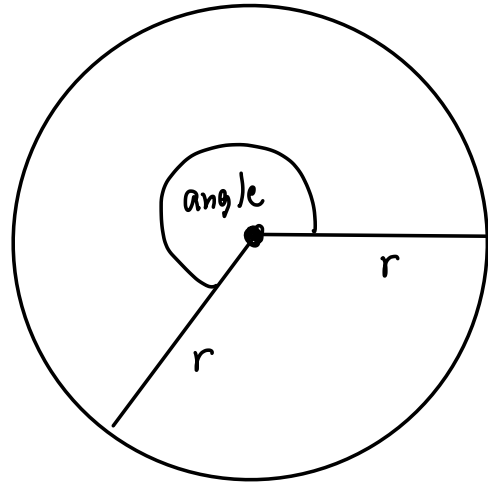
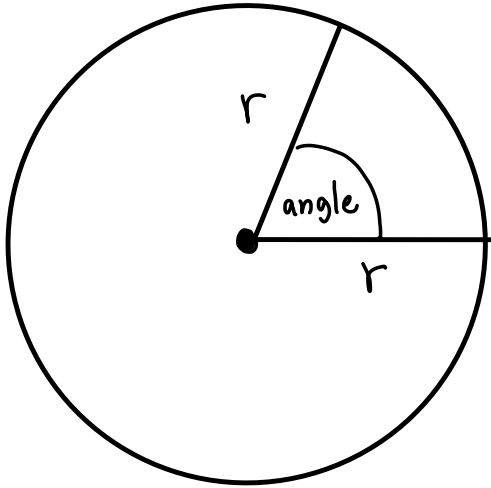

Example

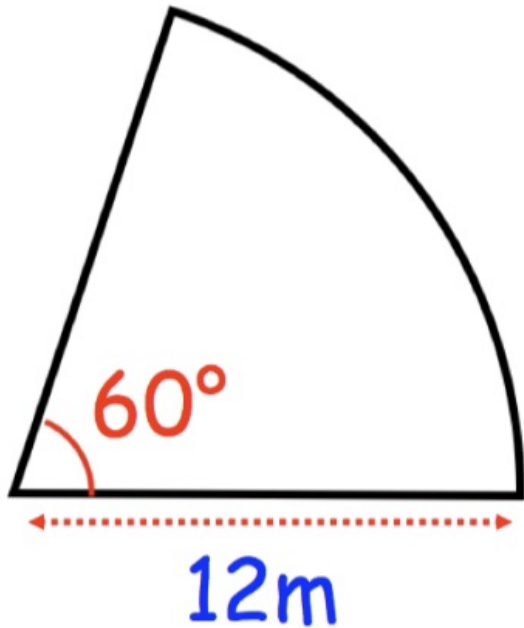

Find the arc length and perimeter

## Area of circle

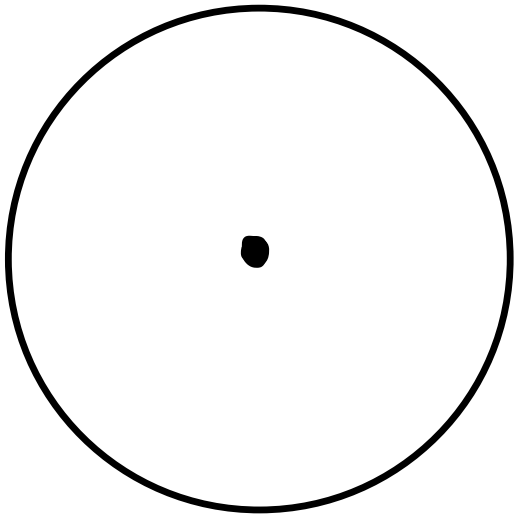

# Area of sector

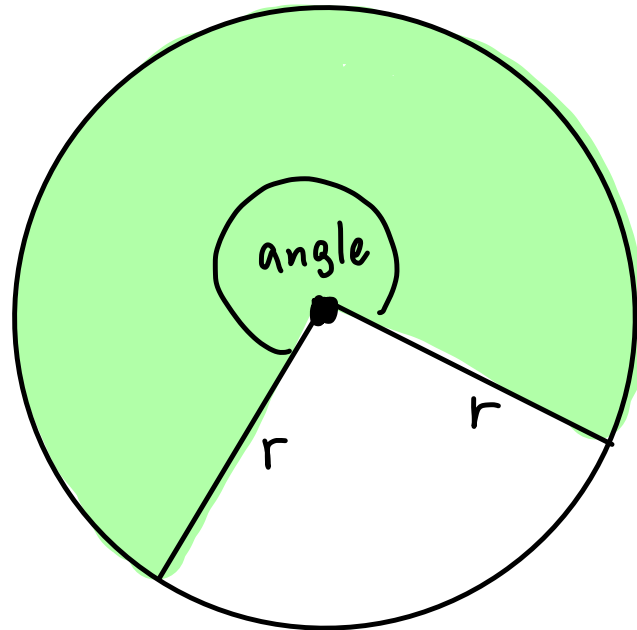
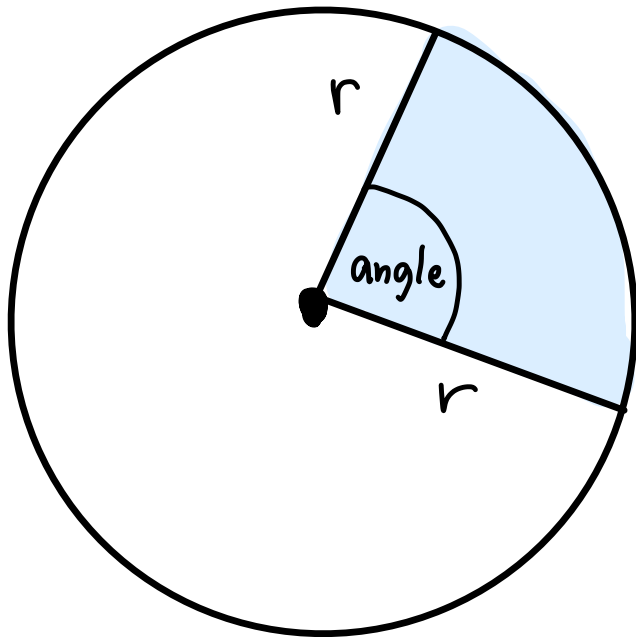

Example

Find the area

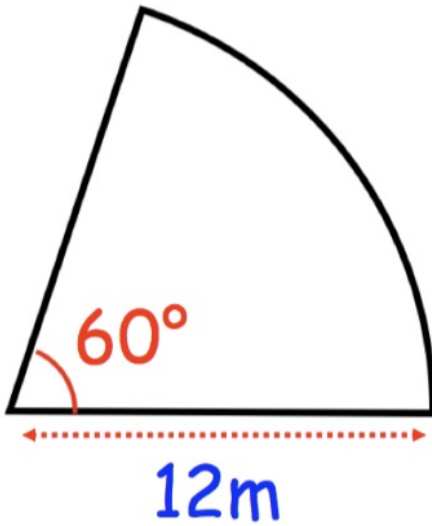

# Segment

Q1. a) Calculate the circumference of a circle with radius 4.7 cm.

..... cm [2]

b)

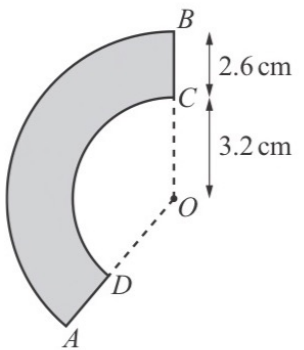

NOT TO SCALE

The diagram shows a shape,  $ABCD$ , formed by the sectors of two circles with the same centre  $O$ . Both sector angles are  $140^\circ$ ,  $OC = 3.2$  cm and  $CB = 2.6$  cm. The area of the shape is  $k\pi$  cm<sup>2</sup>.

Find the value of  $k$ .

$k =$  ..... [3]

Q2.

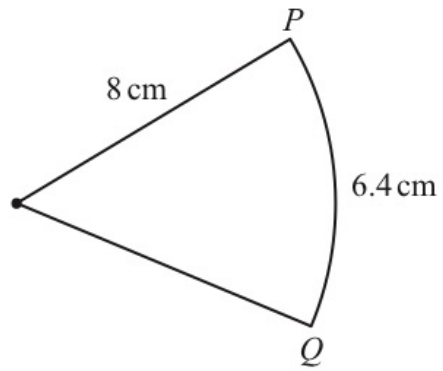

NOT TO  
SCALE

The diagram shows a sector of a circle of radius 8 cm.  
The length of the arc  $PQ$  is 6.4 cm.

Find the area of the sector.

.....  $\text{cm}^2$  [4]

Q2.

(a)

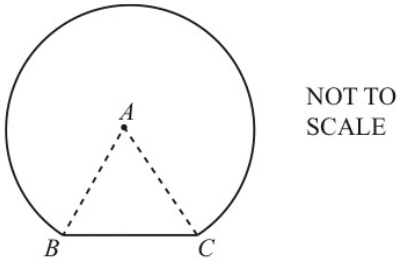

The diagram shows a shape made from an equilateral triangle  $ABC$  and a sector of a circle. Points  $B$  and  $C$  lie on the circle, centre  $A$ . The side length of the equilateral triangle is  $12.4$  cm.

Work out the perimeter of the shape.

..... cm [3]

(b)

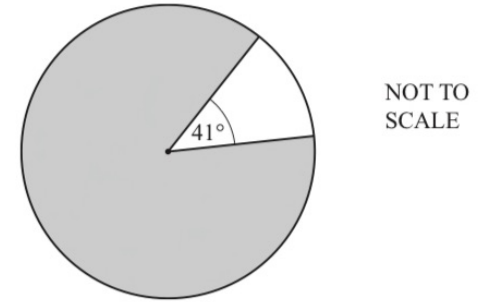

The diagram shows two sectors of a circle. The major sector is shaded. The area of the major sector is  $74.5$  cm<sup>2</sup>.

Calculate the radius of the circle.

..... cm [3]

Q4.

The polygon is enclosed by a circle, centre  $O$ , so that each vertex touches the circumference of the circle.

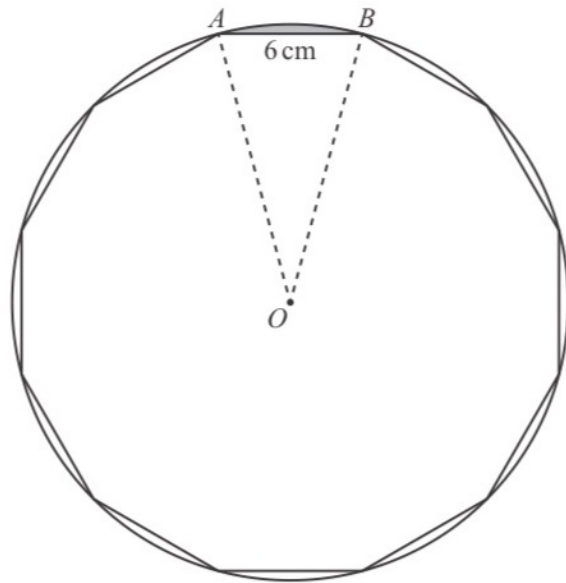

NOT TO  
SCALE

(ii) Calculate

(a) the circumference of the circle,

..... cm [2]

(b) the perimeter of the shaded **minor** segment formed by the chord  $AB$ .

..... cm [2]

(i) Show that the radius,  $AO$ , of the circle is 11.6 cm, correct to 1 decimal place.

[3]

Q5.

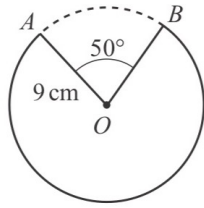

NOT TO  
SCALE

The diagram shows a circle of radius 9 cm, centre  $O$ .  
The minor sector  $AOB$ , with sector angle  $50^\circ$ , is removed from the circle.  
Calculate the length of the major arc  $AB$ .

..... cm [3]

Q6.

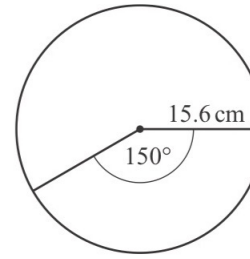

NOT TO  
SCALE

The diagram shows a circle, radius 15.6 cm.  
The angle of the minor sector is  $150^\circ$ .  
Calculate the area of the minor sector.

.....  $\text{cm}^2$  [2]

Q7.

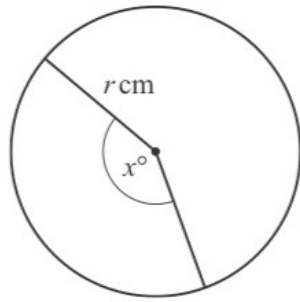

NOT TO  
SCALE

The diagram shows a circle, radius  $r \text{ cm}$  and minor sector angle  $x^\circ$ .  
The **perimeter** of the major sector is three times the **perimeter** of the minor sector.

Show that  $x = \frac{90(\pi - 2)}{\pi}$ .

[4]

Q8.

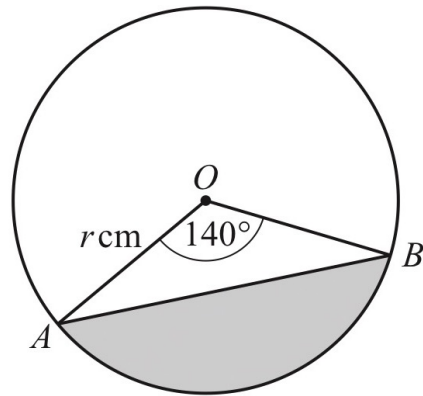

NOT TO  
SCALE

$A$  and  $B$  are points on a circle, centre  $O$ , radius  $r$  cm.  
The area of the shaded segment is  $65 \text{ cm}^2$ .

Calculate the value of  $r$ . [4]



# Mensuration

( Perimeter , area , volume )



By .... Kru ชี

 Perimeter is the total distance around the 2D shapes

## Perimeter in regular polygons

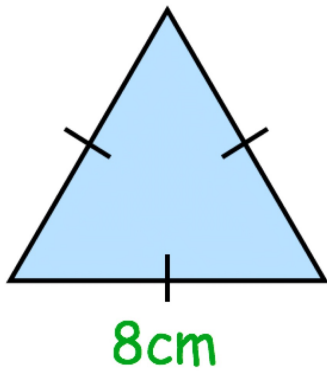

15cm

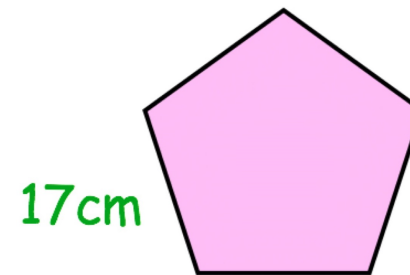
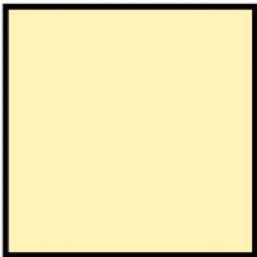

7cm

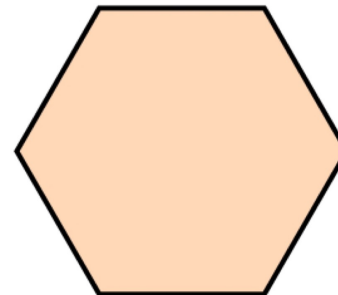

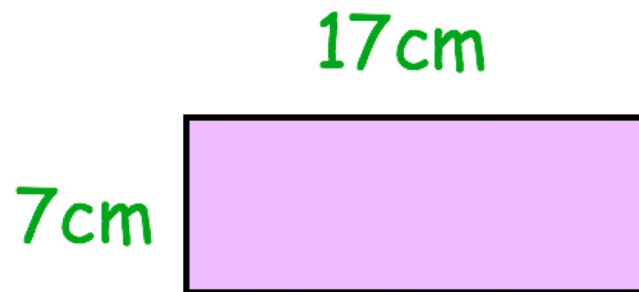
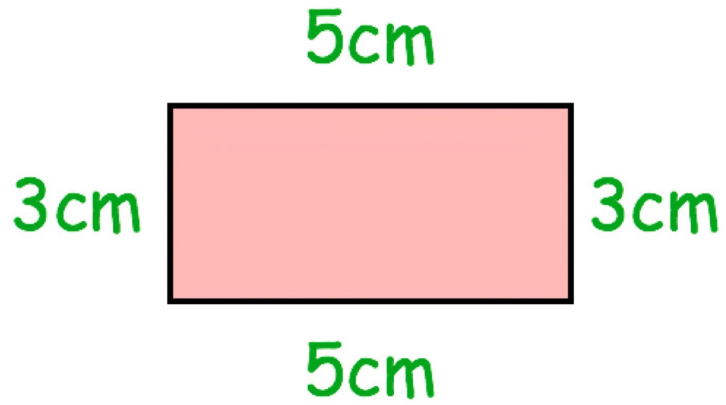

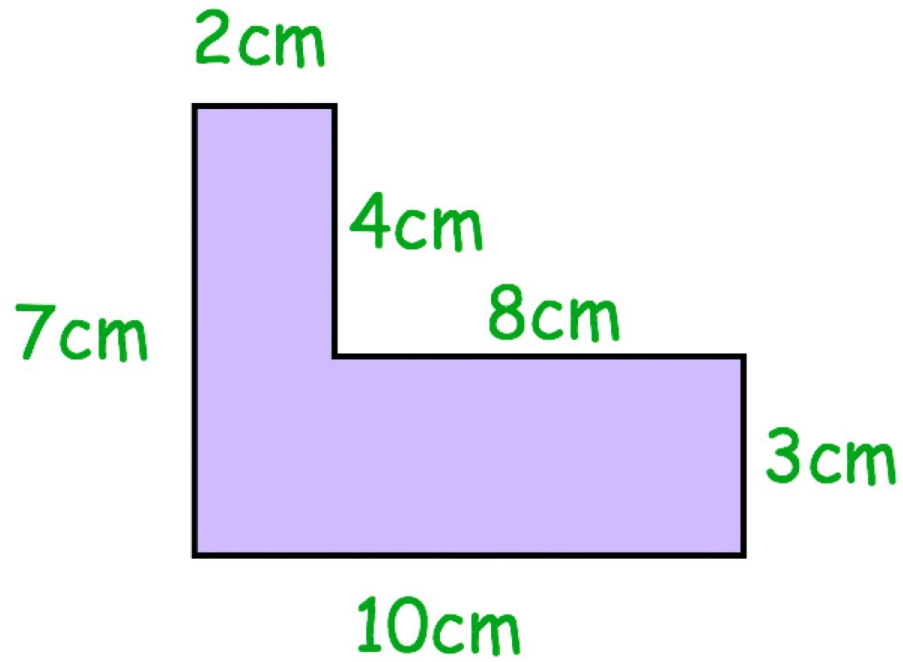

 Area is the region inside 2D shapes

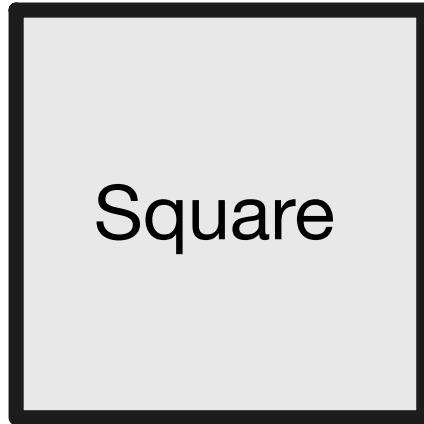



Rectangle

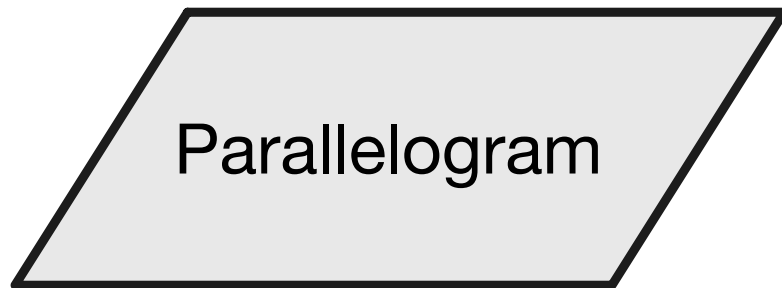

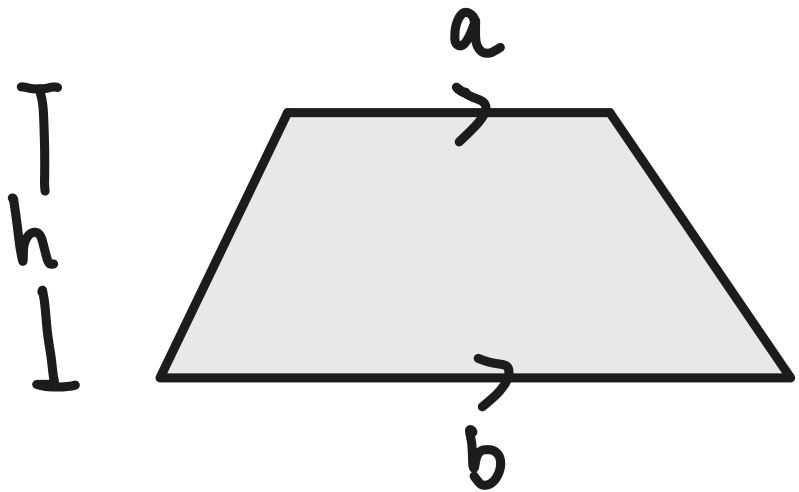

# Cube

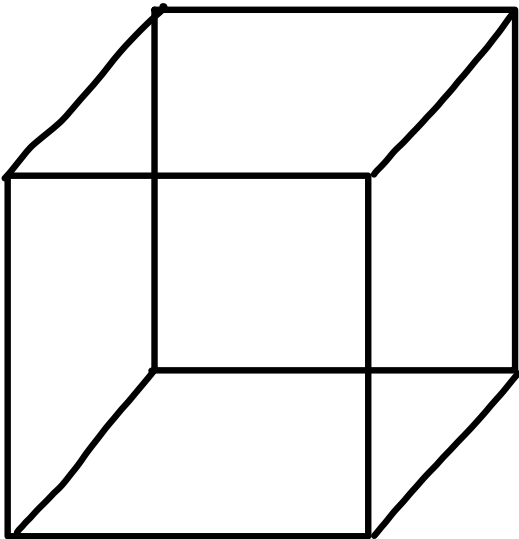

**Example**

Find the total surface area

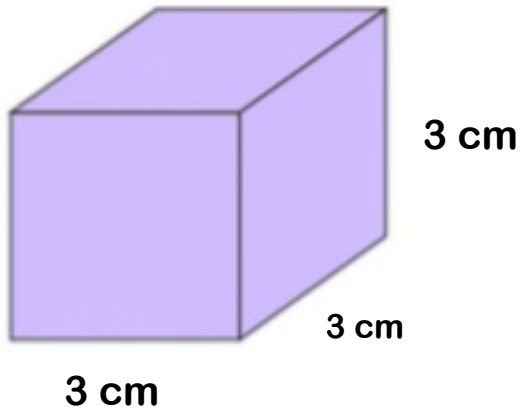

# Cuboid

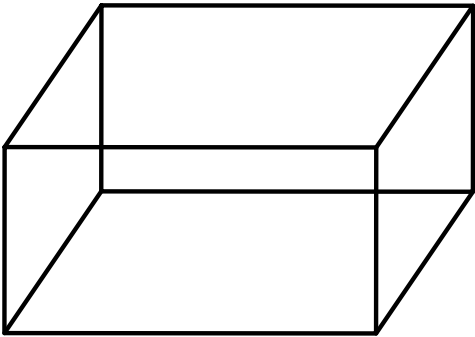

**Example**

Find the total surface area

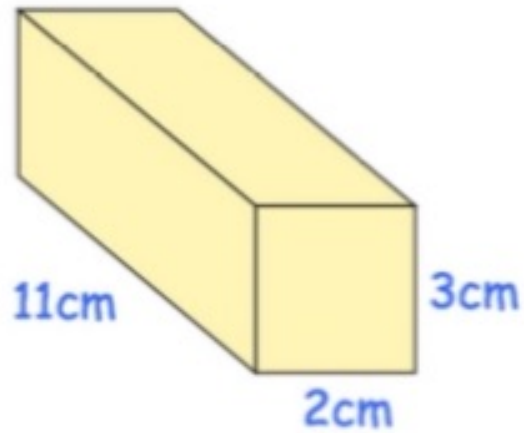

# Prisms

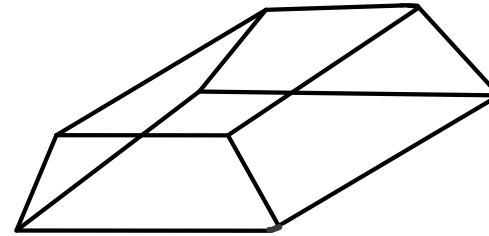
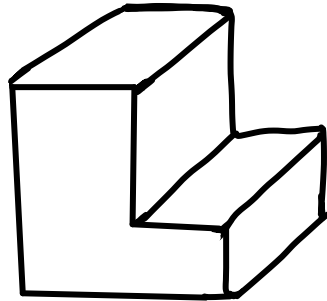
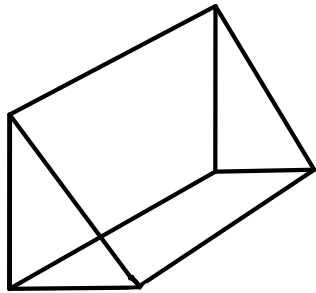

**Example**

Find the total surface area

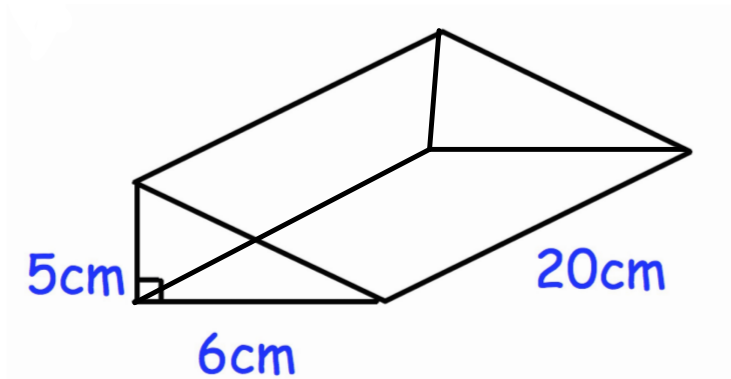

**Example**

Find the total surface area

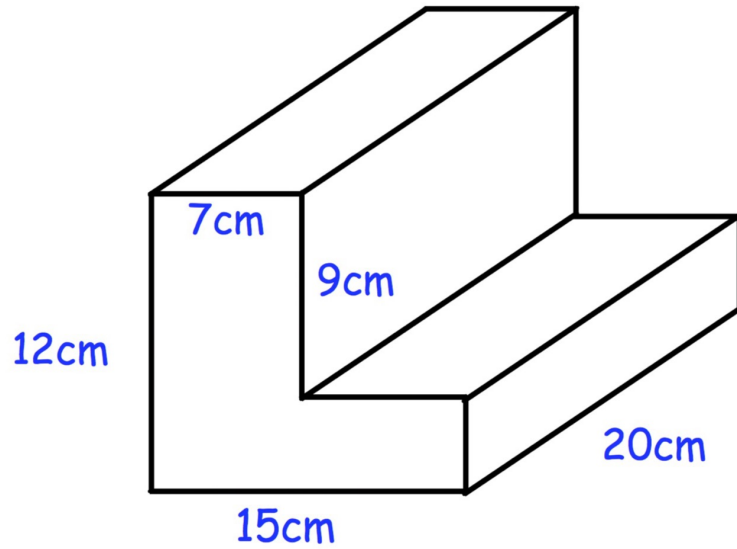

# Cylinder

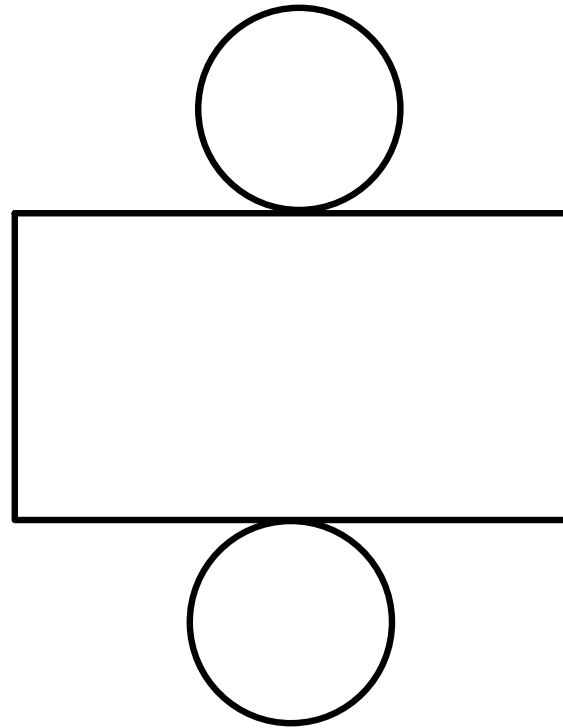
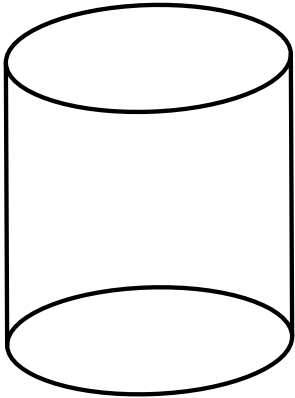

**Example**

Find the total surface area

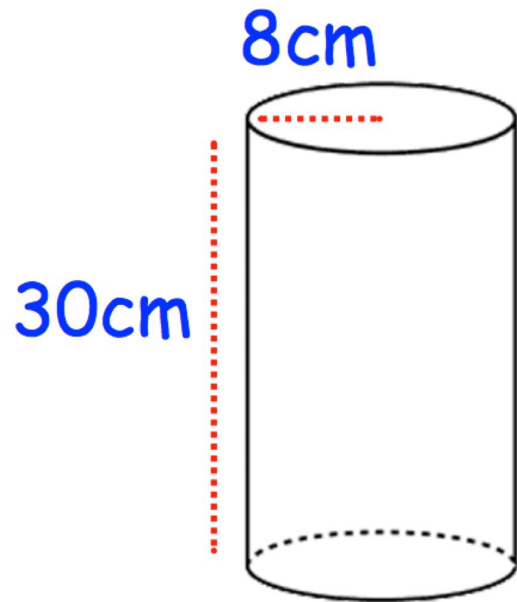

Example

Find the total surface area

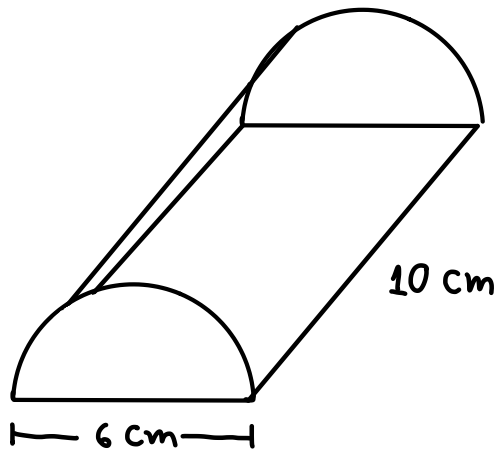

Cone

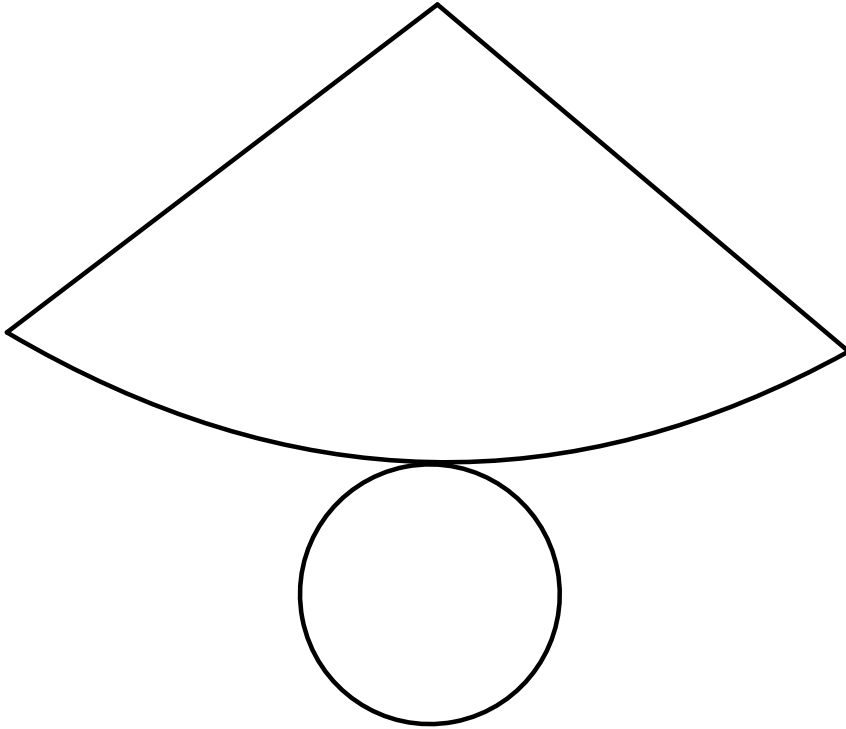
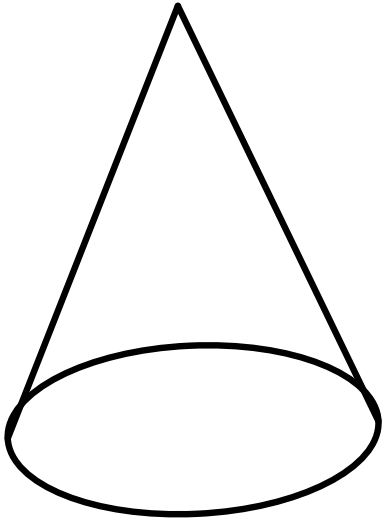

**Example**

Find the total surface area

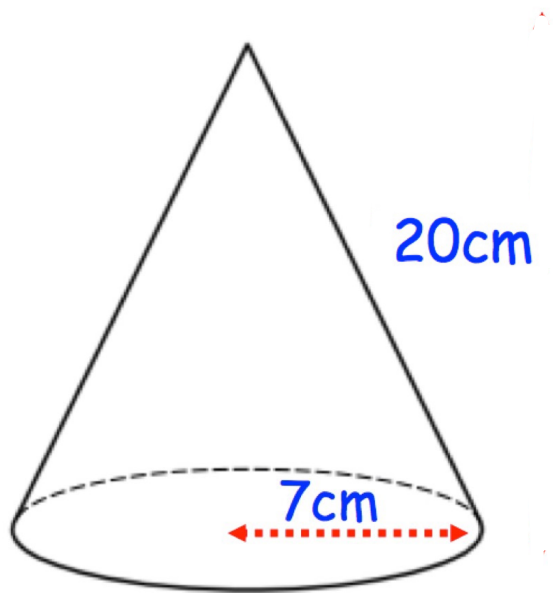

# Sphere

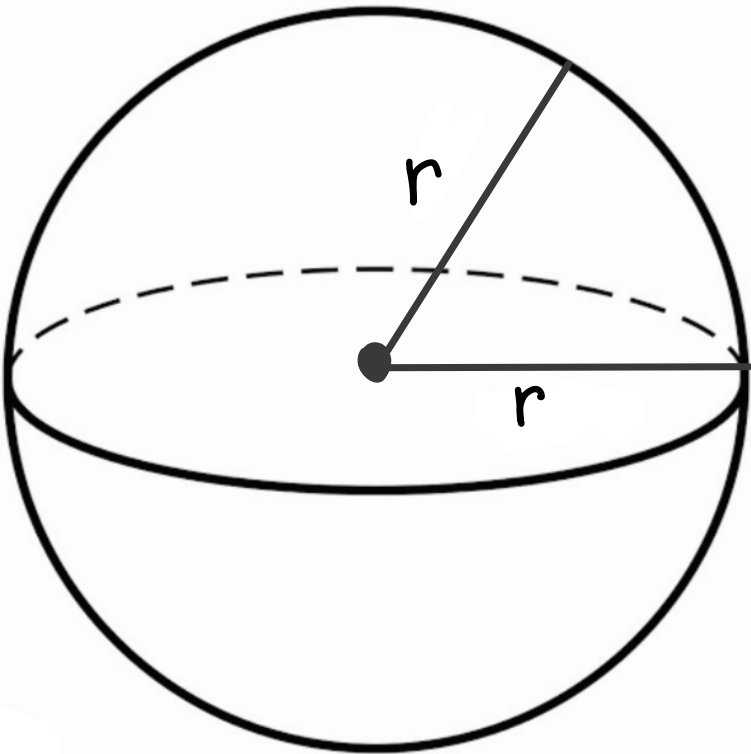

**Example**

Find the total surface area

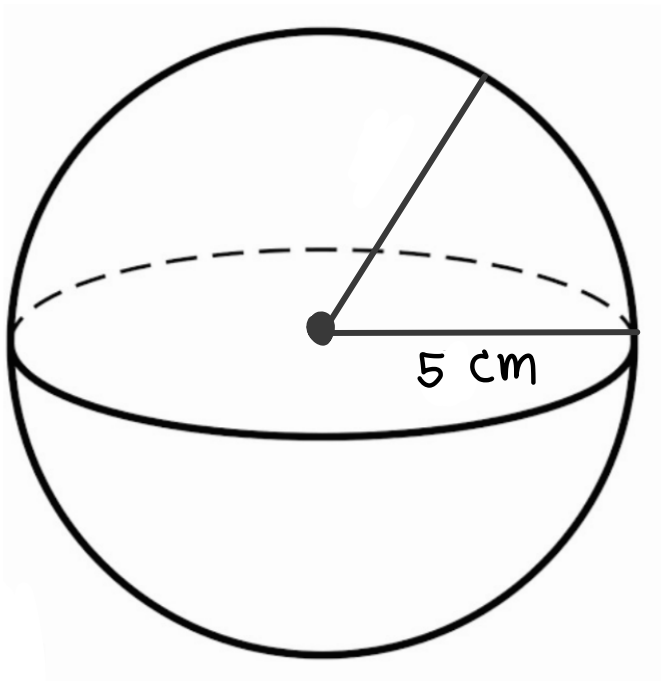

# Hemisphere

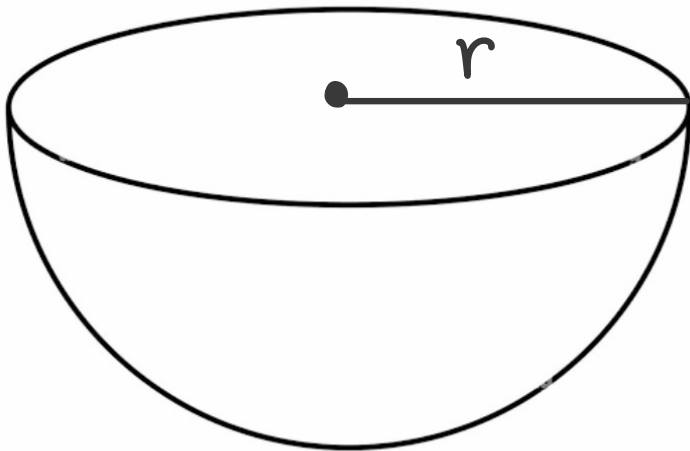

**Example**

Find the total surface area

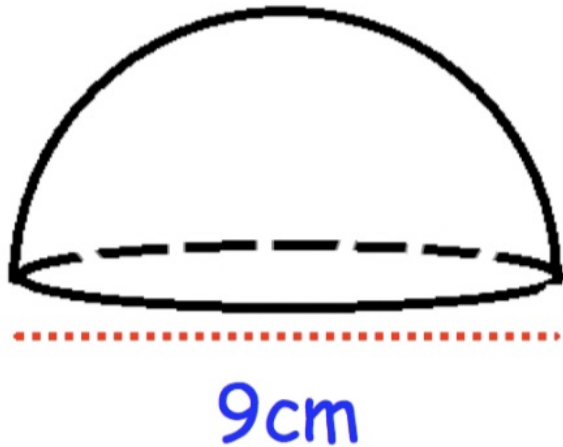

Note :

Note :

Example

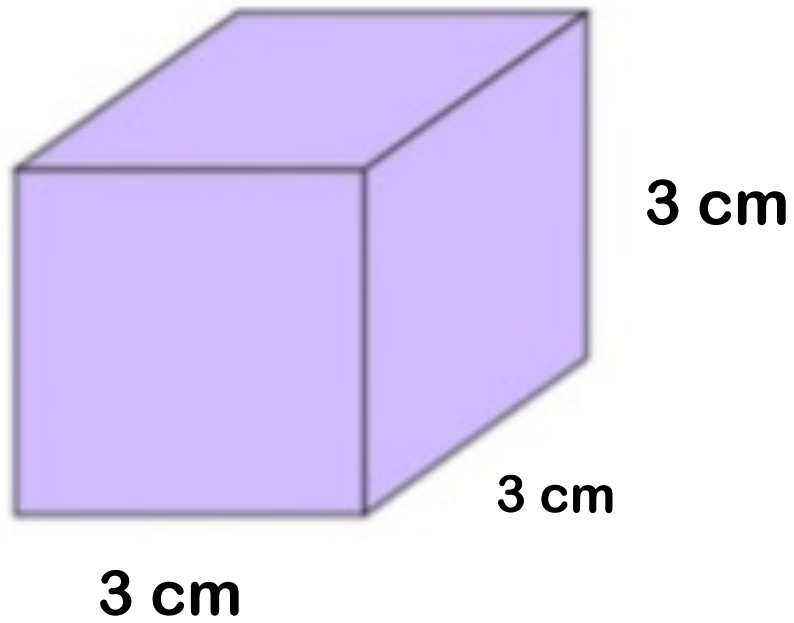

Find volume of cube

Example

Find the volume

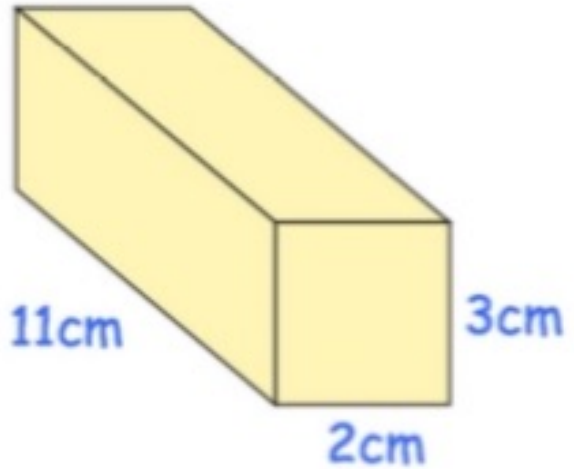

Example

Find the volume

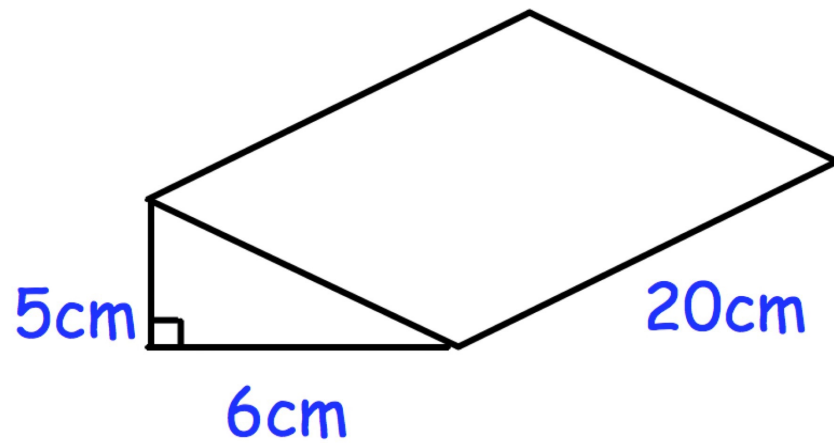

Example

Find the volume

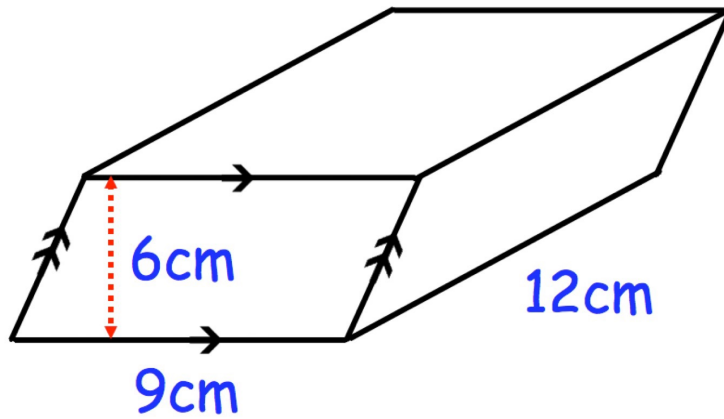

Example

Find the volume

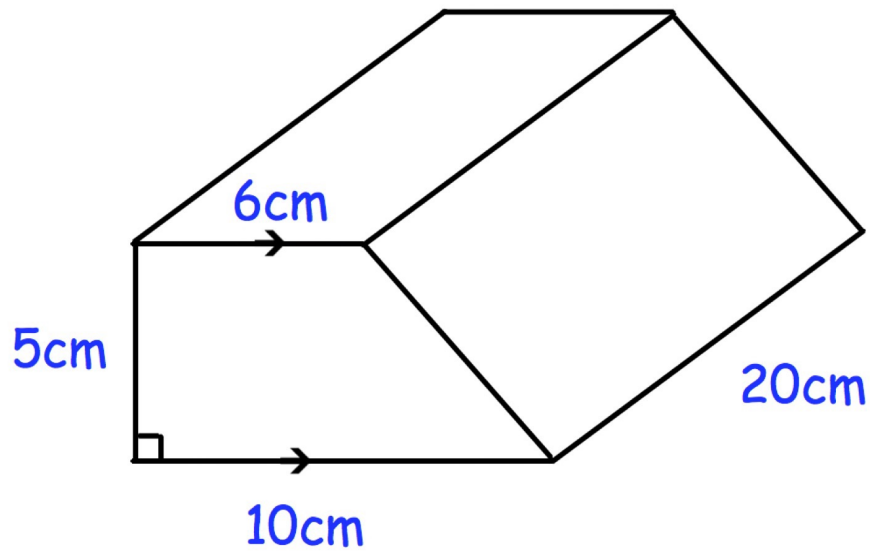

Cylinder

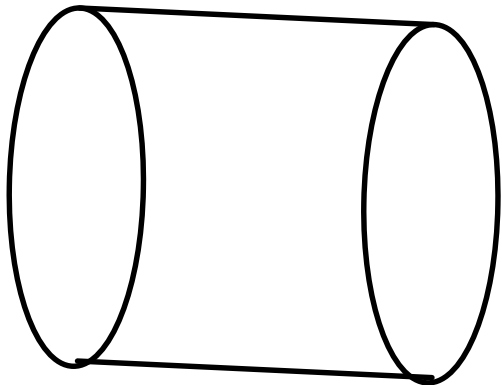
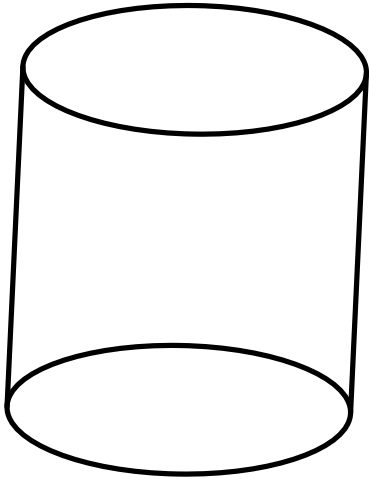

Example

Find the volume

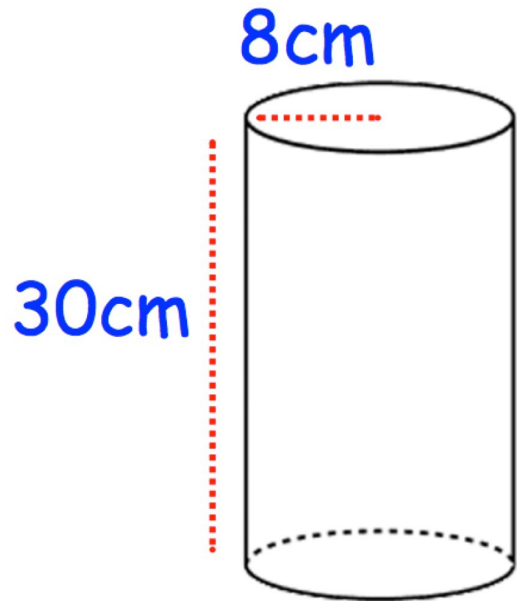

**Example** Find the volume

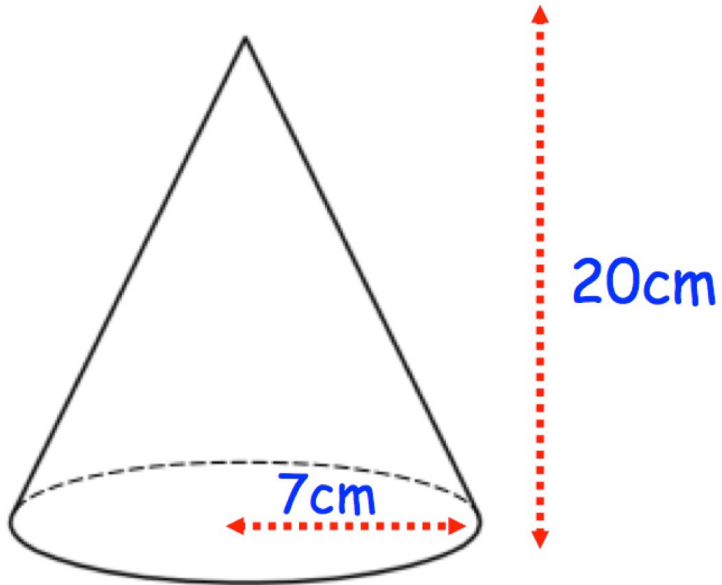

# Frustum

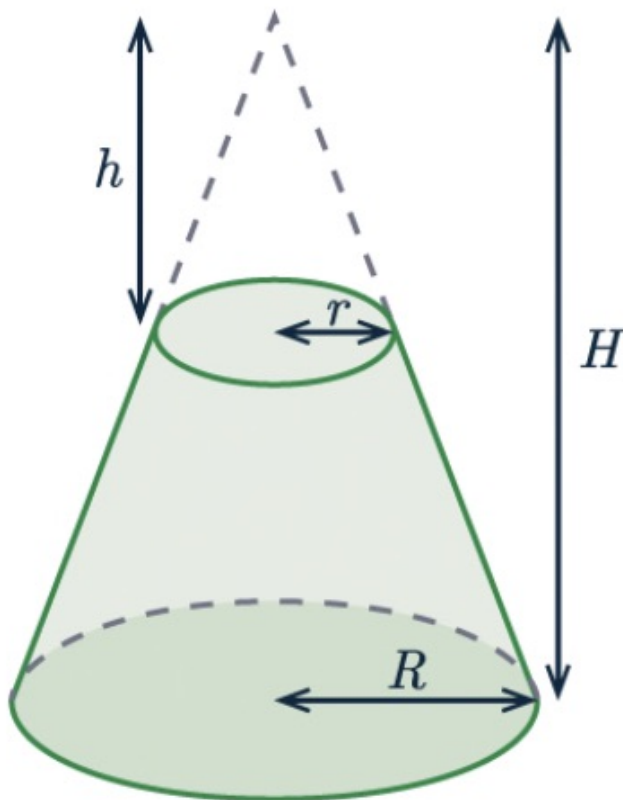

The frustum of a cone is the 3D shapes that is left over after you cut the top off

Example

Find the volume of frustum

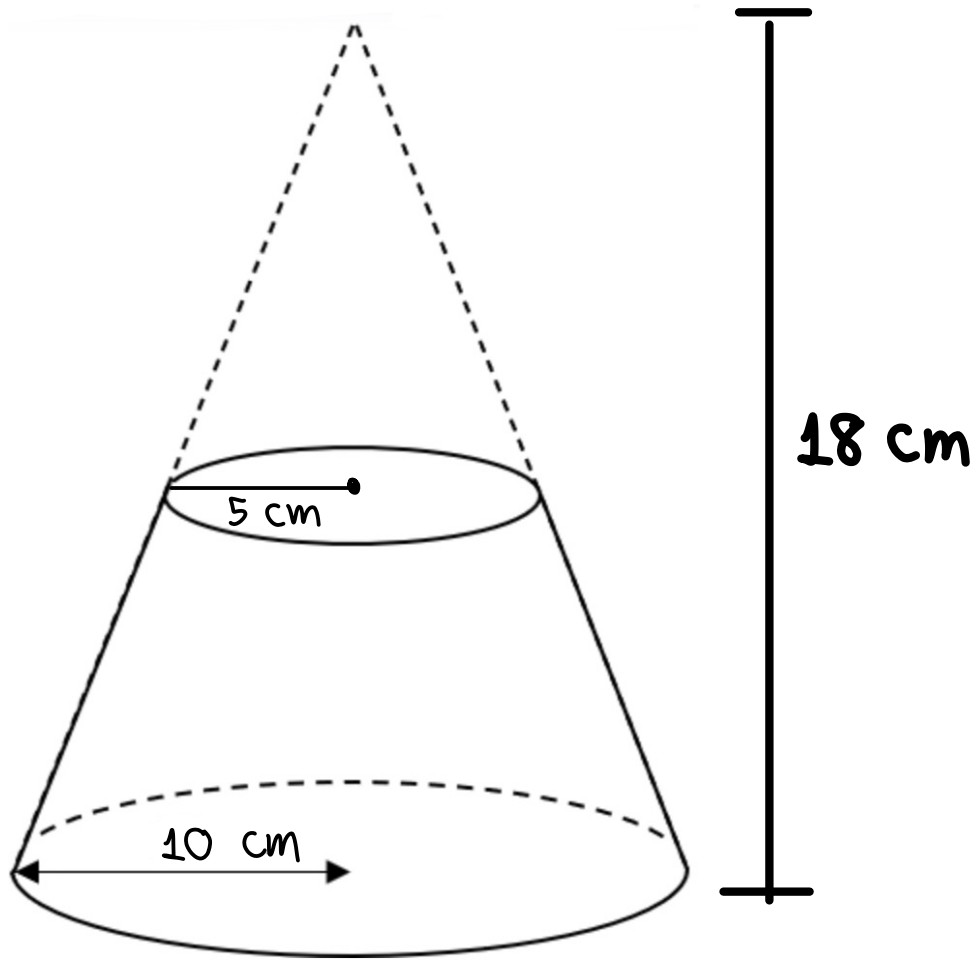

# Pyramid

Example

Find the volume

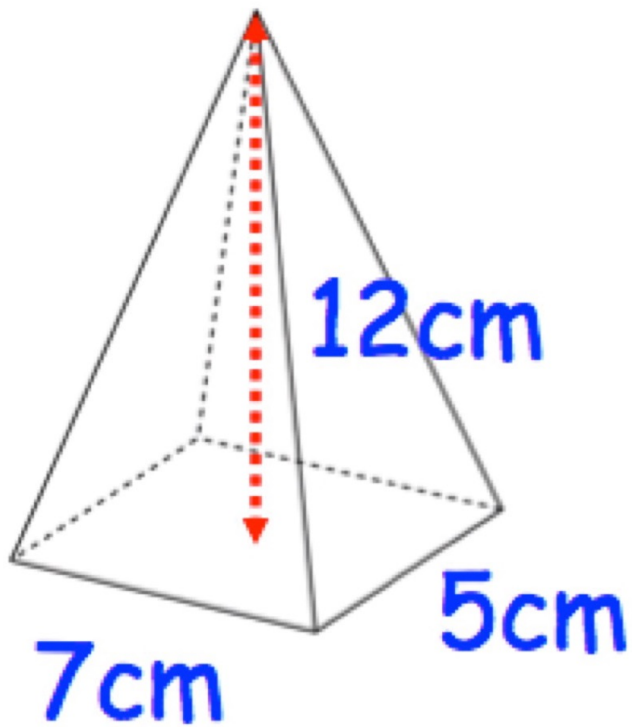

**Example** Find the volume

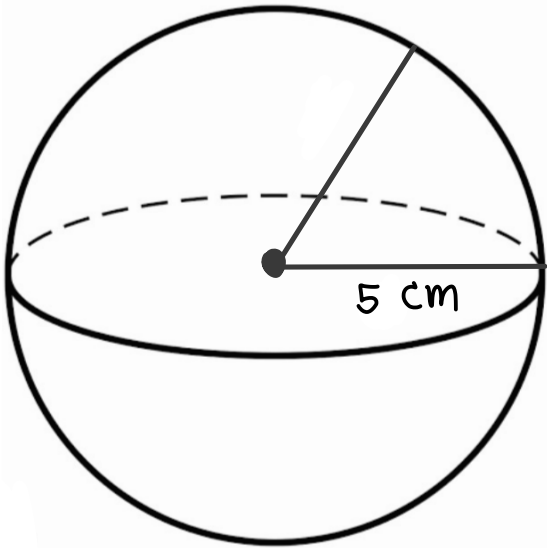

# Hemisphere

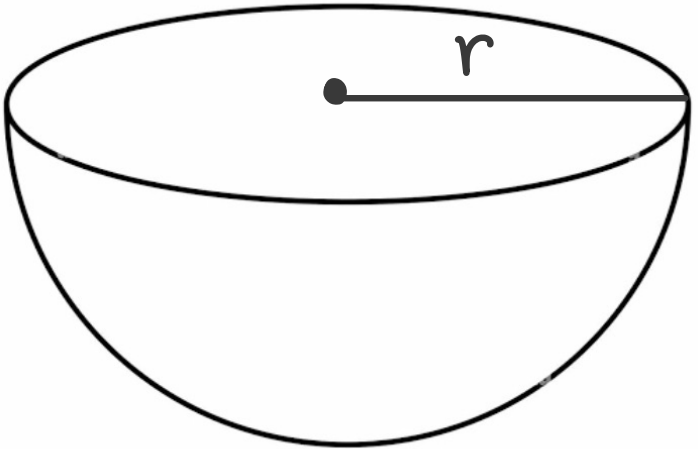

**Example** Find the volume

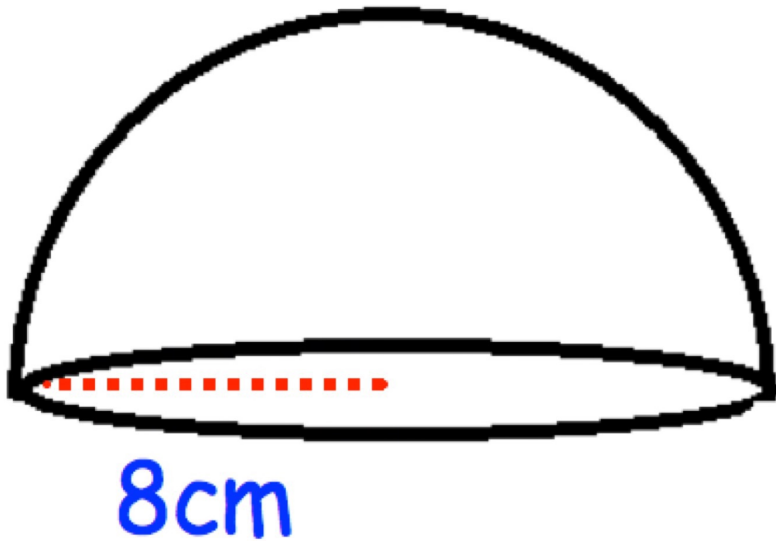

Q1.

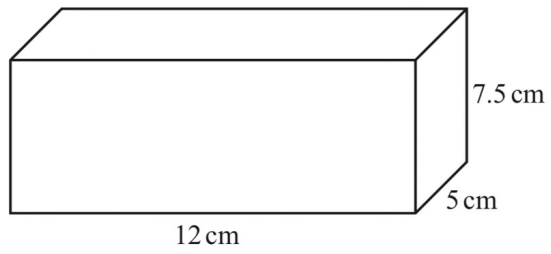

NOT TO  
SCALE

Calculate the total surface area of the cuboid.

.....cm<sup>2</sup> [3]

Q2.

A cone with height 14.8 cm has volume 275 cm<sup>3</sup>.

Calculate the radius of the cone.

[The volume,  $V$ , of a cone with radius  $r$  and height  $h$  is  $V = \frac{1}{3}\pi r^2 h$ .]

..... cm [3]

Q3.

Calculate the volume of

- (i) a solid cylinder with radius 6 cm and height 14 cm,

..... cm<sup>3</sup> [2]

- (ii) a solid hemisphere with radius 6 cm.  
[The volume,  $V$ , of a sphere with radius  $r$  is  $V = \frac{4}{3}\pi r^3$ .]

..... cm<sup>3</sup> [2]

(iii)

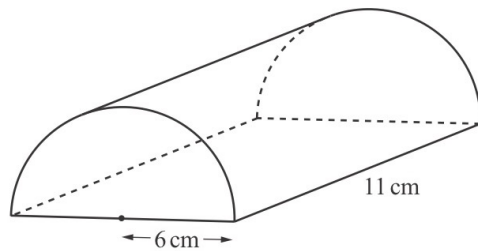

NOT TO  
SCALE

The diagram shows a half-cylinder of radius 6 cm and length 11 cm.

Calculate the volume of the half-cylinder.

..... cm<sup>3</sup> [2]

Q4.

A solid metal cone has radius 1.65 cm and slant height 4.70 cm.

- (a) Calculate the **total** surface area of the cone.

[The curved surface area,  $A$ , of a cone with radius  $r$  and slant height  $l$  is  $A = \pi rl$ .]

..... cm<sup>2</sup> [2]

- (b) Find the angle the slant height makes with the base of the cone.

..... [2]

- (c) (i) Calculate the volume of the cone.

[The volume,  $V$ , of a cone with radius  $r$  and height  $h$  is  $V = \frac{1}{3}\pi r^2 h$ .]

..... cm<sup>3</sup> [4]

- (ii) A metal sphere with radius 5 cm is melted down to make cones identical to this one.

Calculate the number of complete identical cones that are made.

[The volume,  $V$ , of a sphere with radius  $r$  is  $V = \frac{4}{3}\pi r^3$ .]

..... [4]

Q5.

(a)

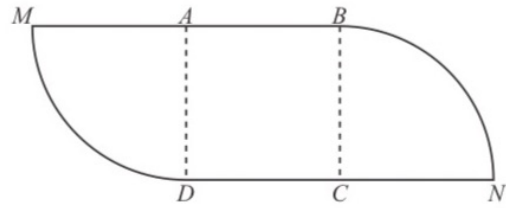

NOT TO SCALE

The diagram shows a shape made from a square  $ABCD$  and two equal sectors of a circle. The square has side 11 cm.  $MAB$  and  $DCN$  are straight lines.

(i) Calculate the area of the shape.

.....  $\text{cm}^2$  [3]

(ii) Calculate the perimeter of the shape.

..... cm [3]

Q6.

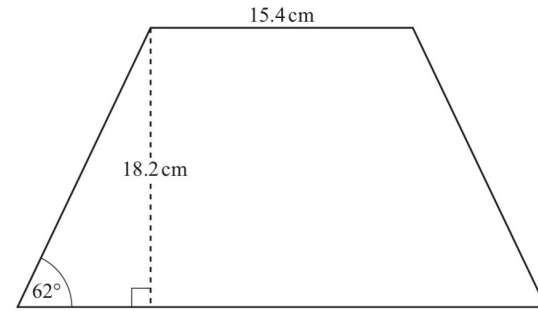

NOT TO SCALE

The diagram shows a trapezium. The trapezium has one line of symmetry.

Work out the area of the trapezium. [4]

Q7.

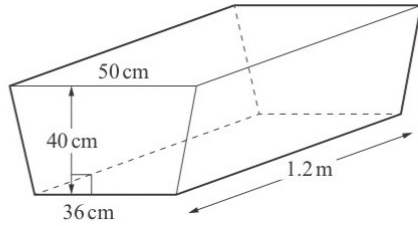

NOT TO SCALE

The diagram shows a water trough in the shape of a prism.  
The prism has a cross-section in the shape of an isosceles trapezium.  
The trough is completely filled with water.

(a) Show that the volume of water in the trough is 206.4 litres.

[3]

(b) The water from the trough is emptied at a rate of 600 ml per second.

Calculate the time taken, in minutes and seconds, for the trough to be emptied.

..... minutes ..... seconds [3]

(c) All the water from the trough is emptied into a vertical cylindrical tank.  
The depth of the water in the tank is 84 cm.



(i) Calculate the radius of the tank.

..... cm [3]

Q8.

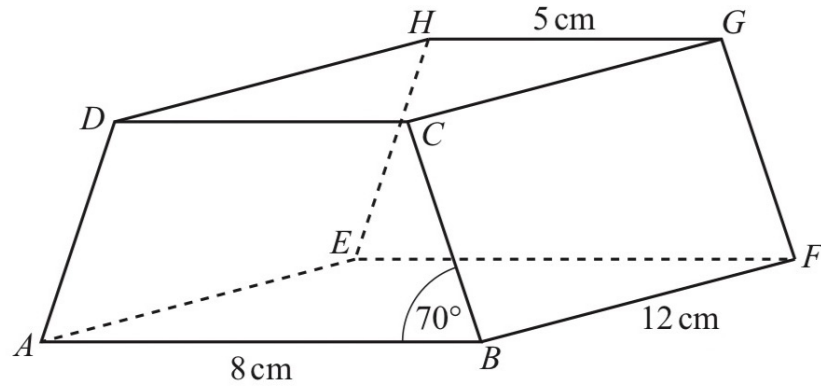

NOT TO  
SCALE

The diagram shows a prism with a rectangular base,  $ABFE$ .  
The cross-section,  $ABCD$ , is a trapezium with  $AD = BC$ .  
 $AB = 8$  cm,  $GH = 5$  cm,  $BF = 12$  cm and angle  $ABC = 70^\circ$ .

Calculate the total surface area of the prism. [6]

Q9.

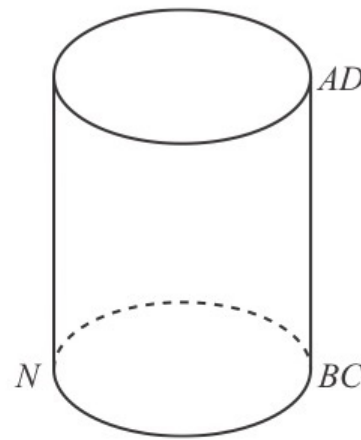
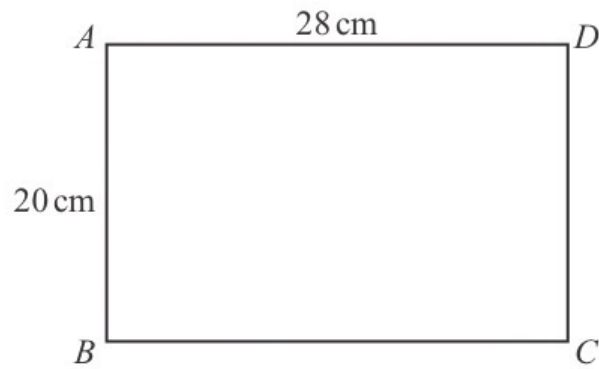

NOT TO  
SCALE

A rectangular sheet of paper  $ABCD$  is made into an open cylinder with the edge  $AB$  meeting the edge  $DC$ .  
 $AD = 28$  cm and  $AB = 20$  cm.

(i) Show that the radius of the cylinder is 4.46 cm, correct to 3 significant figures.

[2]

(ii) Calculate the volume of the cylinder.

.....  $\text{cm}^3$  [2]

Q10.

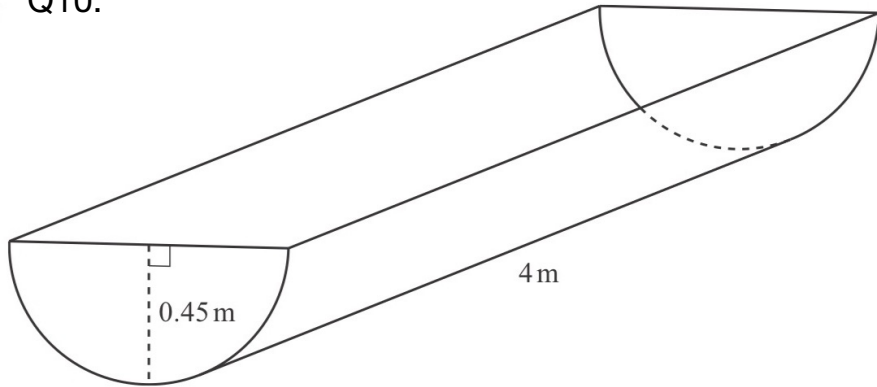

NOT TO SCALE

The diagram shows a horizontal container for water with a uniform cross-section. The cross-section is a semicircle. The radius of the semicircle is 0.45 m and the length of the container is 4 m.

(i) Calculate the volume of the container.

..... m<sup>3</sup> [2]

(ii)

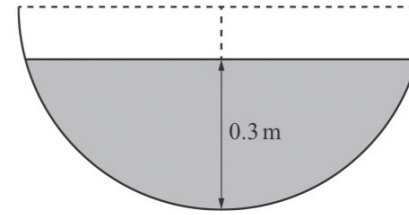

NOT TO SCALE

The greatest depth of the water in the container is 0.3 m. The diagram shows the cross-section.

Calculate the number of litres of water in the container. Give your answer correct to the nearest integer.

..... litres [6]

Q11.

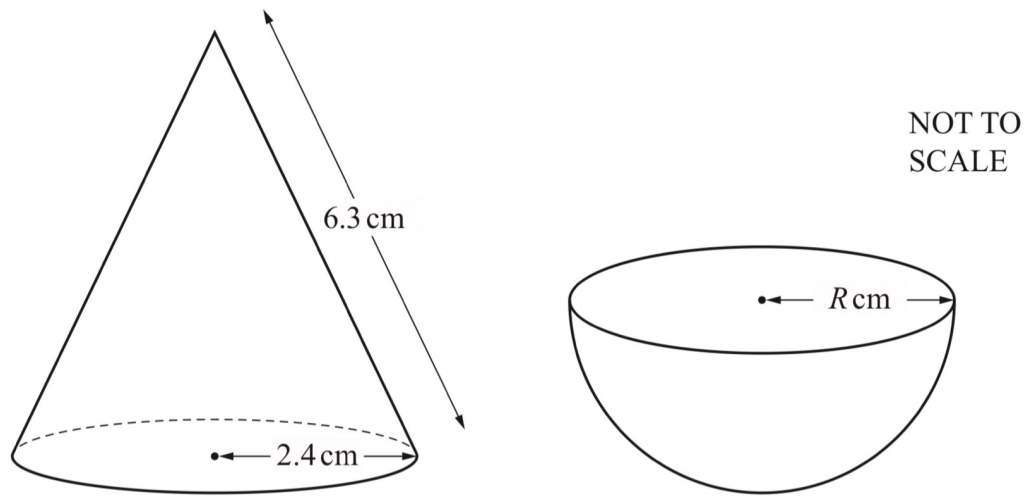

The diagram shows a solid cone and a solid hemisphere.  
The cone has radius 2.4 cm and slant height 6.3 cm.  
The hemisphere has radius  $R$  cm.  
The **total** surface area of the cone is equal to the **total** surface area of the hemisphere.

Calculate the value of  $R$ .

[The curved surface area,  $A$ , of a cone with radius  $r$  and slant height  $l$  is  $A = \pi r l$ .]

[The curved surface area,  $A$ , of a sphere with radius  $r$  is  $A = 4\pi r^2$ .] [4]

Q12.

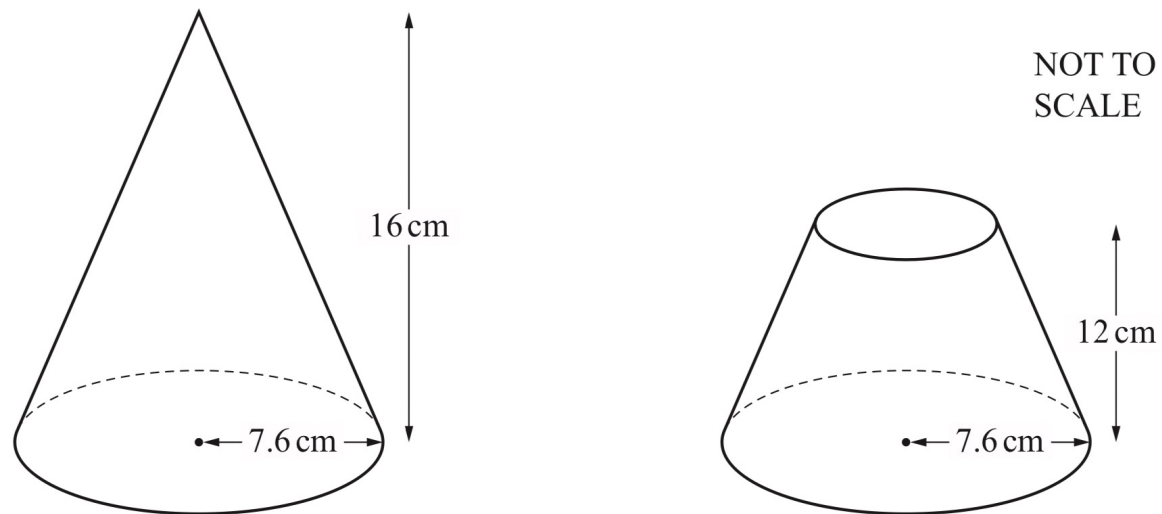

The diagram shows a solid cone with radius 7.6 cm and height 16 cm.  
A cut is made parallel to the base of the cone and the top section is removed.  
The remaining solid has height 12 cm, as shown in the diagram.

Calculate the volume of the remaining solid.

[The volume,  $V$ , of a cone with radius  $r$  and height  $h$  is  $V = \frac{1}{3}\pi r^2 h$ .] [4]

Q13.

The diagram shows a container for storing grain.

The container is made from a hemisphere, a cylinder and a cone, each with radius 2 m. The height of the cylinder is 5.2 m and the height of the cone is  $h$  m.

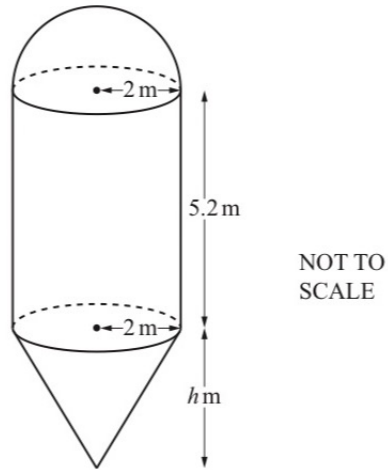

- (i) Calculate the volume of the hemisphere.  
Give your answer as a multiple of  $\pi$ .

[The volume,  $V$ , of a sphere with radius  $r$  is  $V = \frac{4}{3}\pi r^3$ .]

..... m<sup>3</sup> [2]

- (ii) The total volume of the container is  $\frac{88\pi}{3}$  m<sup>3</sup>.

Calculate the value of  $h$ .

[The volume,  $V$ , of a cone with radius  $r$  and height  $h$  is  $V = \frac{1}{3}\pi r^2 h$ .]

$h =$  ..... [4]

Q14. (a) The diagram shows a container for storing grain.

The container is made from a hemisphere, a cylinder and a cone, each with radius 2 m. The height of the cylinder is 5.2 m and the height of the cone is  $h$  m.

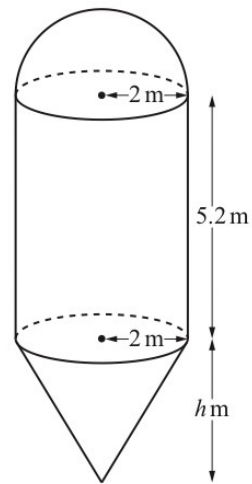

NOT TO SCALE

- (i) Calculate the volume of the hemisphere.  
Give your answer as a multiple of  $\pi$ .

[The volume,  $V$ , of a sphere with radius  $r$  is  $V = \frac{4}{3}\pi r^3$ .]

..... m<sup>3</sup> [2]

- (ii) The total volume of the container is  $\frac{88\pi}{3}$  m<sup>3</sup>.

Calculate the value of  $h$ .

[The volume,  $V$ , of a cone with radius  $r$  and height  $h$  is  $V = \frac{1}{3}\pi r^2 h$ .]

$h =$  ..... [4]

Q15.

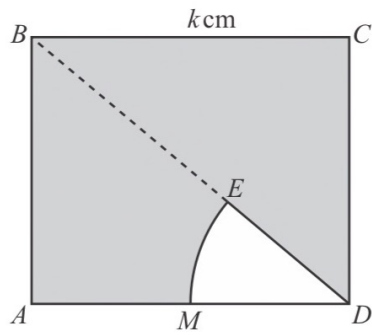

NOT TO  
SCALE

The diagram shows a square  $ABCD$  with side length  $k$  cm.  
 $MDE$  is a sector of a circle, centre  $D$ .  
 $E$  lies on the diagonal,  $BD$ , of the square.  
 $M$  is the midpoint of  $AD$ .

Find the percentage of the square that is shaded. [4]

Q16.

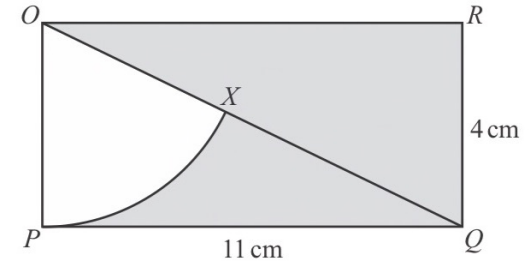

NOT TO  
SCALE

The diagram shows a rectangle  $OPQR$  with length 11 cm and width 4 cm.  
 $OQ$  is a diagonal and  $OPX$  is a sector of a circle, centre  $O$ .

Calculate the percentage of the rectangle that is shaded. [5]

Q17.

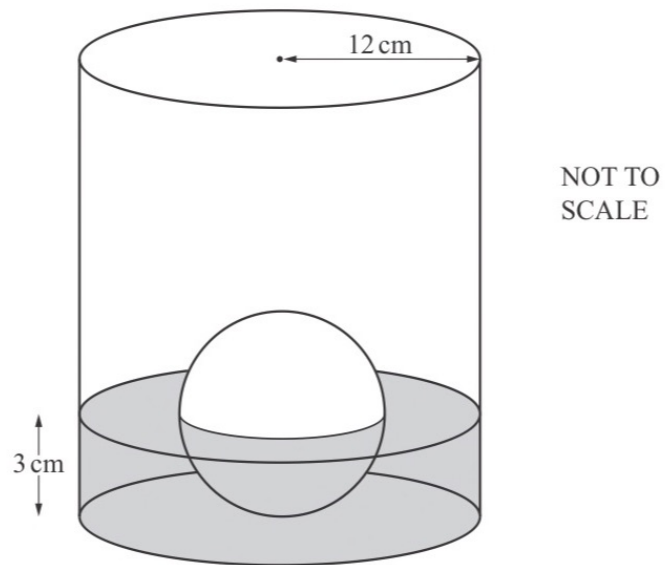

The diagram shows a cylinder containing water.  
There is a solid metal sphere touching the base of the cylinder.  
Half of the sphere is in the water.

The radius of the cylinder is 12 cm and the radius of the sphere is 3 cm.

(a) The sphere is removed from the cylinder and the level of the water decreases by  $h$  cm.

Show that  $h = 0.125$ .

[The volume,  $V$ , of a sphere with radius  $r$  is  $V = \frac{4}{3}\pi r^3$ .] [3]

Q18.

(c)

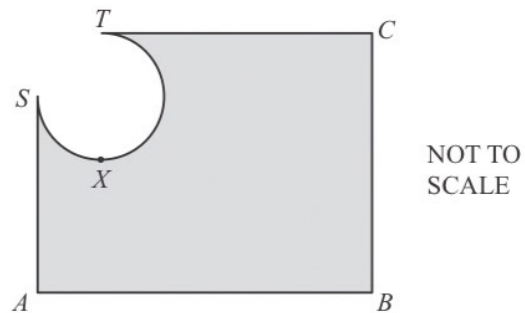
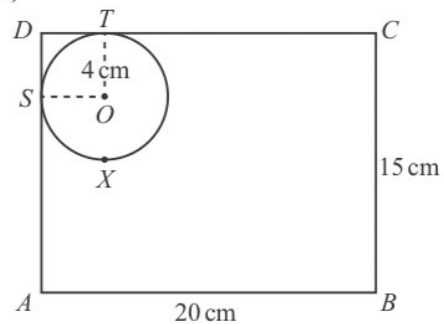

- (i)  $ABCD$  is a rectangle with  $AB = 20$  cm and  $BC = 15$  cm.  
 $S$ ,  $X$  and  $T$  are points on a circle centre  $O$ , such that  $DSA$  and  $DTC$  are tangents to the circle.  
 The radius of the circle is 4 cm and  $TX$  is a diameter of the circle.  
 The shape  $DSXT$  is removed from the corner of the rectangle, leaving the shaded shape shown in the second diagram.

Calculate the area of the shaded shape.

.....  $\text{cm}^2$  [5]

- (ii) Calculate the perimeter of the shaded shape.

..... cm [3]

Q19.

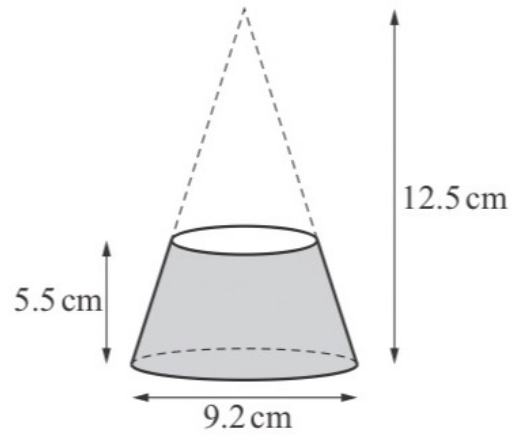

NOT TO  
SCALE

A solid is made by cutting a small cone from a larger cone, as shown in the diagram.  
The height of the larger cone is 12.5 cm.  
The height of the solid is 5.5 cm.  
The diameter of the base of the larger cone is 9.2 cm.

Work out the volume of the solid.

[The volume,  $V$ , of a cone with radius  $r$  and height  $h$  is  $V = \frac{1}{3}\pi r^2 h$ .]

.....  $\text{cm}^3$  [4]

Q20. (a)

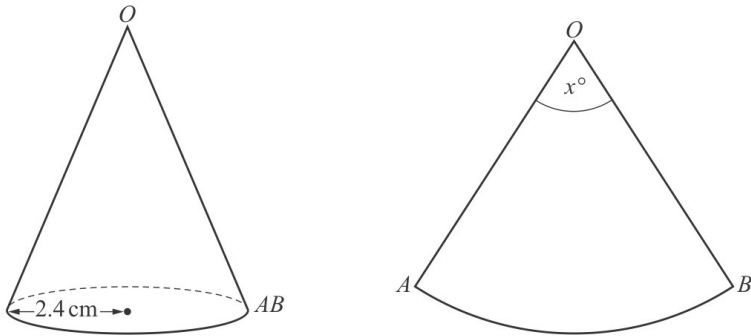

The volume of a paper cone of radius 2.4 cm is  $95.4 \text{ cm}^3$ .  
The paper is cut along the slant height from  $O$  to  $AB$ .  
The cone is opened to form a sector  $OAB$  of a circle with centre  $O$ .

Calculate the sector angle  $x^\circ$ .  
[The volume,  $V$ , of a cone with radius  $r$  and height  $h$  is  $V = \frac{1}{3}\pi r^2 h$ .] [6]

- (b) An empty fuel tank is filled using a cylindrical pipe with diameter 8 cm.  
Fuel flows along this pipe at a rate of 2 metres per second.  
It takes 24 minutes to fill the tank.

Calculate the capacity of the tank.  
Give your answer in litres.

..... litres [4]

Q21.

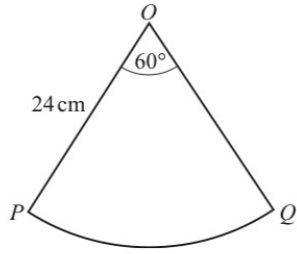

NOT TO SCALE

The diagram shows a sector  $OPQ$  of a circle with centre  $O$  and radius 24 cm. The sector angle is  $60^\circ$ .

A cone is made from this sector by joining  $OP$  to  $OQ$ .

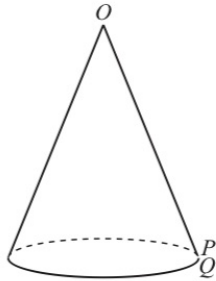

NOT TO SCALE

Calculate the volume of the cone.

[The volume,  $V$ , of a cone with radius  $r$  and height  $h$  is  $V = \frac{1}{3}\pi r^2 h$ .]

.....  $\text{cm}^3$  [6]

# Pythagoras Theorem and Trigonometry

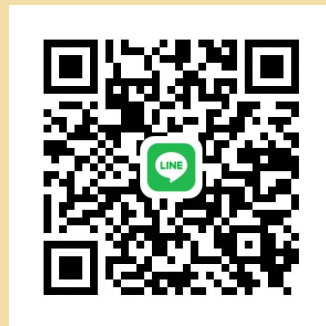

By .... Kru ชี

# Pythagoras Theorem



# The ratio between sides in right angle triangles

# How to remember

Calculate missing length by using  
SIN , COS , TAN

## Example

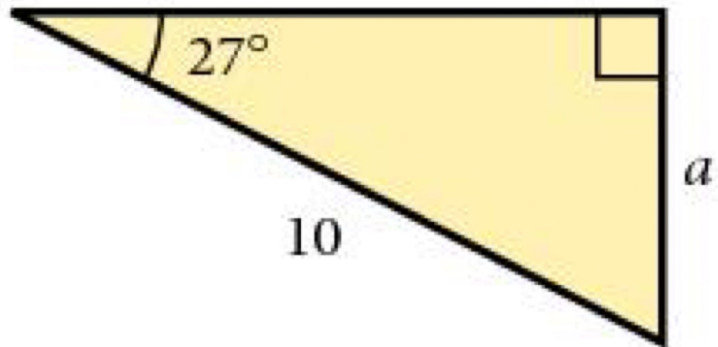

Calculate missing angle by using  
 $\text{SIN}^{-1}$ ,  $\text{COS}^{-1}$ ,  $\text{TAN}^{-1}$

## Example

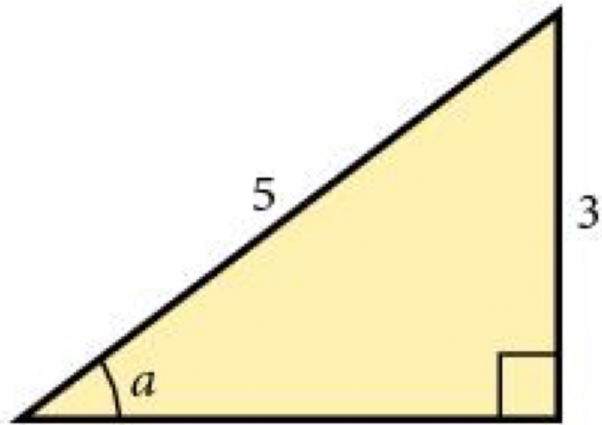

## 3-D shapes

# Cube

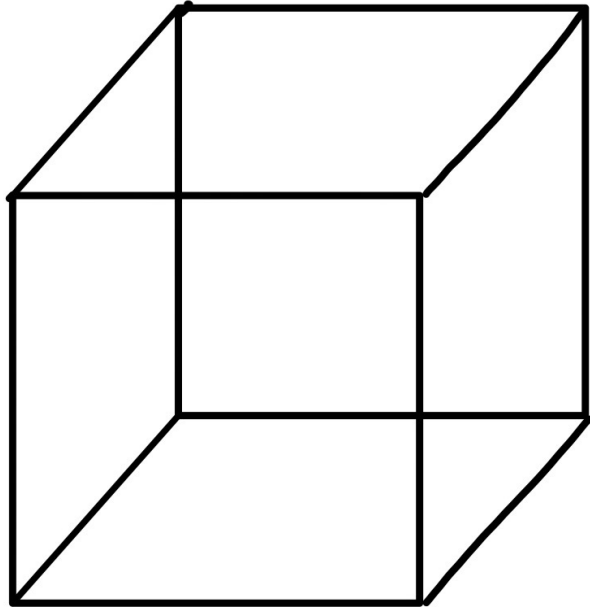

# Cuboid

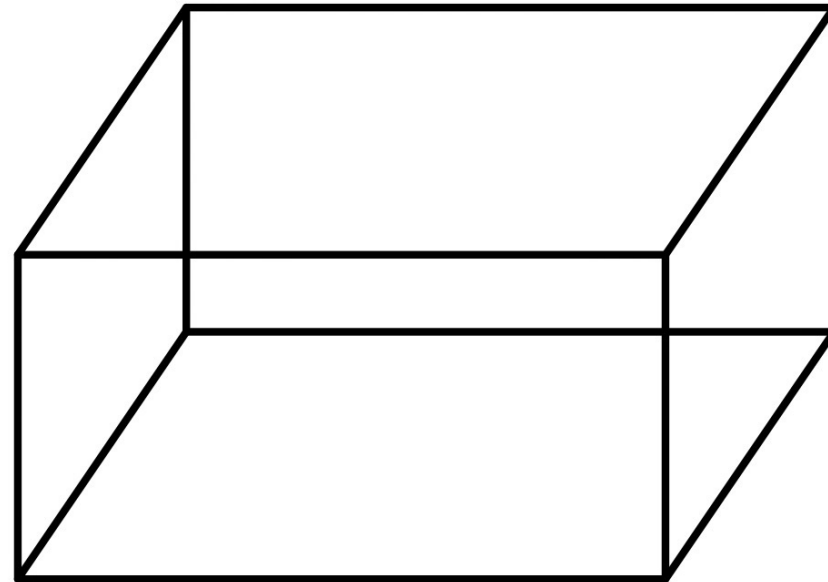

# Prism

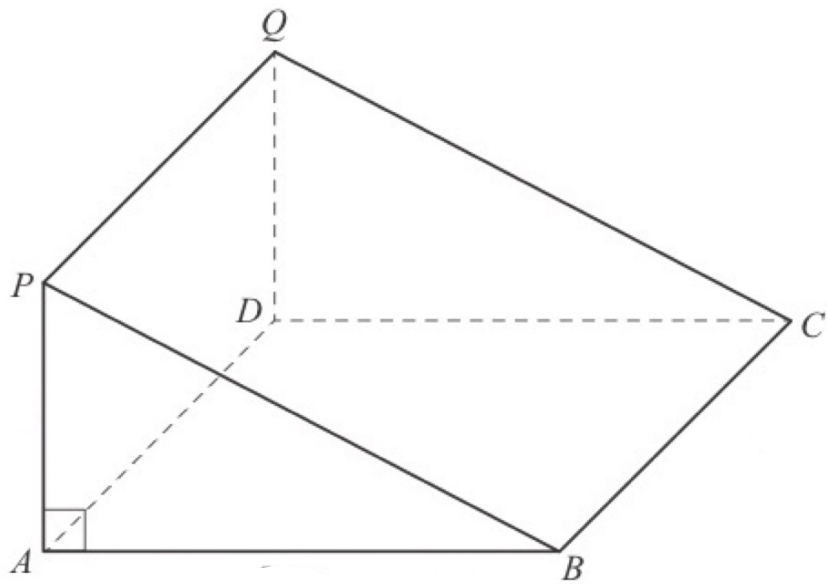

# Pyramid

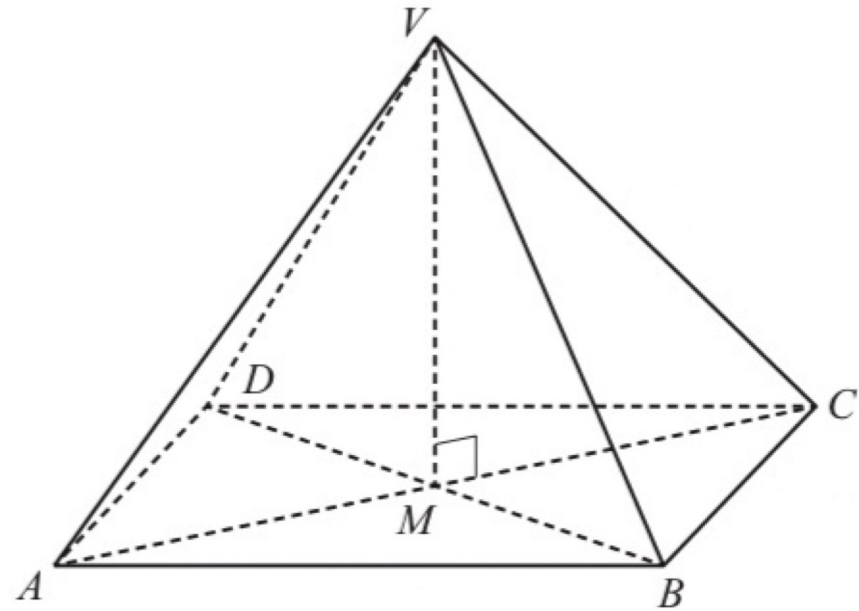

Rules

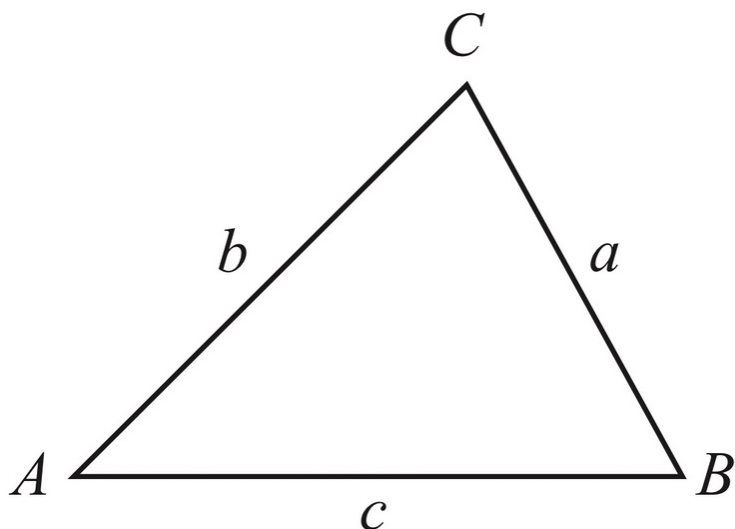

In any triangle  $ABC$

**Sine Rule**  $\frac{a}{\sin A} = \frac{b}{\sin B} = \frac{c}{\sin C}$

**Cosine Rule**  $a^2 = b^2 + c^2 - 2bc \cos A$

**Area of triangle**  $= \frac{1}{2} ab \sin C$



## Area of triangles



## Example

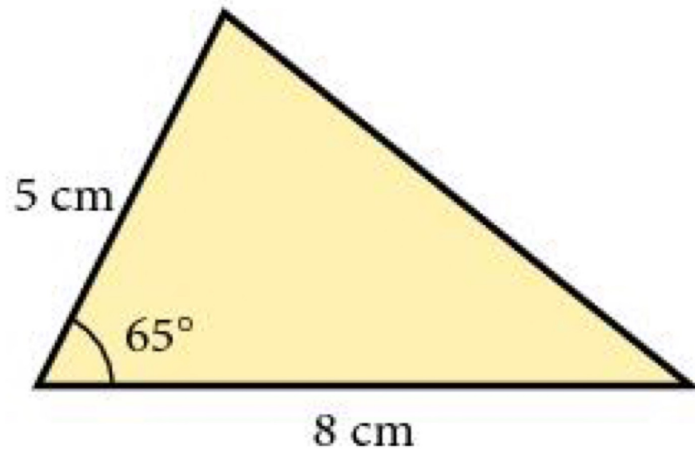



## Example

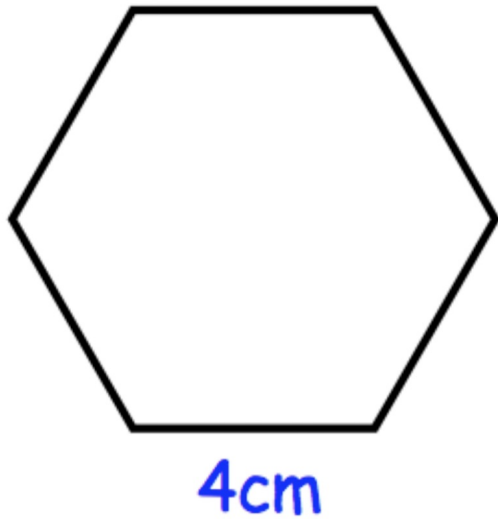

A regular hexagon has side length 4cm.

Calculate the area of the hexagon.



## Sine Rule



## Example

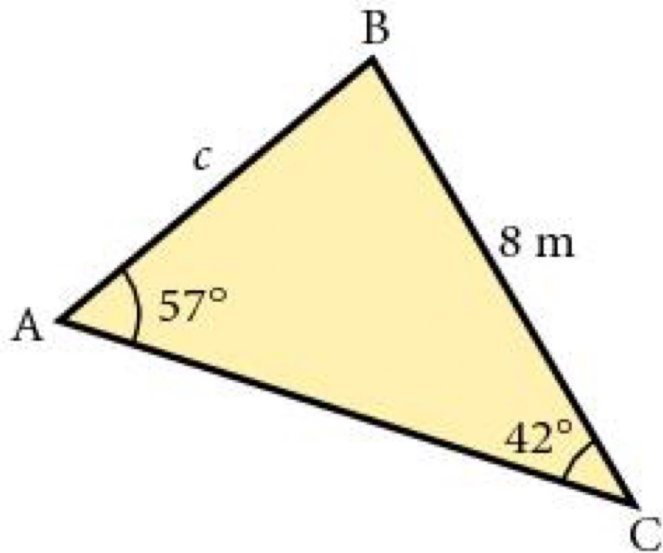



## Example

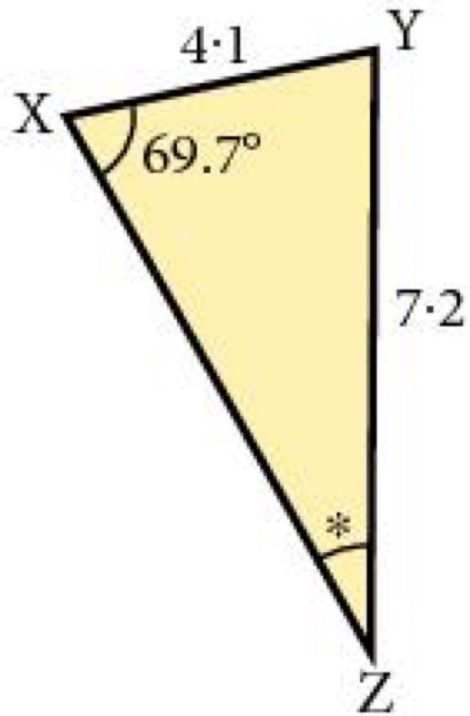



## Example

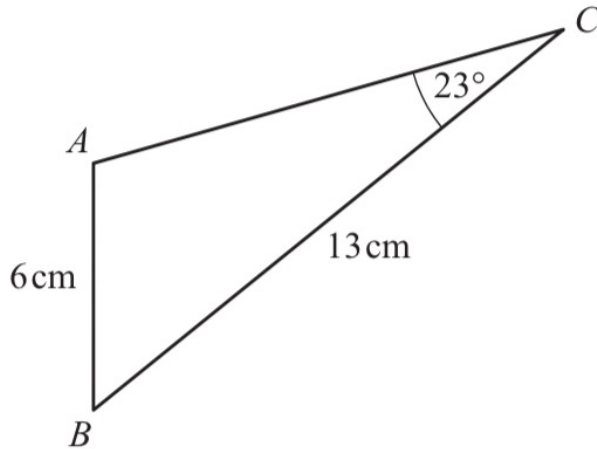

In triangle  $ABC$ ,  $AB = 6$  cm,  $BC = 13$  cm and angle  $ACB = 23^\circ$ .  
Calculate angle  $BAC$ , which is obtuse.



## Cosine Rule



## Example

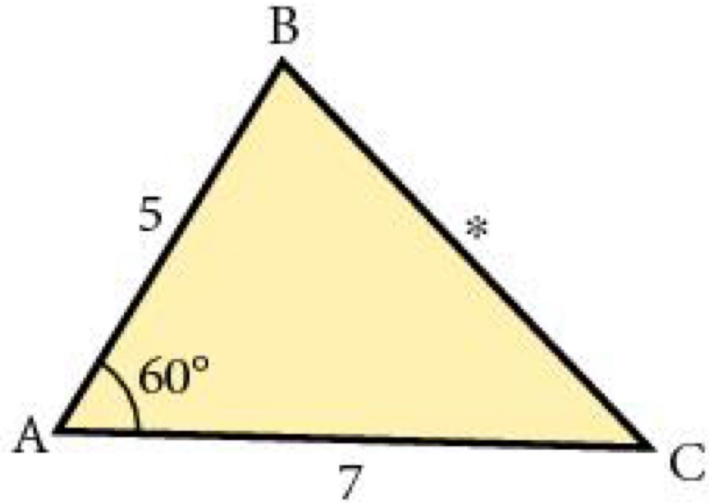



## Example

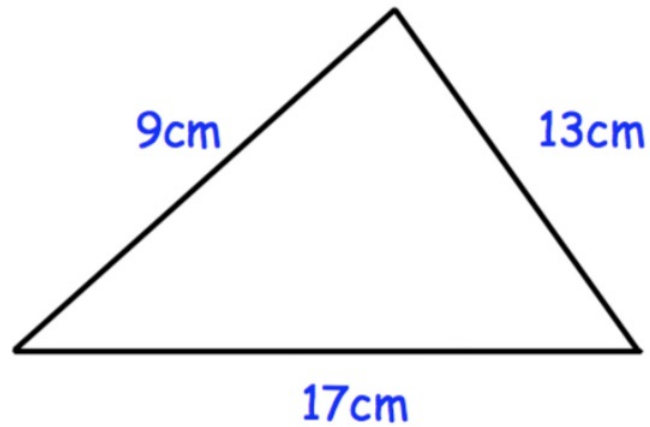

Calculate the smallest angle in the triangle.

# Bearing

Find the bearing of A from B

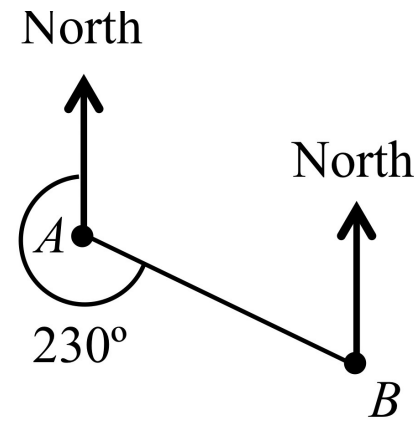
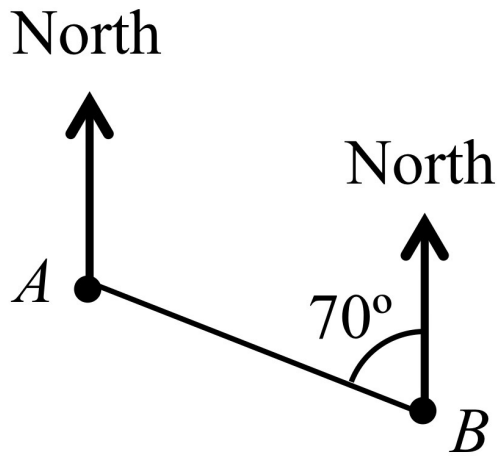

Angles of elevation

Angles of depression

Q1.

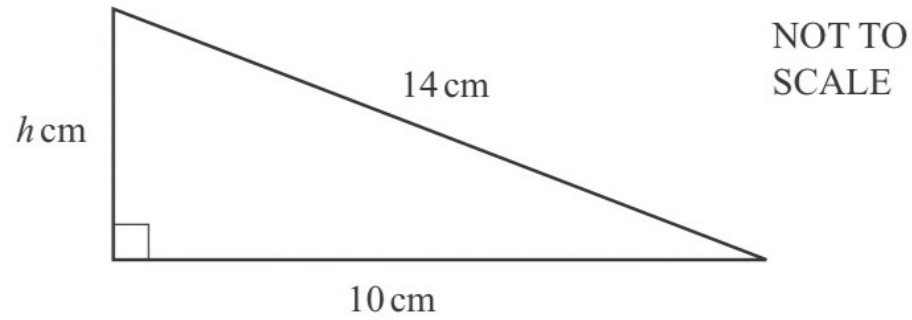

The diagram shows a right-angled triangle.

(a) Calculate the value of  $h$ .

$h = \dots\dots\dots$  [3]

(b) Find the perimeter of this triangle.

$\dots\dots\dots$  cm [1]

Q2. (a)

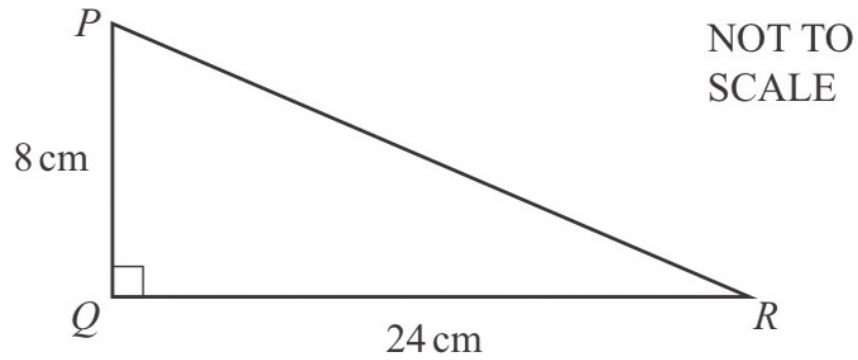

(i) Calculate the area of triangle  $PQR$ .

.....  $\text{cm}^2$  [2]

(ii) Calculate angle  $PRQ$ .

Angle  $PRQ =$  ..... [2]

Q3.

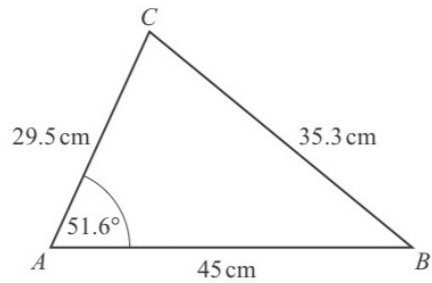

NOT TO  
SCALE

In triangle  $ABC$ ,  $AB = 45$  cm,  $AC = 29.5$  cm,  $BC = 35.3$  cm and angle  $CAB = 51.6^\circ$ .

(i) Calculate angle  $ABC$ .

Angle  $ABC = \dots\dots\dots$  [3]

(ii) Calculate the area of triangle  $ABC$ .

$\dots\dots\dots$   $\text{cm}^2$  [2]

Q4.

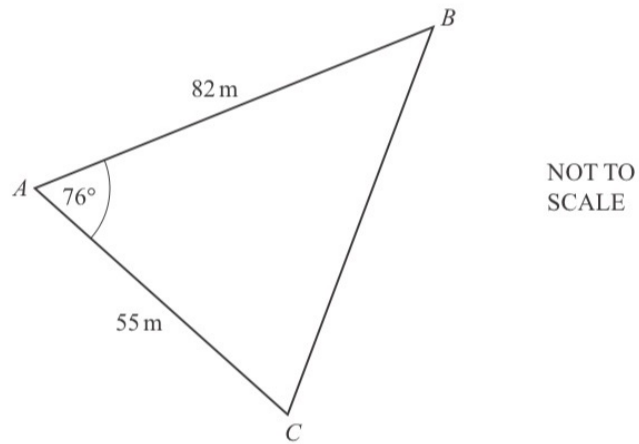

The diagram shows a field  $ABC$ .

(a) Calculate  $BC$ .

$BC = \dots\dots\dots\text{ m}$  [3]

(b) Calculate angle  $ACB$ .

Angle  $ACB = \dots\dots\dots$  [3]

Q5. (a)

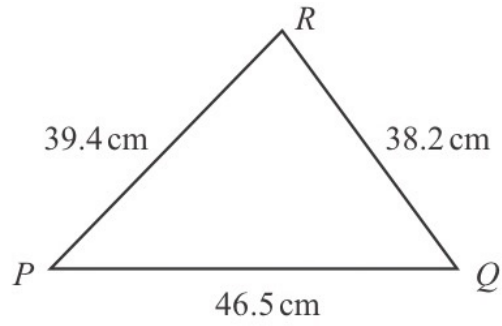

NOT TO  
SCALE

(i) Calculate angle  $QPR$ .

Angle  $QPR = \dots\dots\dots$  [4]

(ii) Find the shortest distance from  $Q$  to  $PR$ .

$\dots\dots\dots$  cm [3]

Q6.

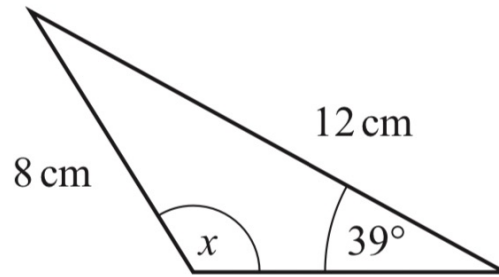

NOT TO  
SCALE

Calculate the **obtuse** angle  $x$  in this triangle.

$x = \dots\dots\dots$  [3]

Q7.

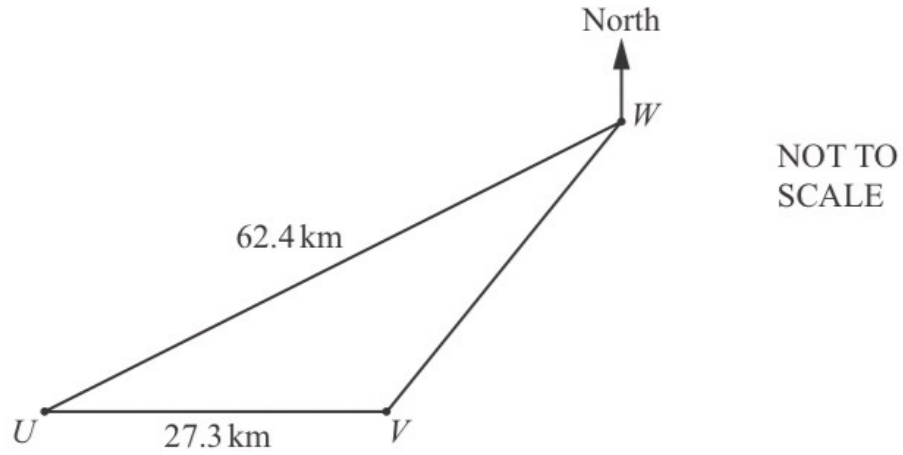

The diagram shows the position of three towns,  $U$ ,  $V$  and  $W$ .  
 $U$  is due west of  $V$  and angle  $UVW = 125^\circ$ .

Calculate the bearing of  $U$  from  $W$ .

..... [4]

Q8.

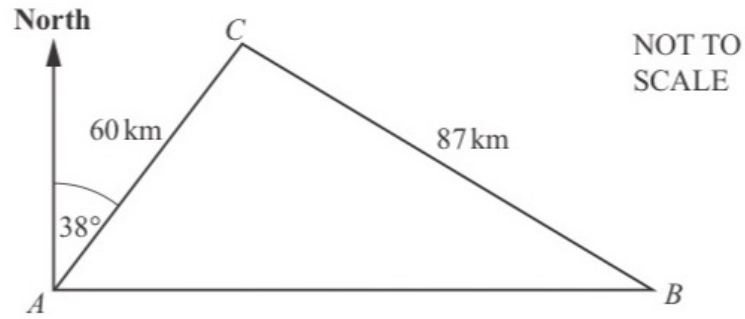

The diagram shows the straight roads between town  $A$ , town  $B$  and town  $C$ .  
 $AC = 60$  km,  $CB = 87$  km and  $B$  is due east of  $A$ .  
The bearing of  $C$  from  $A$  is  $038^\circ$ .

- (a) Show that angle  $ACB = 95.1^\circ$ , correct to 1 decimal place. [5]
- (b) Without stopping, a car travels from town  $A$  to town  $C$  then to town  $B$ , before returning directly to town  $A$ .  
The total time taken for the journey is 3 hours 20 minutes.
- Calculate the average speed of the car for this journey.  
Give your answer in kilometres per hour.

..... km/h [6]

Q9.

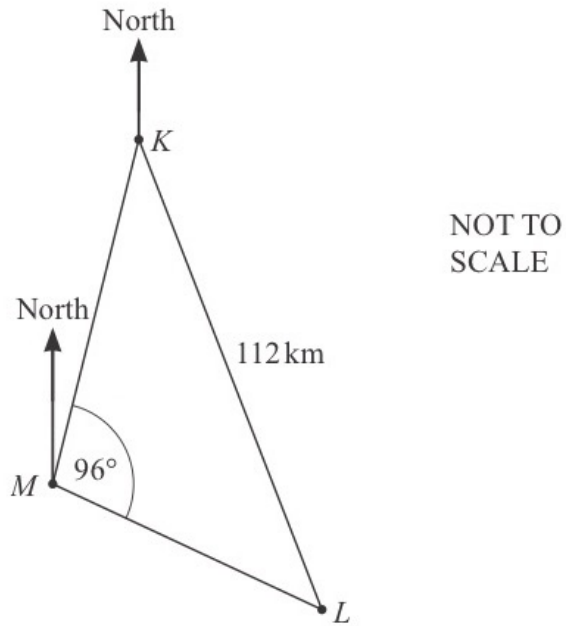

The diagram shows the positions of a lighthouse,  $L$ , and two ships,  $K$  and  $M$ .  
The bearing of  $L$  from  $K$  is  $155^\circ$  and  $KL = 112$  km.  
The bearing of  $K$  from  $M$  is  $010^\circ$  and angle  $KML = 96^\circ$ .

Find the bearing and distance of ship  $M$  from the lighthouse,  $L$ .

Bearing .....

Distance ..... km [5]

Q10.

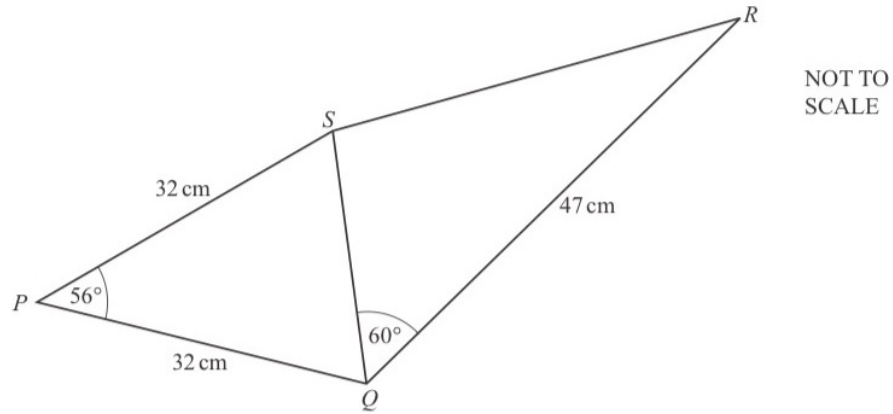

The diagram shows a quadrilateral  $PQRS$  formed from two triangles,  $PQS$  and  $QRS$ . Triangle  $PQS$  is isosceles, with  $PQ = PS = 32$  cm and angle  $SPQ = 56^\circ$ .  $QR = 47$  cm and angle  $SQR = 60^\circ$ .

(i) Calculate  $SR$ .

$SR = \dots\dots\dots$  cm [4]

(ii) Calculate the shortest distance from  $P$  to  $SQ$ .

$\dots\dots\dots$  cm [3]

Q11.

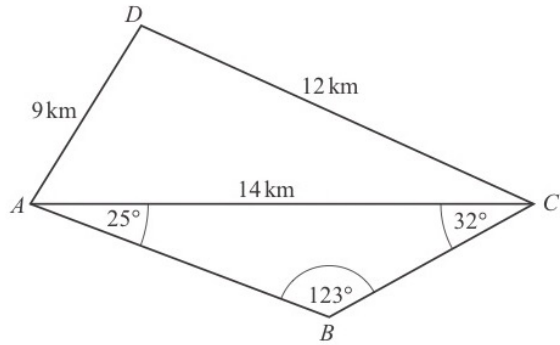

NOT TO SCALE

(a) Calculate angle  $ACD$ .

Angle  $ACD = \dots\dots\dots$  [4]

(b) Show that  $BC = 7.05$  km, correct to 2 decimal places.

[3]

(c) Calculate the shortest distance from  $B$  to  $AC$ .

$\dots\dots\dots$  km [3]

(d) Calculate the length of the straight line  $BD$ .

$BD = \dots\dots\dots$  km [4]

(e)  $C$  is due east of  $A$ .

Find the bearing of  $D$  from  $C$ .

$\dots\dots\dots$  [2]

Q12.

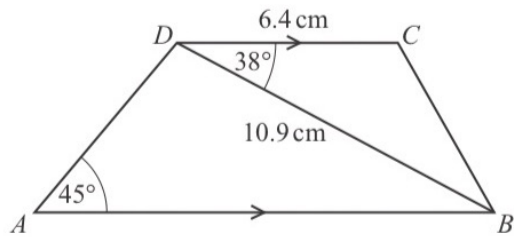

NOT TO SCALE

*ABCD* is a trapezium with *DC* parallel to *AB*.  
*DC* = 6.4 cm, *DB* = 10.9 cm, angle *CDB* = 38° and angle *DAB* = 45°.

(a) Find *CB*.

*CB* = ..... cm [3]

(c) Calculate the area of the trapezium.

(b) (i) Find angle *ADB*.

Angle *ADB* = ..... [1]

(ii) Find *AB*.

*AB* = ..... cm [3]

..... cm<sup>2</sup> [3]

Q13. The diagram shows a cuboid.

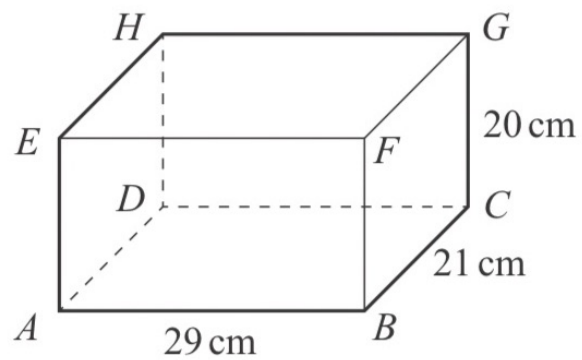

NOT TO  
SCALE

(i) Calculate the length  $AG$ .

$AG = \dots\dots\dots$  cm [3]

Q14.

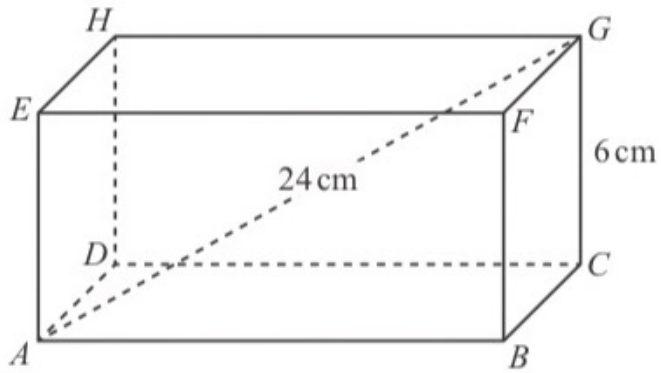

NOT TO  
SCALE

The diagram shows a cuboid  $ABCDEFGH$ .  
 $CG = 6$  cm,  $AG = 24$  cm and  $AB = 2BC$ .

(a) Calculate  $AB$ .

(b) Calculate the angle between  $AG$  and the base  $ABCD$ .

..... [3]

$AB =$  ..... cm [4]

Q15. (a)

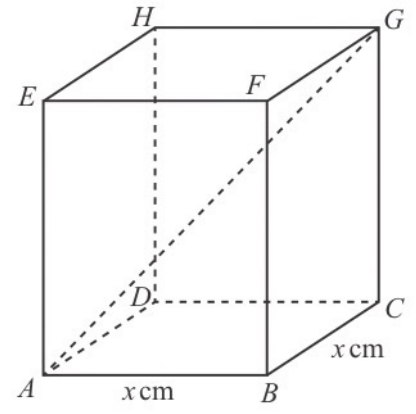

NOT TO SCALE

$ABCDEFGH$  is a cuboid with a square base of side  $x$  cm.  
 $CG = 20$  cm and  $AG = 28$  cm.

Calculate the value of  $x$ .

$x = \dots\dots\dots$  [4]

(b)

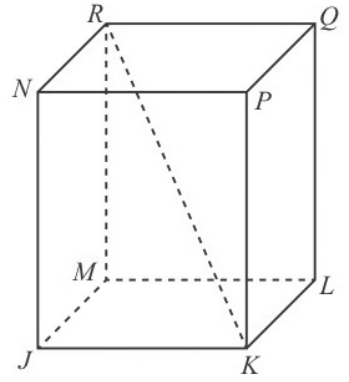

NOT TO SCALE

The diagram shows a different cuboid  $JKLMNPQR$ .  
 $MR = 30$  cm correct to the nearest centimetre.  
 $KR = 37$  cm correct to the nearest centimetre.

Calculate the lower bound of the angle between  $KR$  and the base  $JKLM$  of the cuboid.

$\dots\dots\dots$  [4]

Q16.

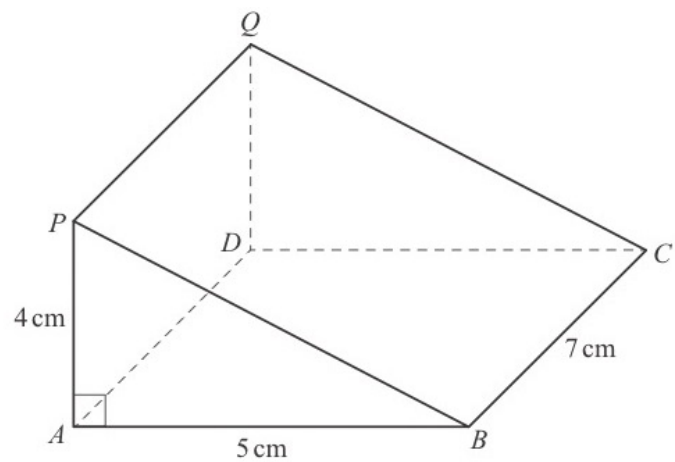

NOT TO  
SCALE

The diagram shows a triangular prism  $ABCDQP$  of length 7 cm.  
The cross-section is triangle  $PAB$  with  $PA = 4$  cm,  $AB = 5$  cm and angle  $PAB = 90^\circ$ .

Calculate the angle between the line  $PC$  and the base  $ABCD$ .

..... [4]

Q17.

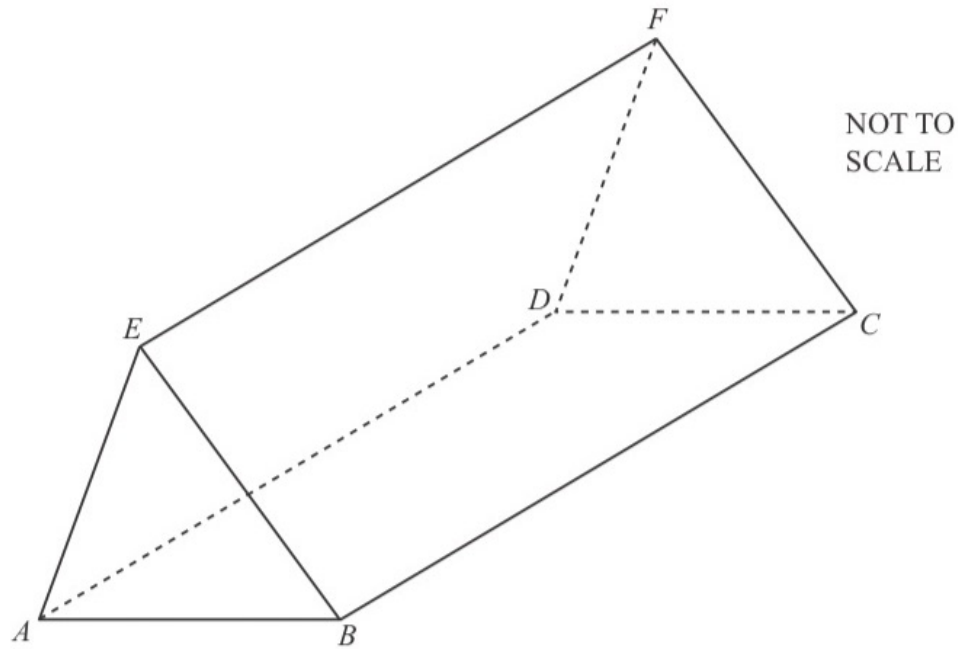

The diagram shows a solid triangular prism  $ABCDEF$  of length 15 cm.  
 $AB = 6.4$  cm,  $EB = 5.7$  cm and the volume of the prism is  $145 \text{ cm}^3$ .

(a) Show that angle  $EBA = 32^\circ$ , correct to the nearest degree.

(b) Find the length of  $EA$ .

..... cm [3]

[3]

Q18.

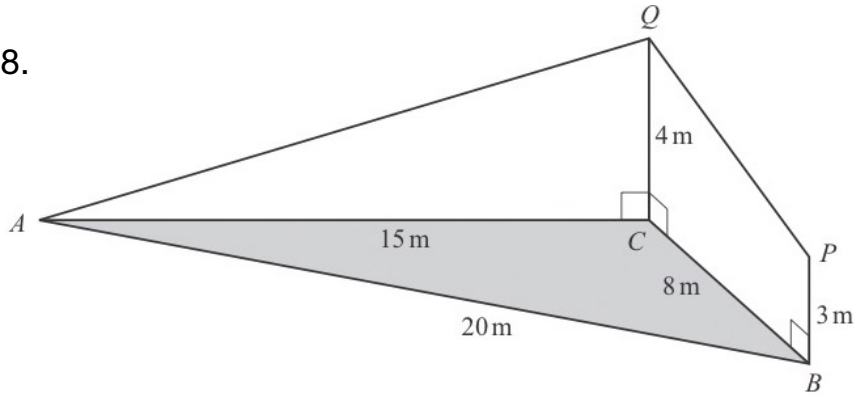

The diagram shows triangle  $ABC$  on horizontal ground.  
 $AC = 15\text{ m}$ ,  $BC = 8\text{ m}$  and  $AB = 20\text{ m}$ .

$BP$  and  $CQ$  are vertical poles of different heights.  
 $BP = 3\text{ m}$  and  $CQ = 4\text{ m}$ .  
 $AQ$  and  $PQ$  are straight wires.

(a) Show that angle  $ACB = 117.5^\circ$ , correct to 1 decimal place.

[4]

(b) Calculate the area of triangle  $ABC$ .

.....  $\text{m}^2$  [2]

(c) Calculate the length of  $AQ$ .

..... m [2]

(d) Calculate the angle of elevation of  $Q$  from  $P$ .

..... [3]

(e) Another straight wire connects  $A$  to the midpoint of  $PQ$ .

Calculate the angle between this wire and the horizontal ground.

Q19.

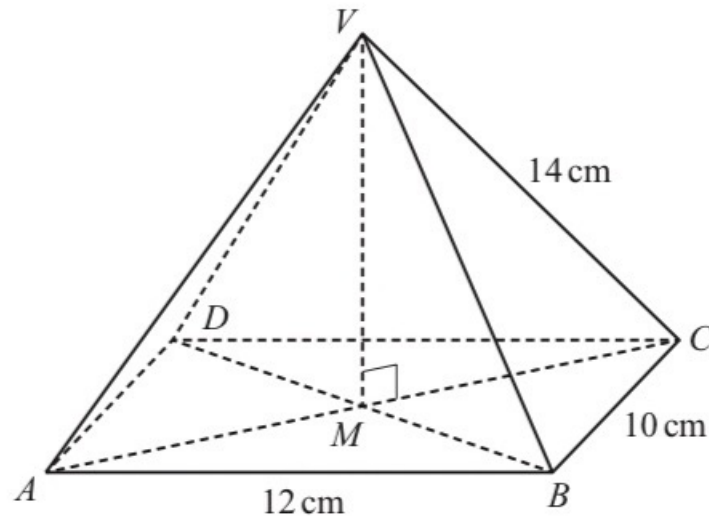

NOT TO  
SCALE

The diagram shows a pyramid  $VABCD$  with a rectangular base.  
 $V$  is vertically above  $M$ , the intersection of the diagonals  $AC$  and  $BD$ .  
 $AB = 12$  cm,  $BC = 10$  cm and  $VC = 14$  cm.

Calculate the angle that  $VC$  makes with the base  $ABCD$ .

..... [4]

Q20.

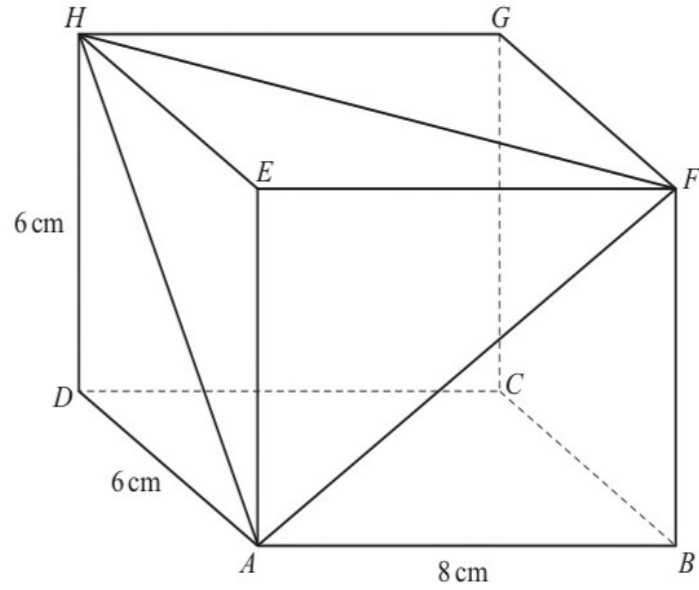

NOT TO  
SCALE

The diagram shows a cuboid.  
 $AB = 8\text{ cm}$ ,  $AD = 6\text{ cm}$  and  $DH = 6\text{ cm}$ .

Calculate angle  $HAF$ .

Angle  $HAF = \dots\dots\dots$  [6]

# Compound measurements and Travel time graphs



By .... Kru ชี

**A compound measure is made up of two or more different measurements**

- Speed
- Density
- Force

Speed is a compound measure because  $\text{speed} = \frac{\text{distance}}{\text{time}}$

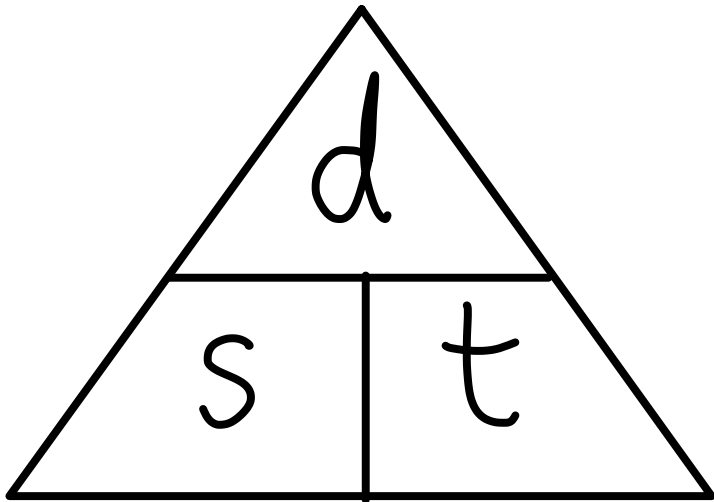

**Density is the mass of a substance contained in a certain volumes**

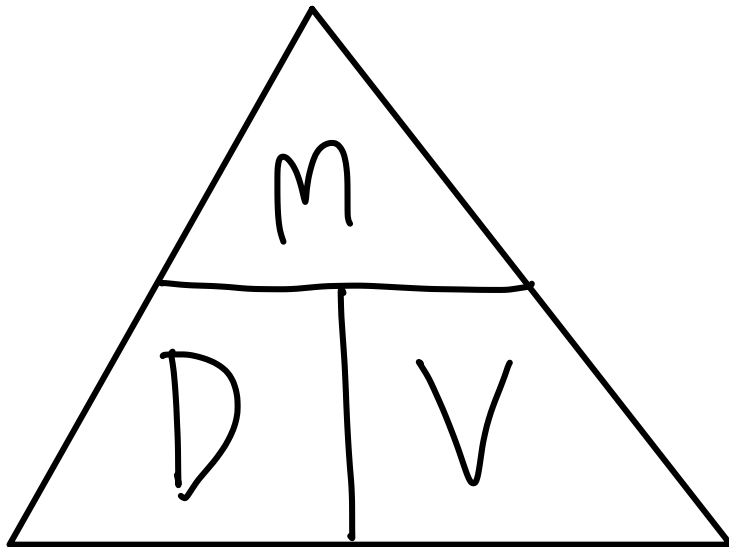

**Pressure is the force applied over a certain area**

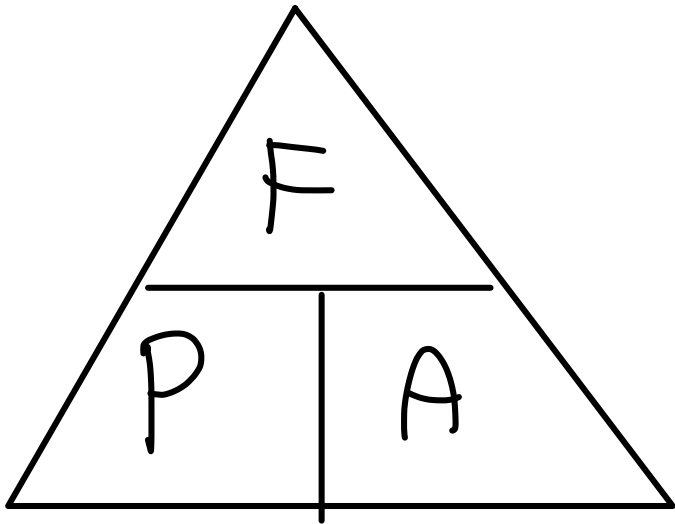

Q1. Change 2.15 hours into minutes.

..... min [1]

Q2. A stone has volume  $45 \text{ cm}^3$  and mass 126 g.  
Find the density of the stone, giving the units of your answer.

[Density = mass  $\div$  volume]

..... [2]

Q3. A box is a cuboid with length 45 cm, width 30 cm and height 42 cm.  
The box is completely filled with 90.72 kg of sand.

Calculate the density of this sand in  $\text{kg/m}^3$ .

[Density = mass  $\div$  volume]

.....  $\text{kg/m}^3$  [3]

Q4. A train of length 105 m takes 11 seconds to pass completely through a station of length 225 m.  
Calculate the speed of the train in km/h.

..... km/h [3]

Q5. A train passes through a station at a speed of 108 km/h.  
The length of the station is 120 m.  
The train takes 7 seconds to completely pass through the station.  
Work out the length of the train.

..... m [3]

Q6.

A train travels between two stations.

The distance between the stations is 220 km, correct to the nearest kilometre.

The speed of the train is 125 km/h, correct to the nearest 5 km/h.

Calculate the upper bound for the time the journey takes.

Give your answer in hours and minutes.

..... h ..... min [4]

Q7.

The distance–time graph shows information about Kai’s journey from home to the office.

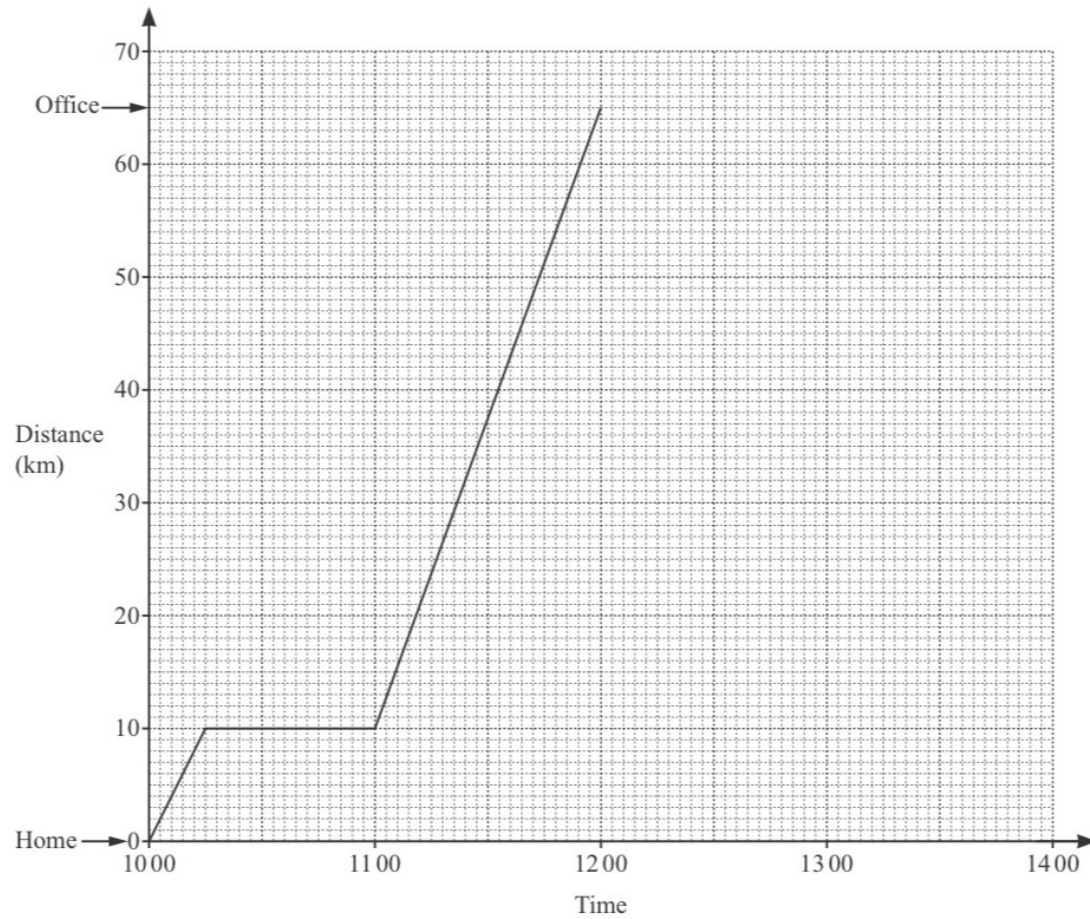

(a) Calculate the average speed, in km/h, for Kai’s journey from home to the office.

..... km/h [2]

(b) When Kai arrives at the office, he finds his meeting is cancelled. He immediately returns home at a constant speed of 50 km/h.

Complete the distance–time graph to show his journey home. [1]

Q8.

A car starts its journey by accelerating from rest at a constant rate of  $0.7 \text{ m/s}^2$  for 20 seconds, before reaching a constant speed of  $14 \text{ m/s}$ .

It then travels at  $14 \text{ m/s}$  for a distance of  $210 \text{ m}$ .

The car then decelerates at a constant rate of  $1.4 \text{ m/s}^2$ , before coming to a stop.

On the grid, complete the speed–time graph for the car’s journey.

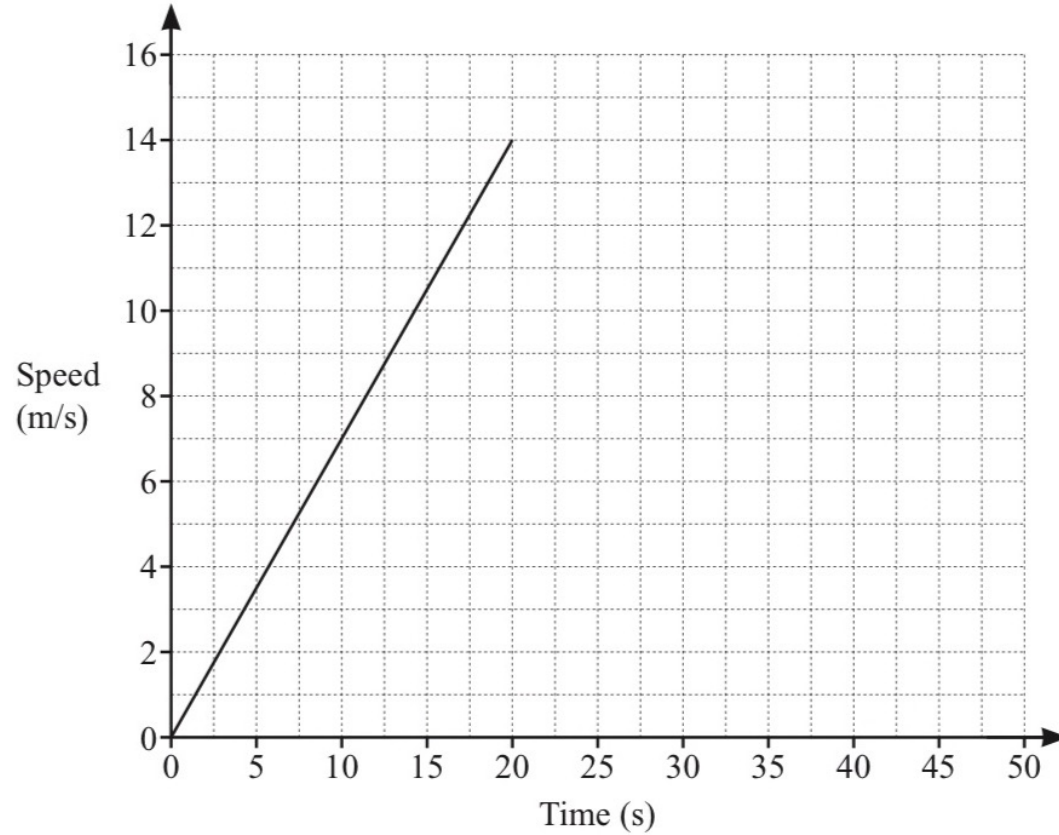

[3]

Q9.

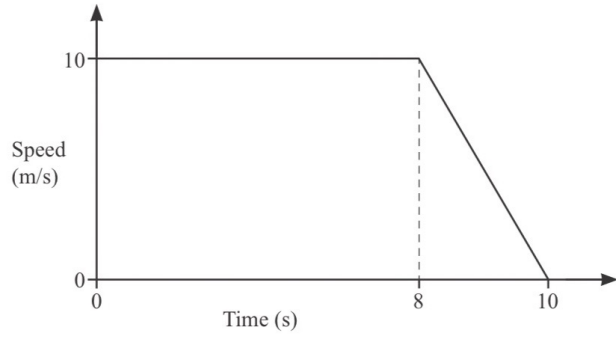

NOT TO SCALE

The diagram shows the speed–time graph for part of a car journey.  
 Calculate the total distance travelled during the 10 seconds.

..... m [2]

Q10.



NOT TO SCALE

The diagram shows the speed–time graph for 24 seconds of a car journey.

Calculate

(a) the deceleration of the car in the final 8 seconds,

..... m/s<sup>2</sup> [1]

(b) the total distance travelled during the 24 seconds.

..... m [2]

Q11.

The diagram shows the speed–time graph for part of the journey of a car.



The car starts from rest and accelerates at a uniform rate for 15 seconds before reaching a constant speed of 30 m/s.

(a) Calculate the acceleration for the first 15 seconds.

.....  $\text{m/s}^2$  [1]

(b) After  $T$  minutes, the total distance travelled is 45 kilometres.

Find the value of  $T$ .

$T =$  ..... min [4]

**Q12.**

(a) The diagram shows the speed–time graph for part of a journey for two vehicles, a car and a bus.

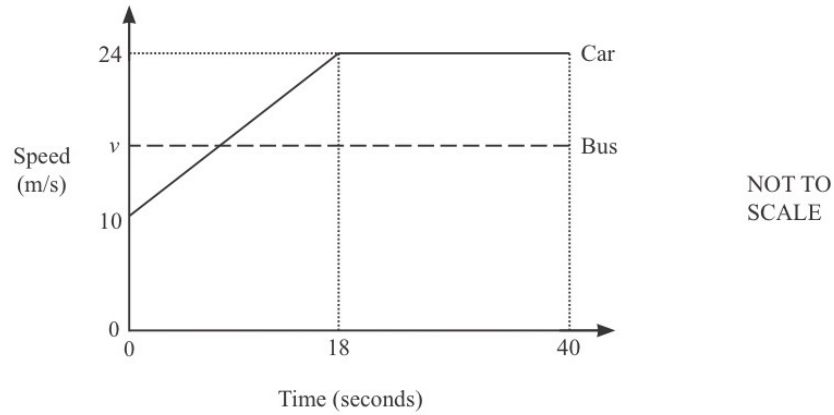

(i) Calculate the acceleration of the car during the first 18 seconds.

.....  $\text{m/s}^2$  [1]

(ii) In the first 40 seconds the car travelled 134m more than the bus.

Calculate the constant speed,  $v$ , of the bus.

$v =$  .....  $\text{m/s}$  [4]

(b) A train takes 10 minutes 30 seconds to travel 16240m.

Calculate the average speed of the train.  
Give your answer in kilometres per hour.

.....  $\text{km/h}$  [3]

Q13.

Abdul draws this speed–time graph for a journey.  
The graph has four sections A, B, C and D.

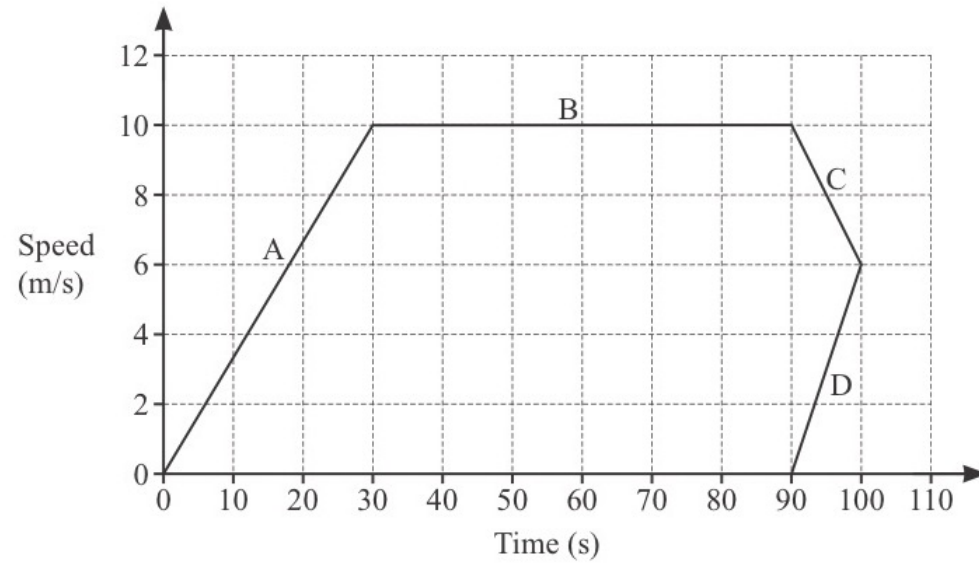

Complete these statements about the speed–time graph.

Section ..... cannot be correct.

Section ..... shows constant speed.

Section ..... shows deceleration.

Section A shows acceleration of .....  $\text{m/s}^2$ .

The distance travelled in the first 30 seconds of the journey is ..... m.

[4]

# Symmetry



By .... Kru ชี

## What is symmetry?

- **Symmetry** in mathematics can refer to one of two types:
  - **Line symmetry** which deals with **reflections** and **mirror images** of shapes or parts of shapes
  - Rotational symmetry which deals with how often a shape looks identical (**congruent**) when it has been rotated



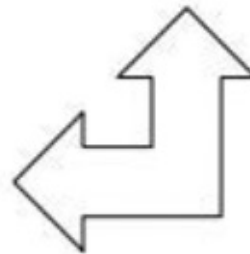
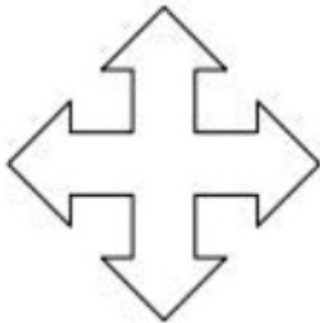
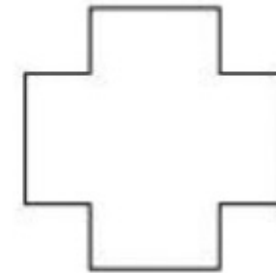
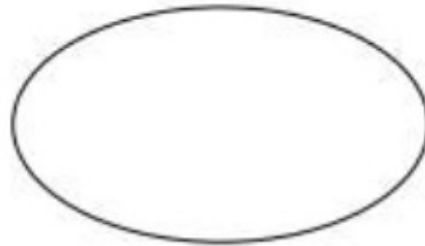
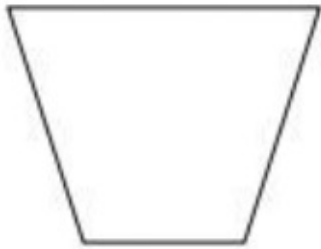

## What is line symmetry?

- **Line symmetry** refers to shapes that can have **mirror** lines added to them
  - Each side of the line of symmetry is a **reflection** of the other side
- Lines of symmetry can be thought of as a **folding** line too
  - **Folding** a shape along a line of symmetry results in the two parts sitting **exactly** on top of each other

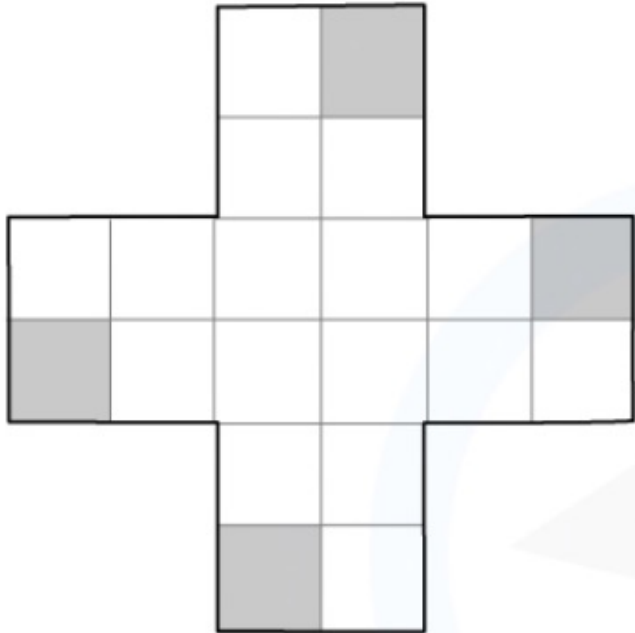

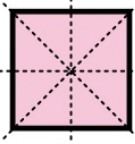
# Draw line of symmetry

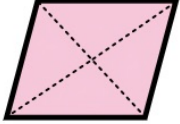
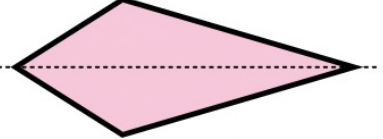
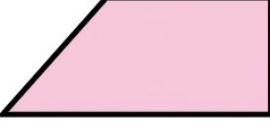

Quadrilateral	Image	Number of Lines of Symmetry
Square		4
Rectangle		2
Parallelogram		0
Rhombus		2
Kite		1
Trapezium		0
Isosceles Trapezium		1

# Lines of symmetry in regular polygons

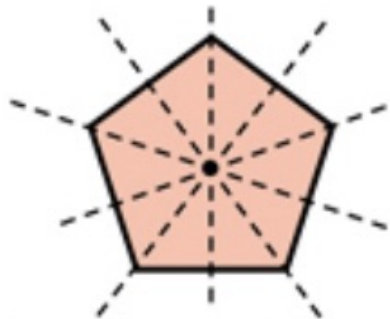

**Regular Pentagon**  
Five lines of Symmetry

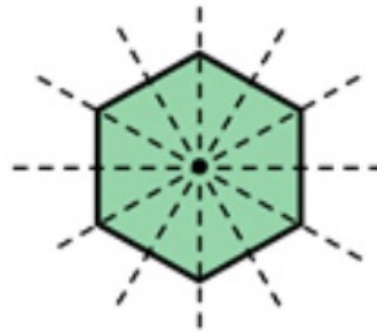

**Regular Hexagon**  
Six lines of Symmetry

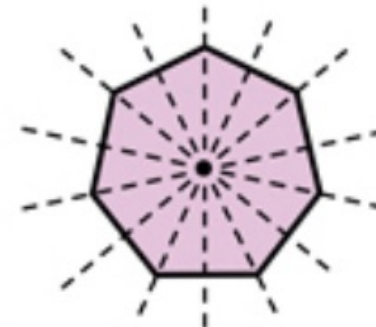

**Regular Heptagon**  
Seven lines of Symmetry

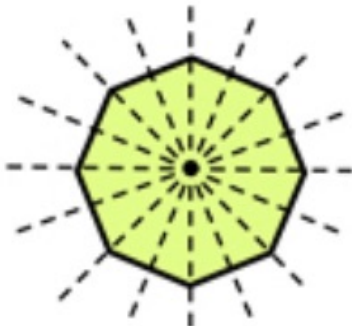

**Regular Octagon**  
Eight lines of Symmetry

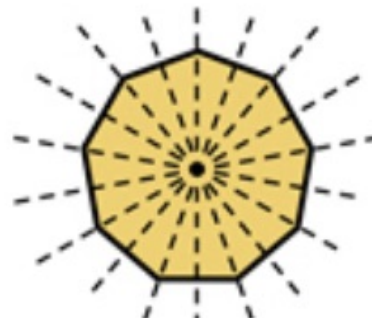

**Regular Nonagon**  
Nine lines of Symmetry

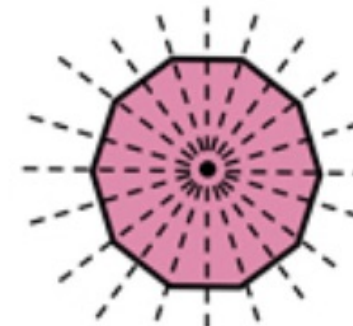

**Regular Decagon**  
Ten lines of Symmetry

## Question 1

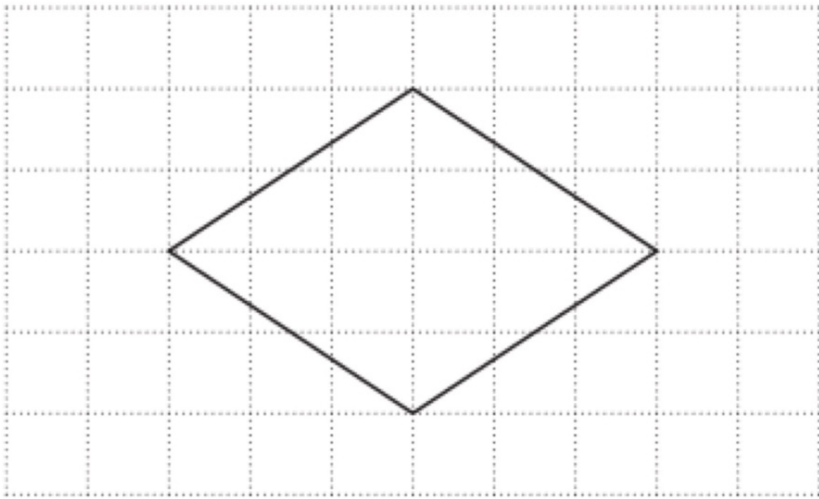

A shape is drawn on a one-centimetre grid.

How many lines of symmetry does the shape have?

## Question 2

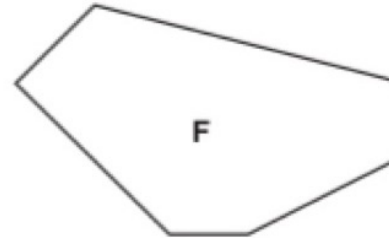
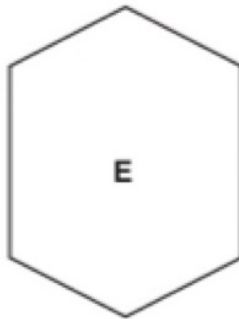
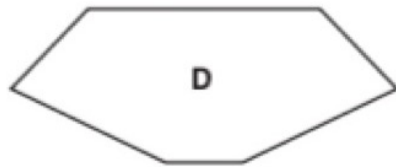
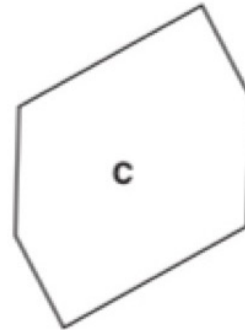
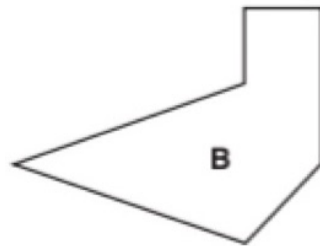
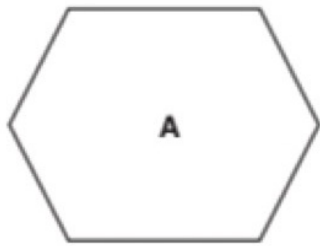

Which hexagon has **just one** line of symmetry?

## Question 3

The diagrams show patterns made from grey tiles and white tiles.

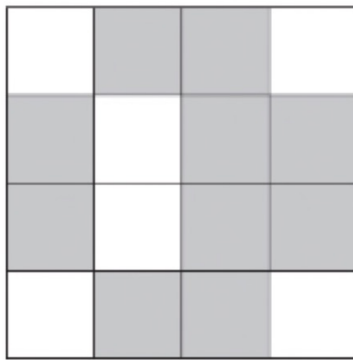

A

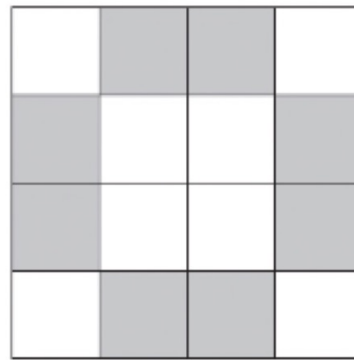

B

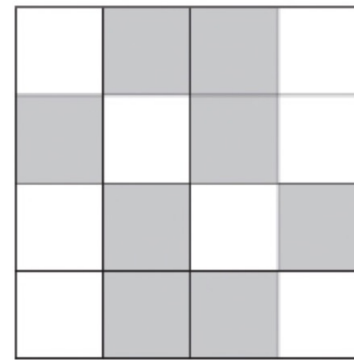

C

One of the patterns has exactly 1 line of symmetry.  
Write down the letter of this pattern.

## Question 4

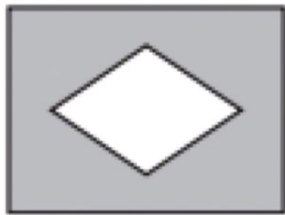

*A*

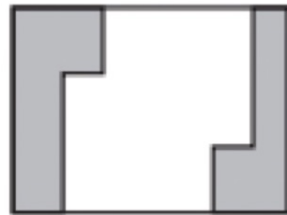

*B*



*C*



*D*

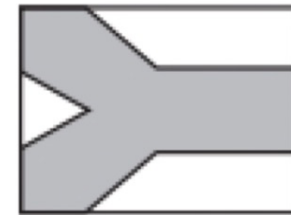

*E*

Which **three** flags have line symmetry?

# What is rotational symmetry ?

**Rotational symmetry** is the number of times a shape can “fit into itself” when it is rotated **360** degrees about its centre.

To calculate the order of rotational symmetry of a shape, you need to locate the centre of the shape.

If the polygon has an even number of sides, this can be done by joining the diagonals. If the polygon has an odd number of sides, this can be done by joining each vertex to the midpoint of the opposing side.

You then rotate the shape **360** degrees around the centre and see how many times the shape looks exactly like the original.



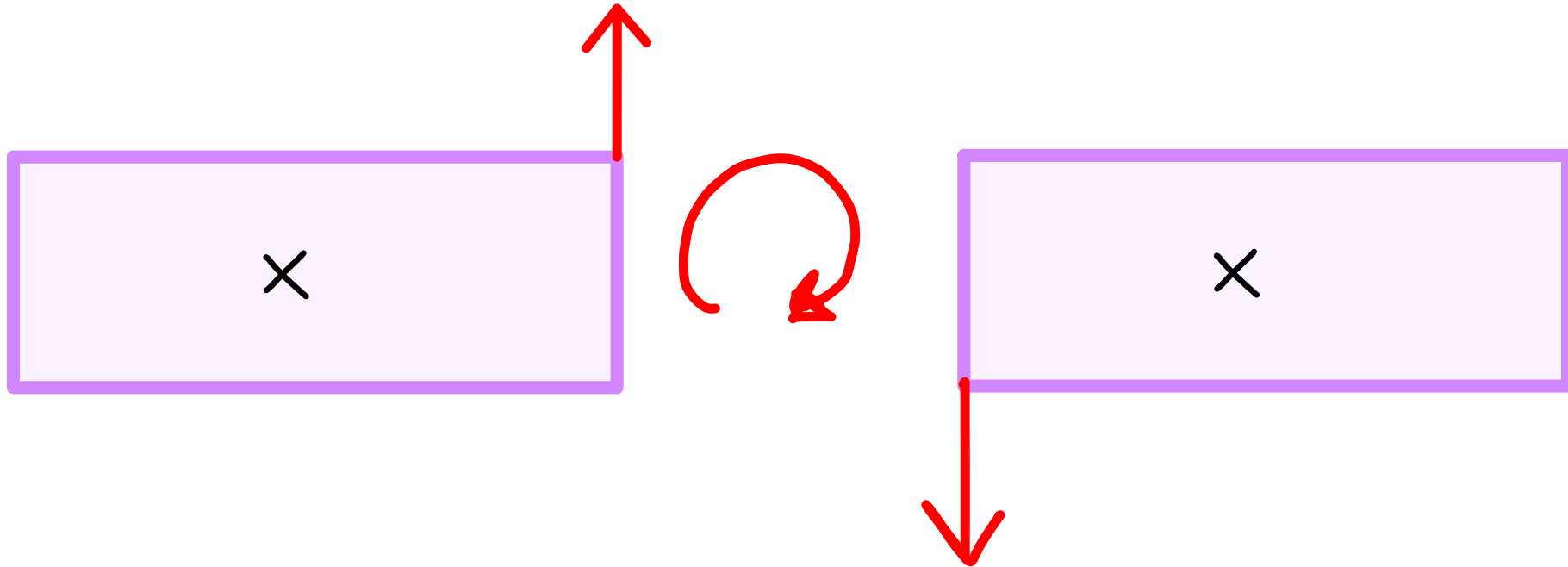

# Rectangle

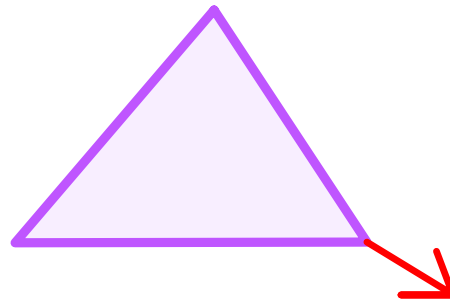
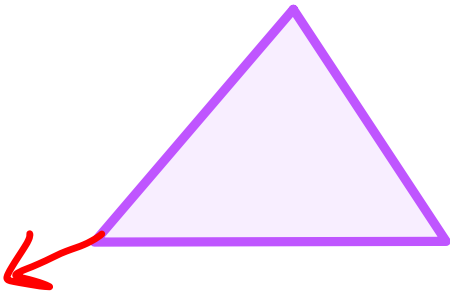
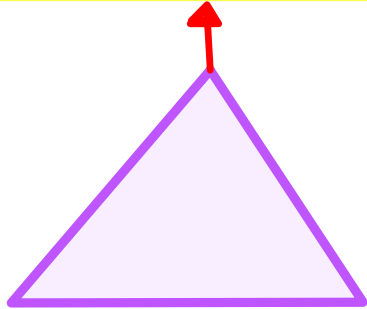

# Order 2

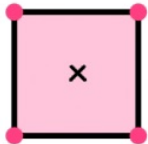
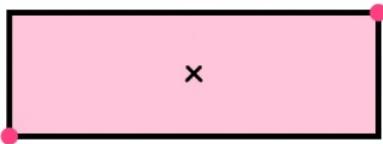
**Equilateral Triangle**

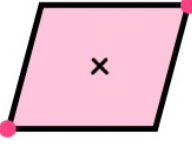
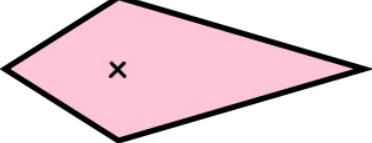
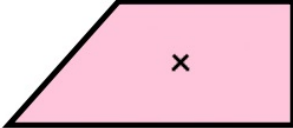

Quadrilateral	Image	Order of Rotational Symmetry
Square		4
Rectangle		2
Parallelogram		2
Rhombus		2
Kite		0
Trapezium		0
Isosceles Trapezium		0

# Rotational symmetry in regular polygons

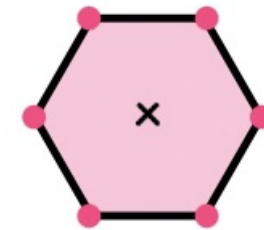
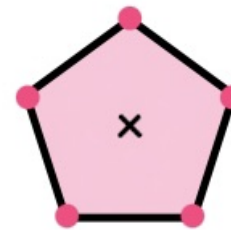
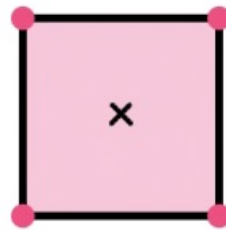
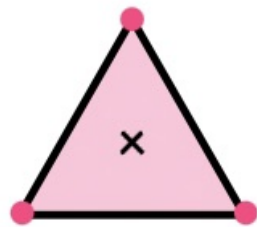

2D Polygon	Equilateral Triangle	Square	Regular Pentagon	Regular Hexagon
Order of Rotational Symmetry	3	4	5	6

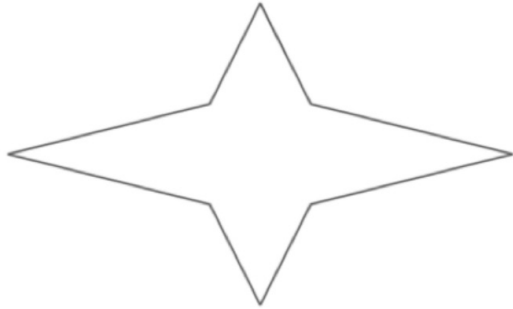

Lines of symmetry \_\_\_\_\_

Rotational symmetry order \_\_\_\_\_



Lines of symmetry \_\_\_\_\_

Rotational symmetry order \_\_\_\_\_



Lines of symmetry \_\_\_\_\_

Rotational symmetry order \_\_\_\_\_



Lines of symmetry \_\_\_\_\_

Rotational symmetry order \_\_\_\_\_



Lines of symmetry \_\_\_\_\_

Rotational symmetry order \_\_\_\_\_



Lines of symmetry \_\_\_\_\_

Rotational symmetry order \_\_\_\_\_



Lines of symmetry \_\_\_\_\_

Rotational symmetry order \_\_\_\_\_



Lines of symmetry \_\_\_\_\_

Rotational symmetry order \_\_\_\_\_

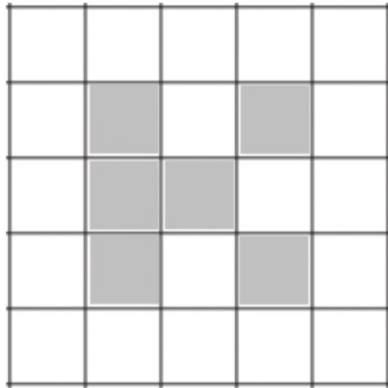

Shade one more square to make a pattern with 1 line of symmetry.

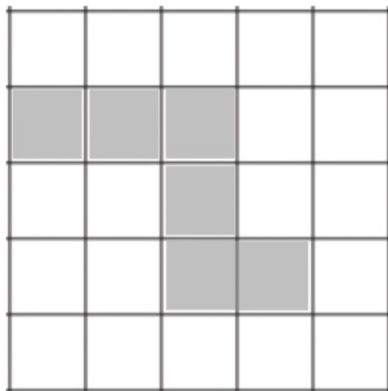

Shade one more square to make a pattern with rotational symmetry order 2.

Q1.

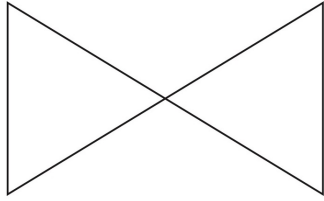

(a) Complete this statement.

The diagram has rotational symmetry of order .....

(b) On the diagram, draw all the lines of symmetry.

Q2.

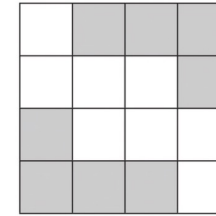

Write down the order of rotational symmetry of the diagram.

[1]

[2]

..... [1]

Q3.

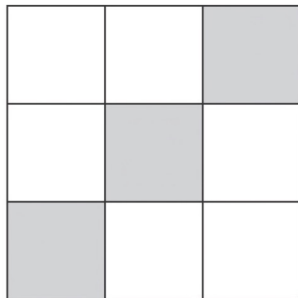

(a) Complete the statement.

The diagram has rotational symmetry of order .....

[1]

(b) On the diagram, draw all the lines of symmetry.

[2]

# Construction



By .... Kru ชี



## For construction

- Ruler
- Pencil
- Compass
- Protractor

- Constructions are accurate drawings of shapes, angles and lines in geometry

# 1. Perpendicular bisector of a line



## 2. Perpendicular from given point to a line

Point is outside a line

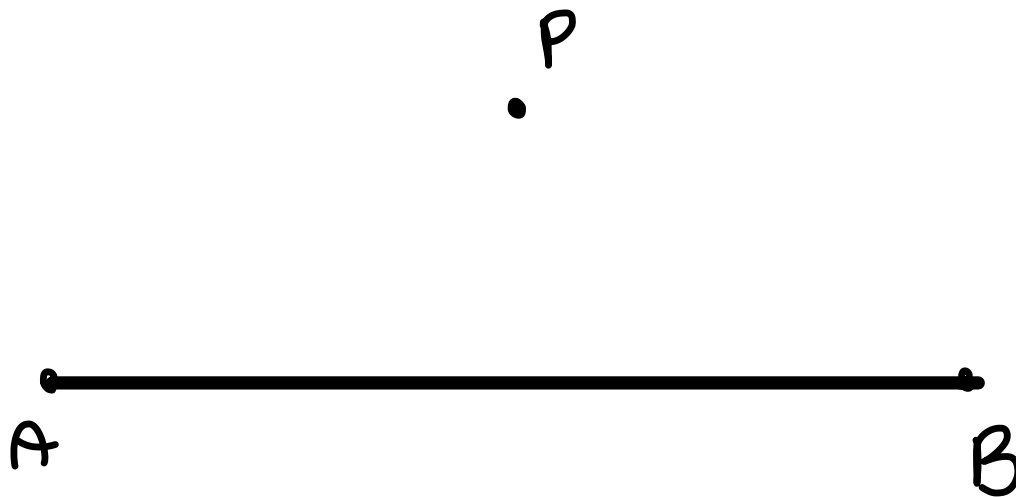

## 2. Perpendicular from given point to a line

Point is on a line

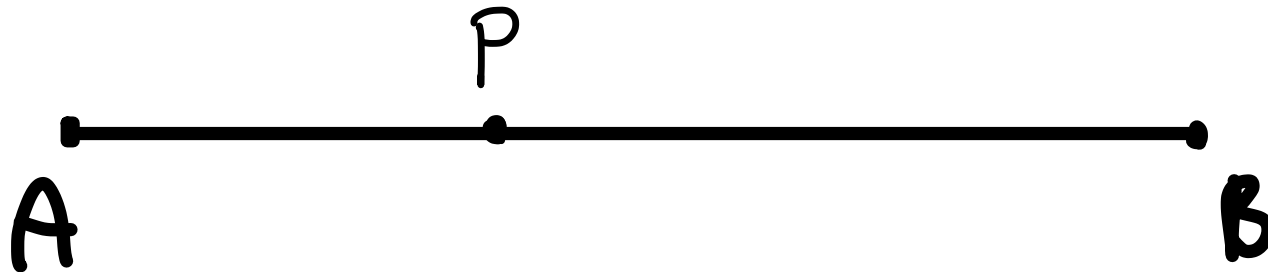

### 3. Bisector of angle

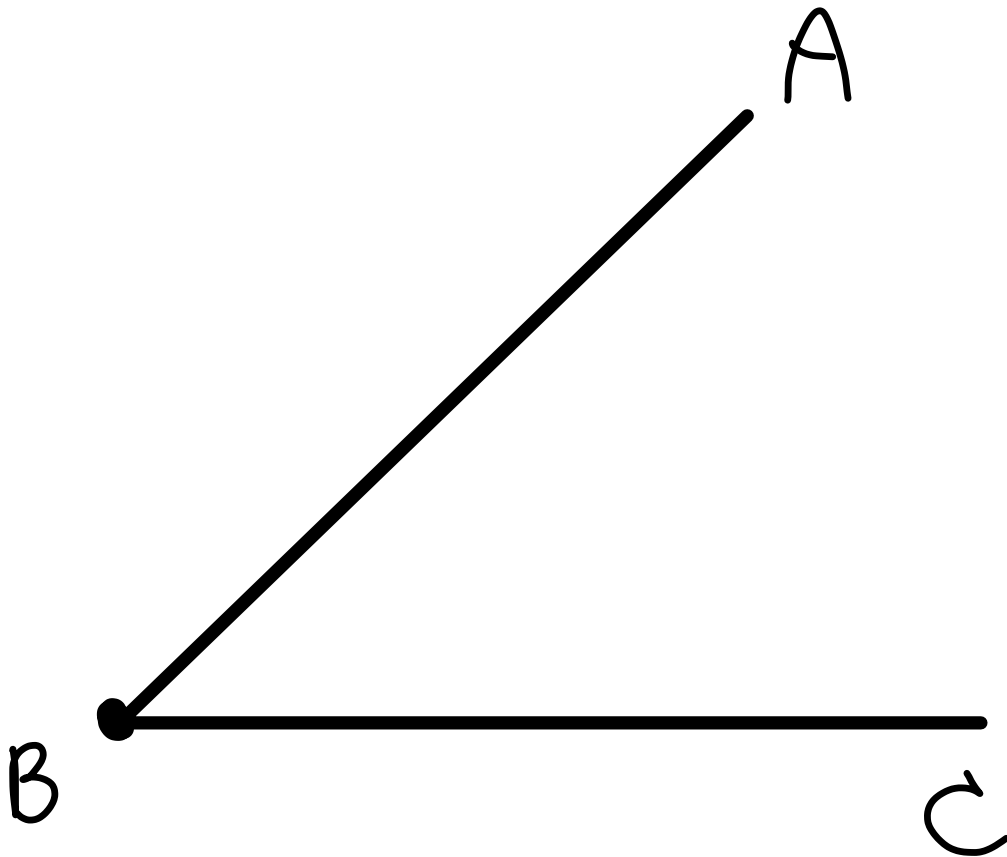

## 4. Equilateral triangle

Example : Draw equilateral triangle with each side is 6 cm

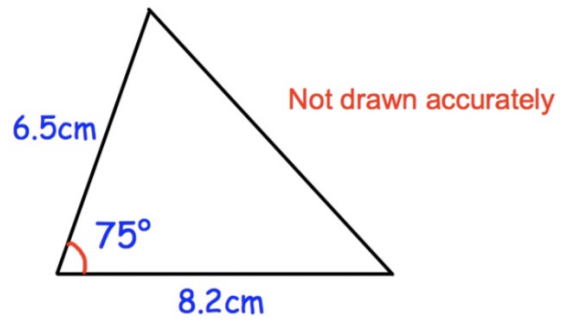

Make an accurate drawing of the triangle

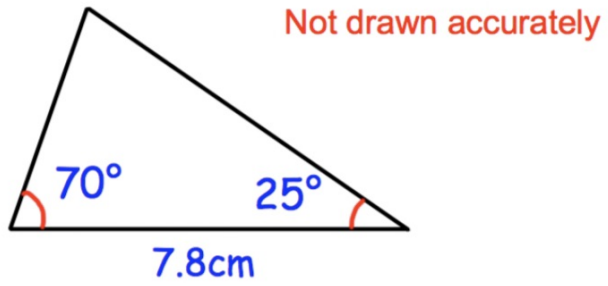

Make an accurate drawing of the triangle

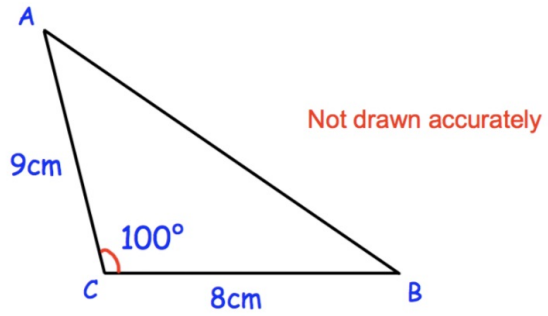

Make an accurate drawing of ABC

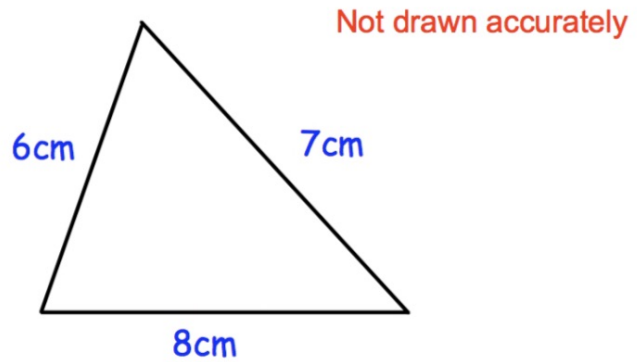

Accurately construct the triangle

A rhombus has side length 6.5 cm.  
The rhombus can be constructed by drawing two triangles.

**Using a ruler and compasses only**, construct the rhombus.  
Leave in your construction arcs.  
One diagonal of the rhombus has been drawn for you.

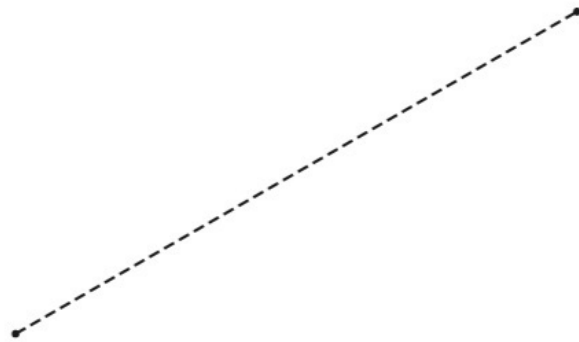

[2]

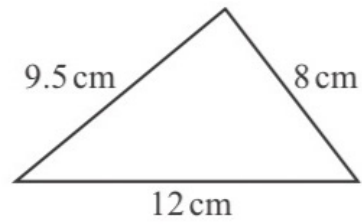

NOT TO  
SCALE

**Using a ruler and compasses only**, construct this triangle.  
Leave in your construction arcs.

[2]

# Transformation



By .... Kru ชี

# Types of transformations

1. Translation

2. Reflection

3. Rotation

4. Enlargement ( positive & negative scale factor )

# Translation

translation: 5 units right and 1 unit up

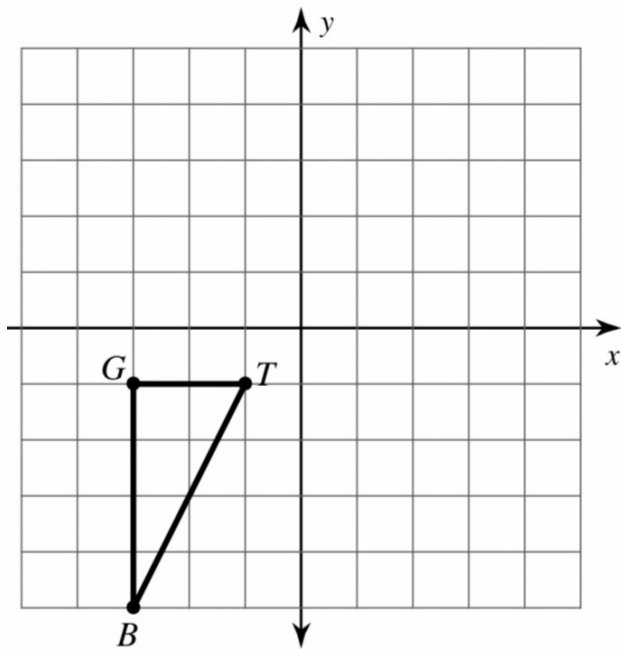

Describe the transformation of the black shape to its image ( blue shape )

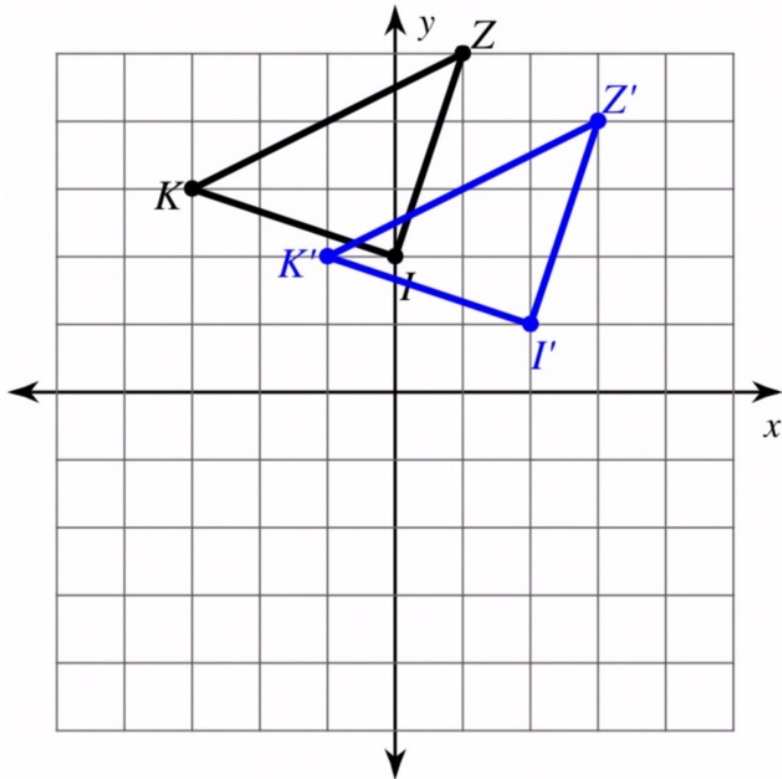

# Describe translation by column vectors

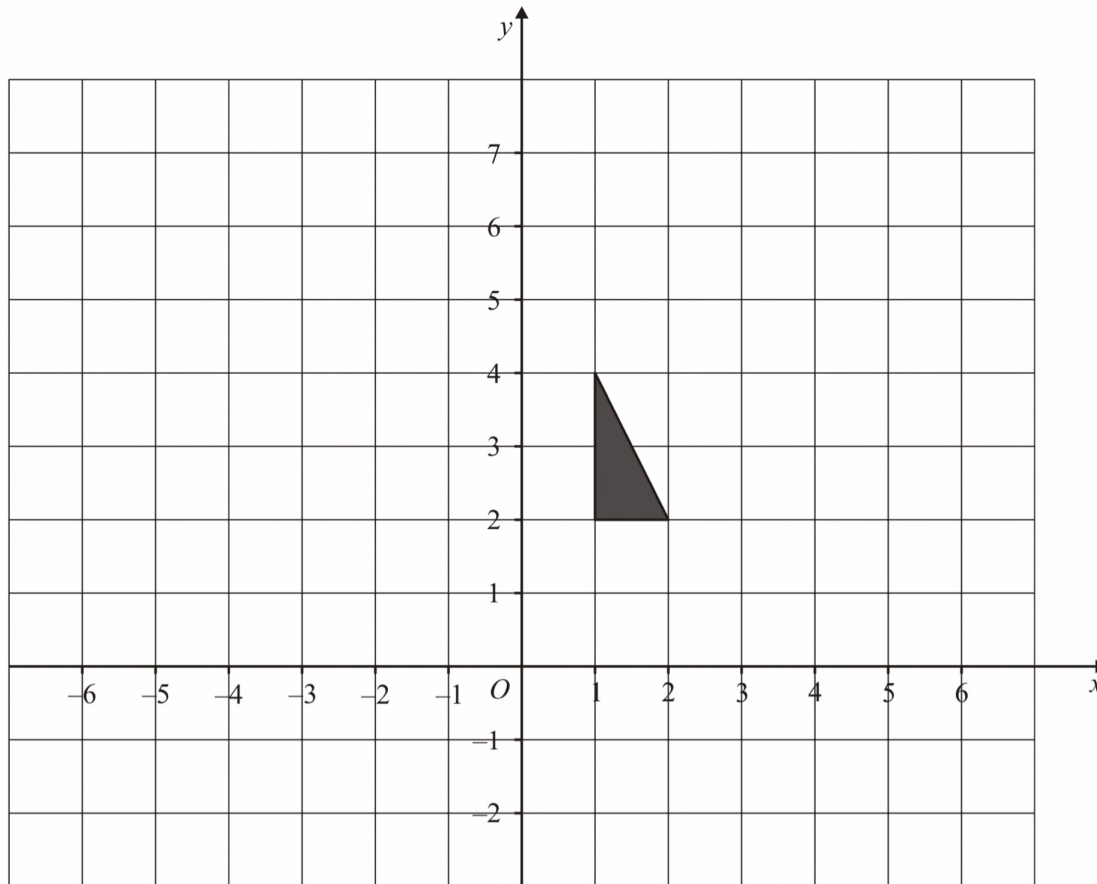

Translate this shape by vector  $\begin{pmatrix} -5 \\ 2 \end{pmatrix}$

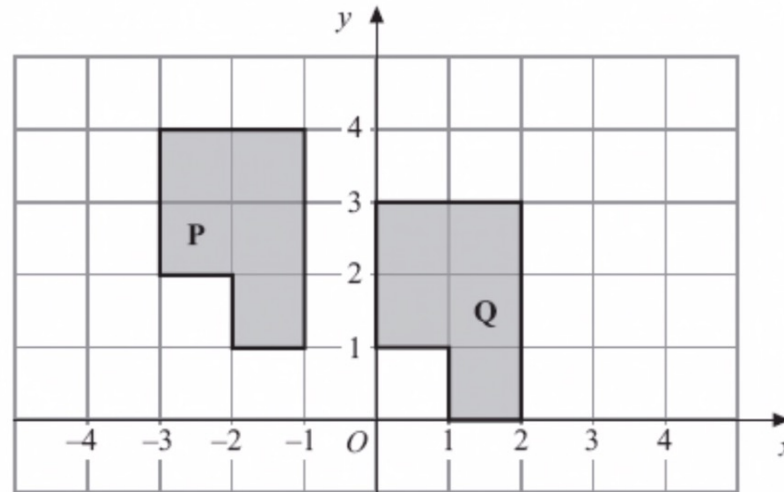

Describe fully the single transformation that will map shape **P** onto shape **Q**.

# Reflection

**Reflection** is a type of transformation that flips a shape in a mirror line (also called a line of reflection) so that each point is the same distance from the mirror line as its reflected point.

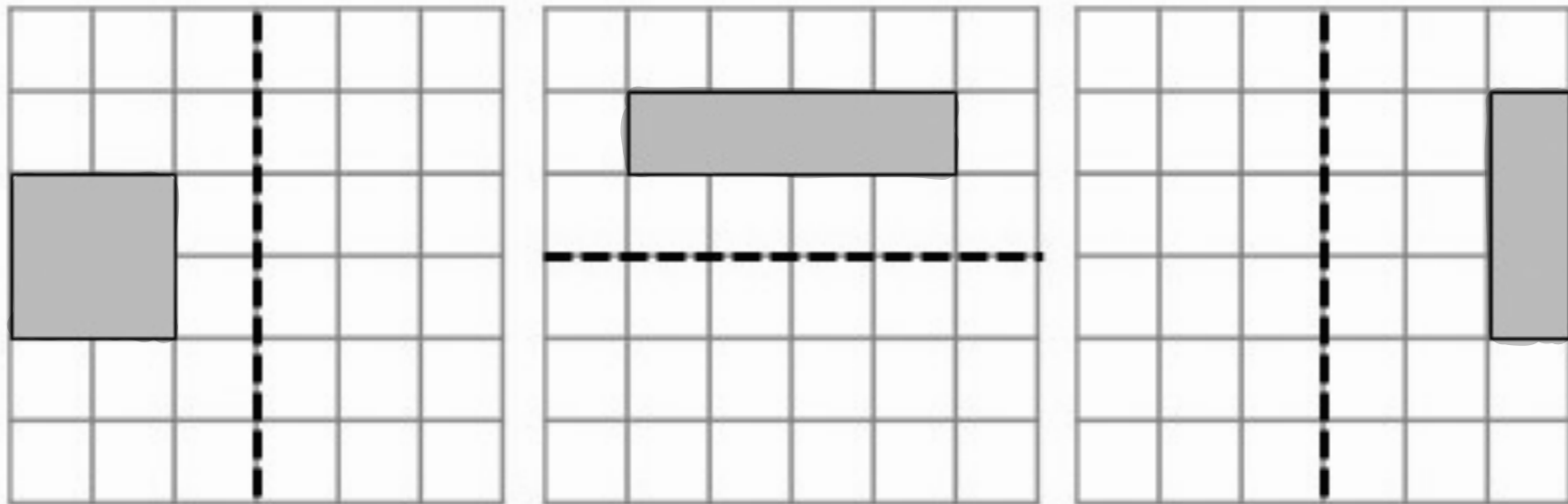

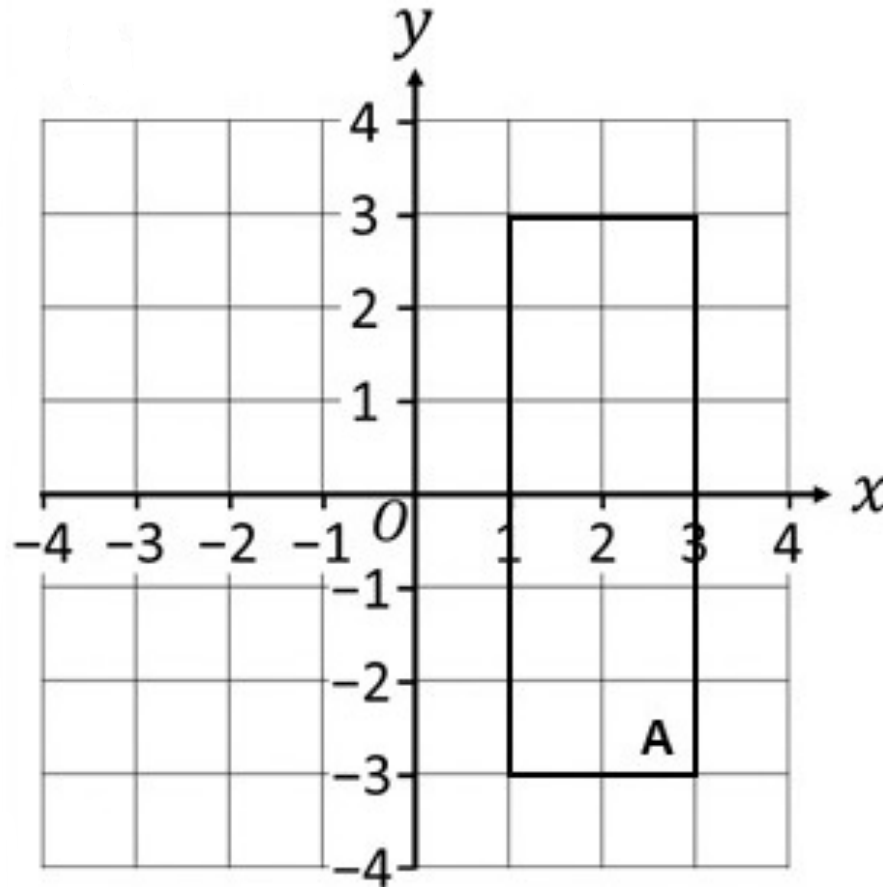

Reflect Shape **A** in the  $y$  axis.

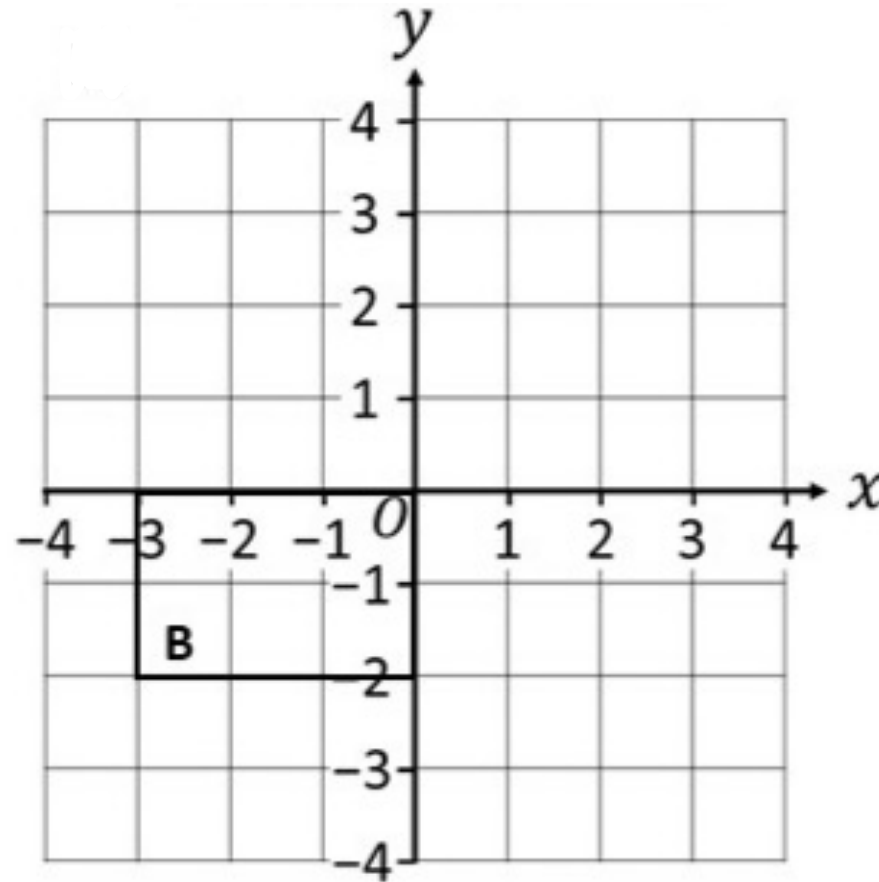

Reflect Shape **B** in the line  $y = 1$

## Reflection: Across Line $y = x$

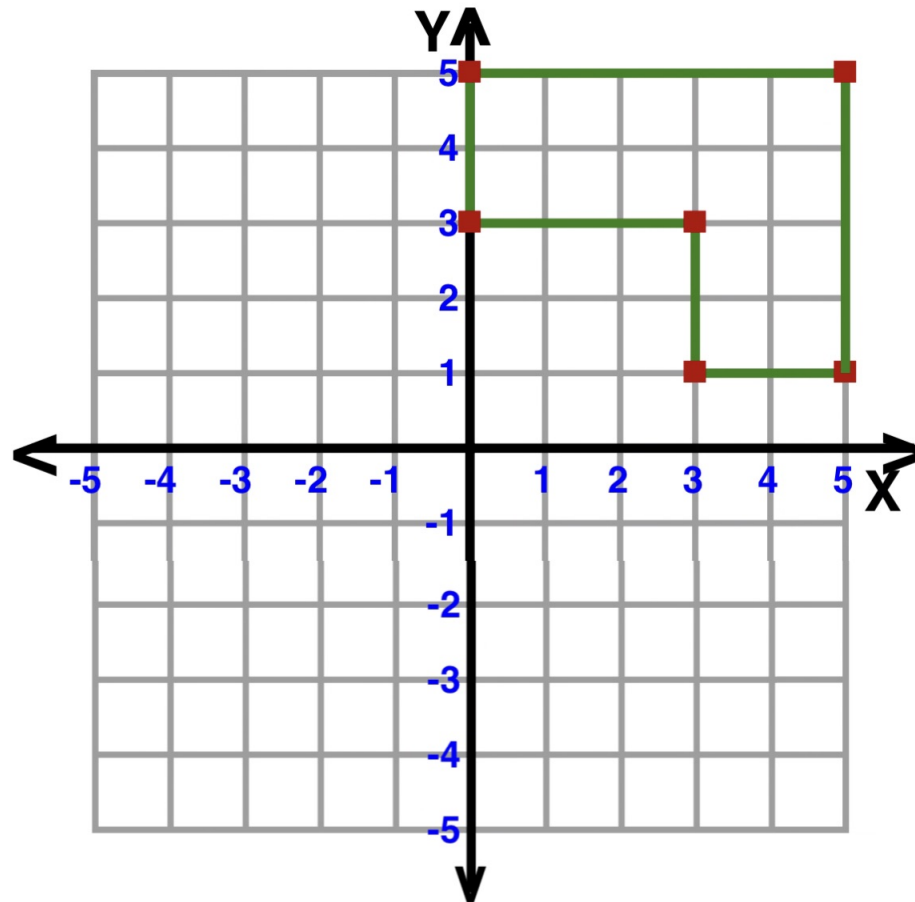

## Reflection: Across Line $y = -x$

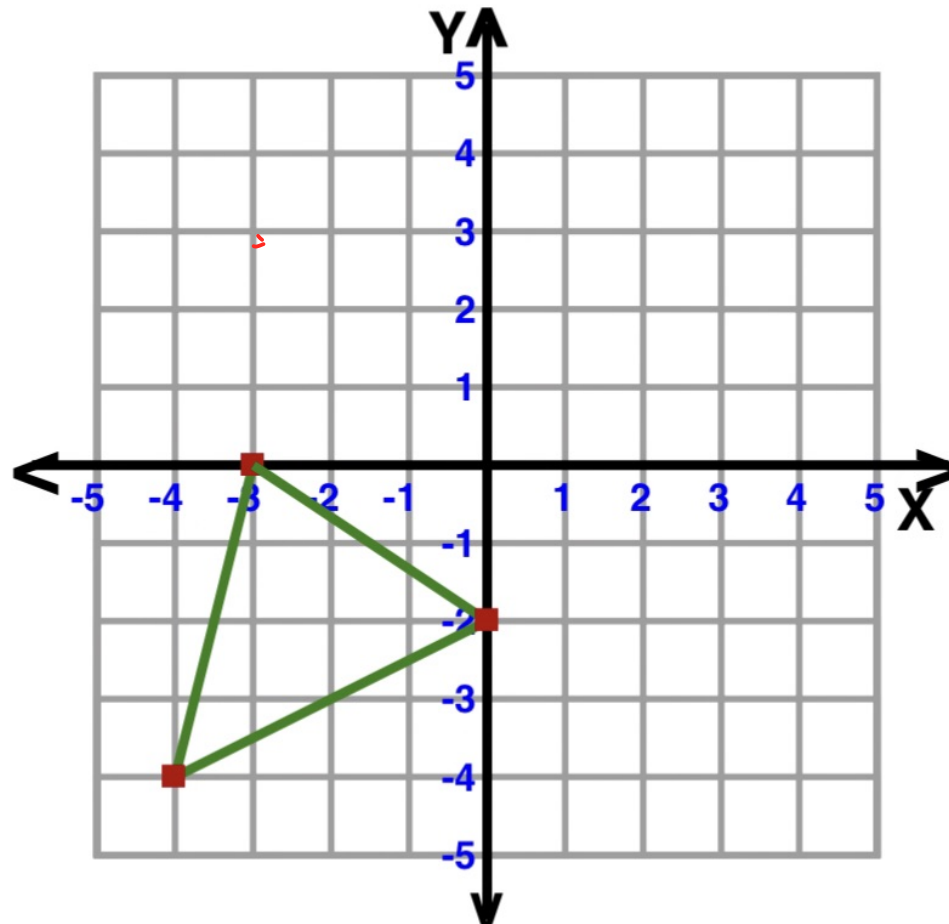

# Rotation

Rotation is transformation that turn a shape around a fixed point

To rotation a shape we need

1. A centre of rotation
2. An angle of rotation
3. The direction of rotation



Clockwise



Anti-clockwise

## Clockwise

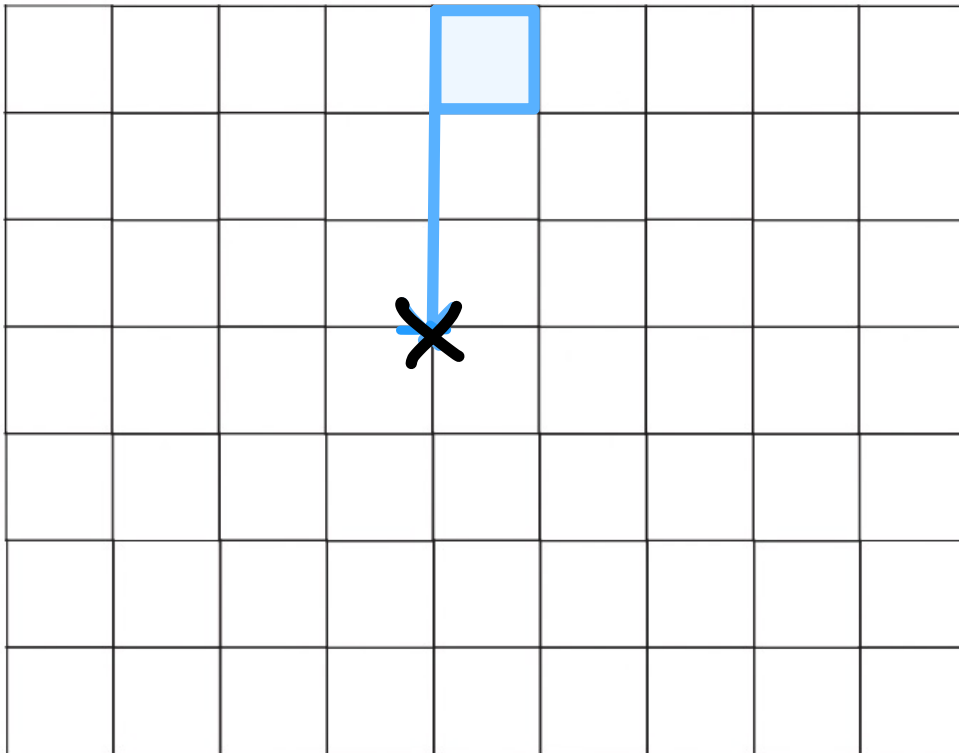

## Anti-clockwise

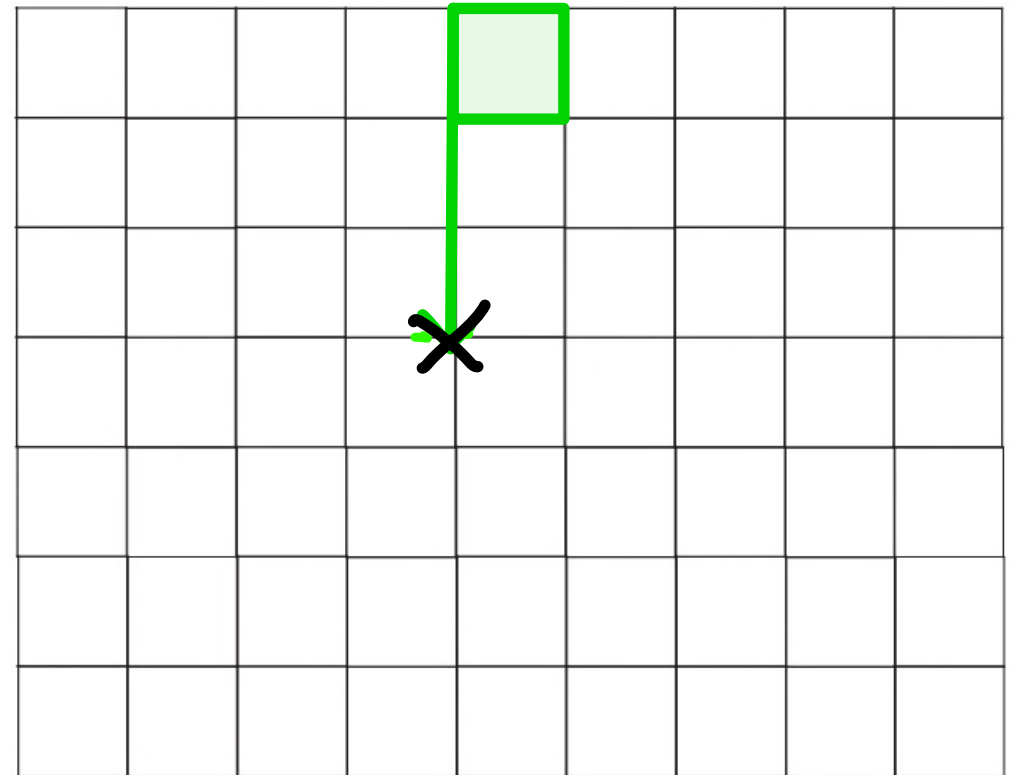

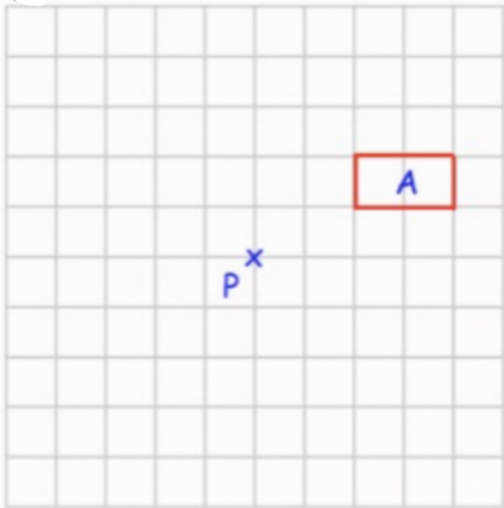

rotate  $90^\circ$  clockwise about P

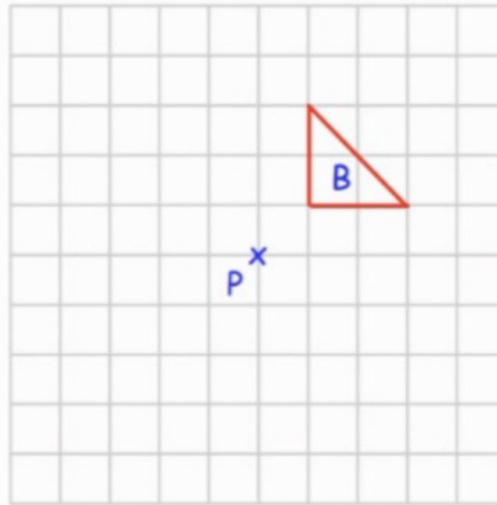

rotate  $90^\circ$  anticlockwise about P

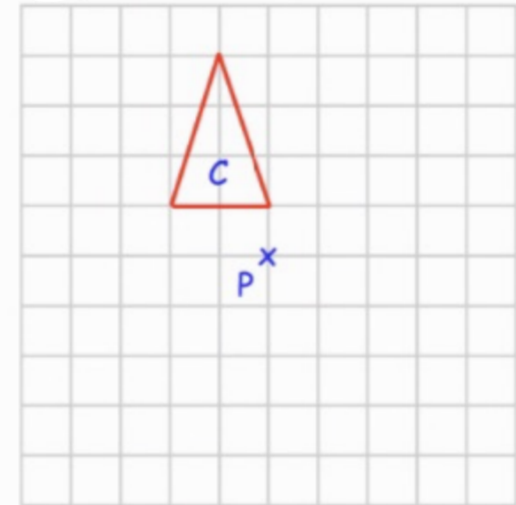

rotate  $90^\circ$  clockwise about P

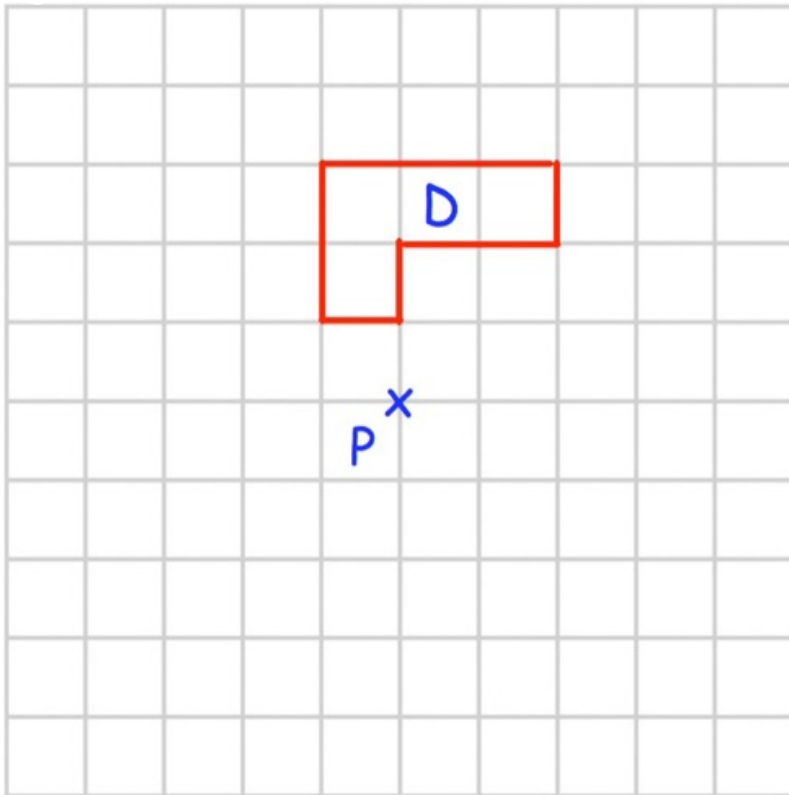

rotate  $180^\circ$  about P

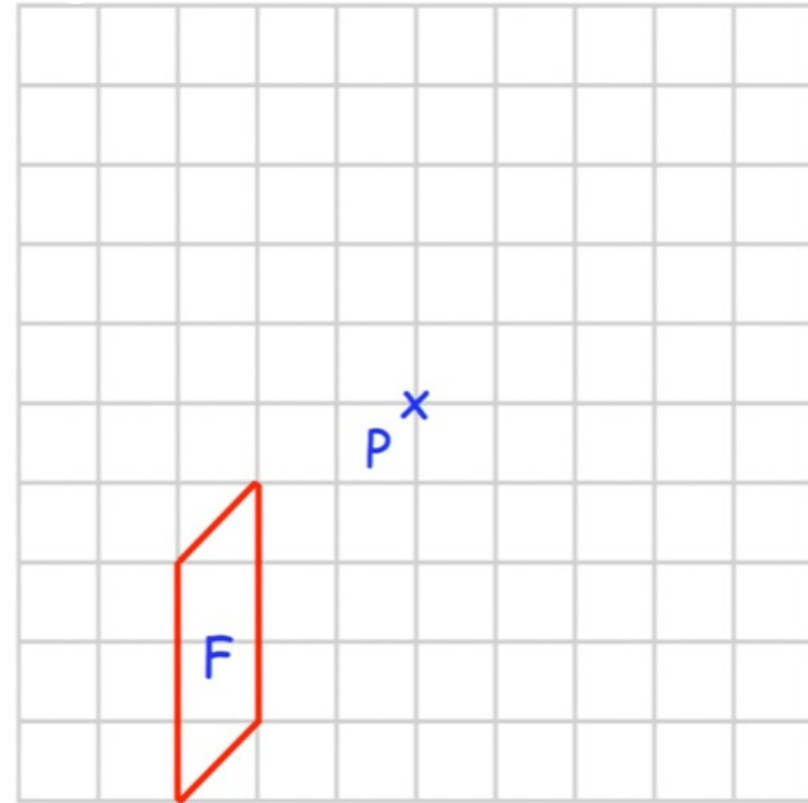

rotate  $180^\circ$  about P

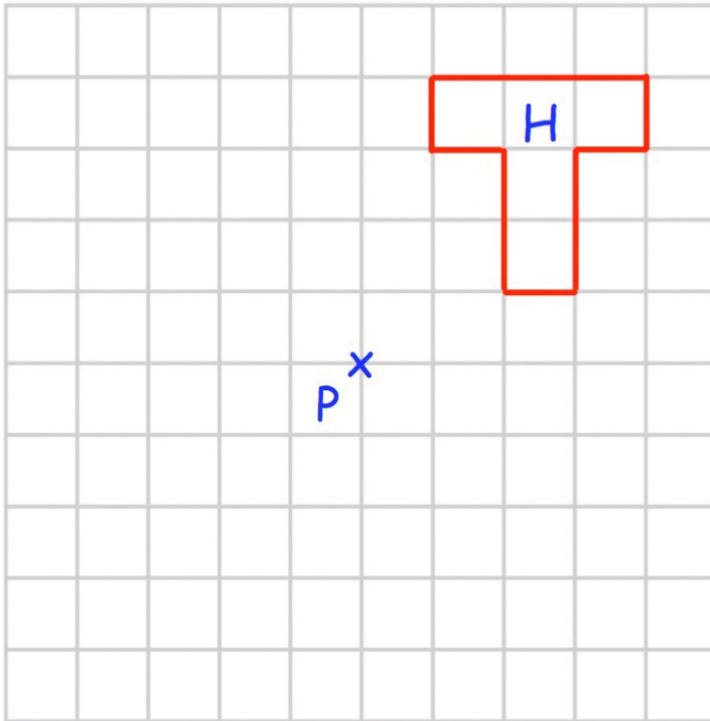

rotate  $270^\circ$  clockwise about P

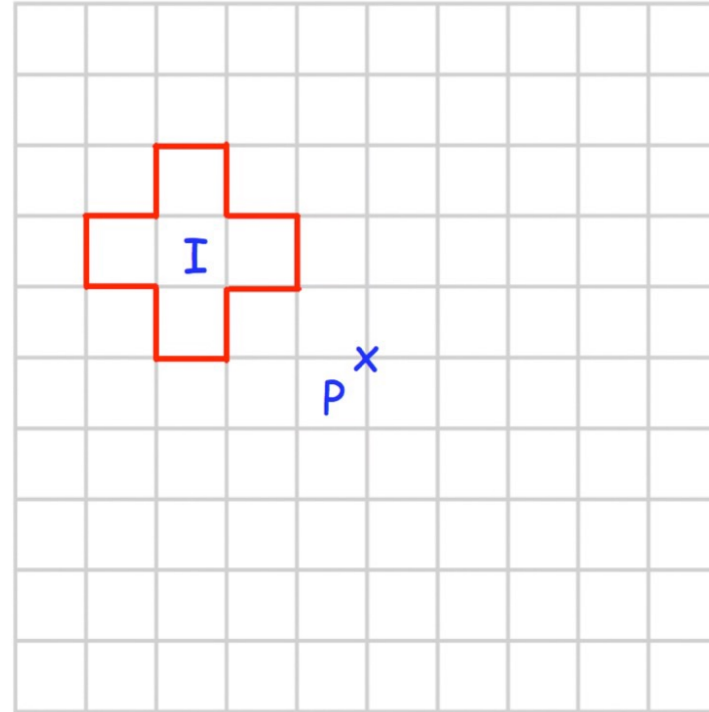

rotate  $270^\circ$  anticlockwise about P

Describe fully the single transformation that takes shape A to shape B.

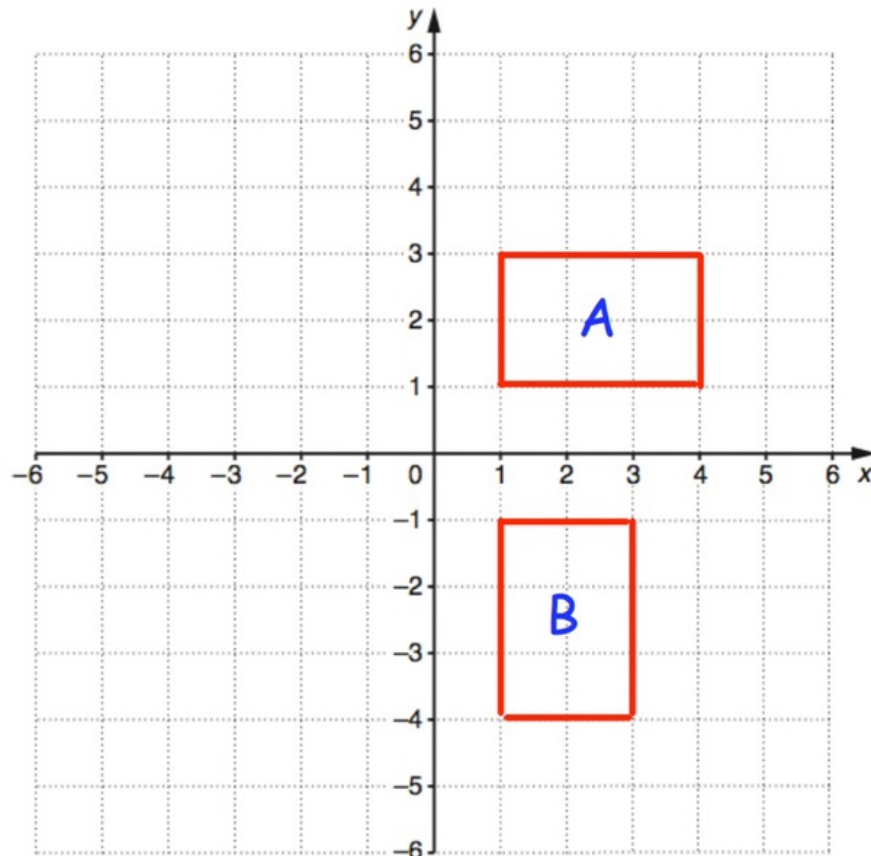

**YOU NEED TO FIND  
CENTRE OF ROTATION**

Describe fully the single transformation that takes shape A to shape B.

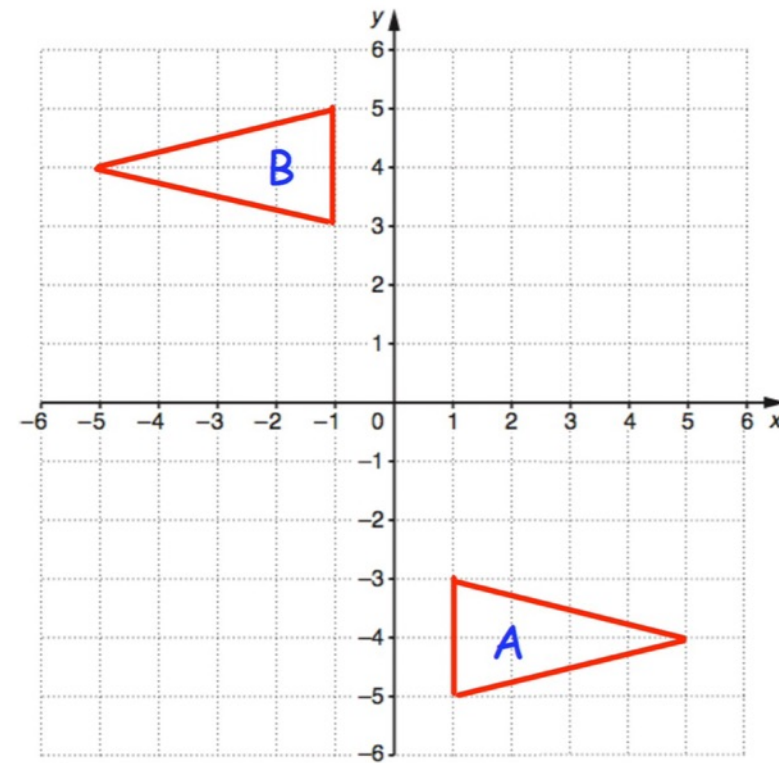
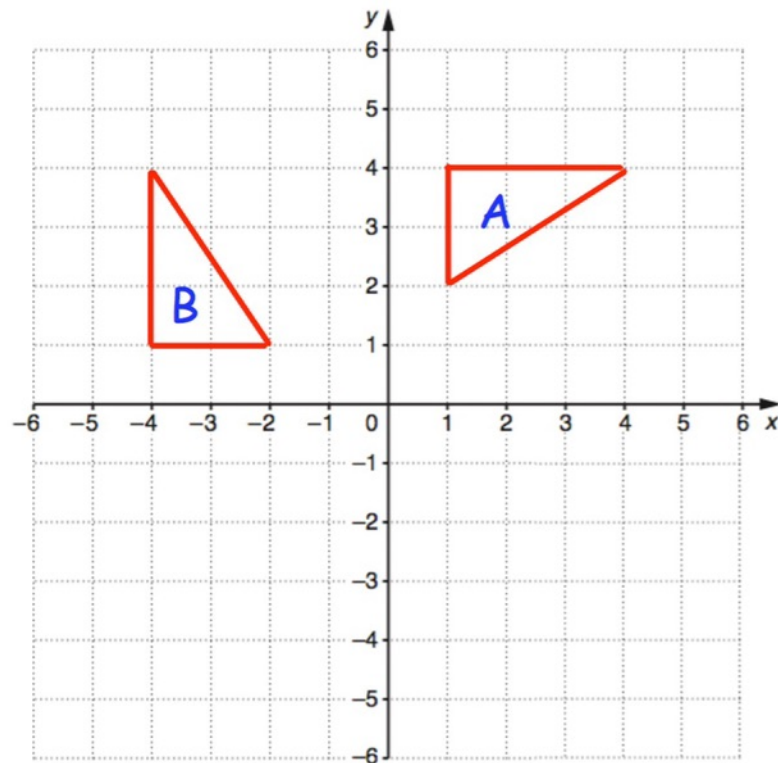

# Enlargement

**Enlarging** a shape changes its size.

To enlarge a shape we need

1. Scale factor
2. Centre of enlargement

# How to draw enlargement when scale factor and centre given

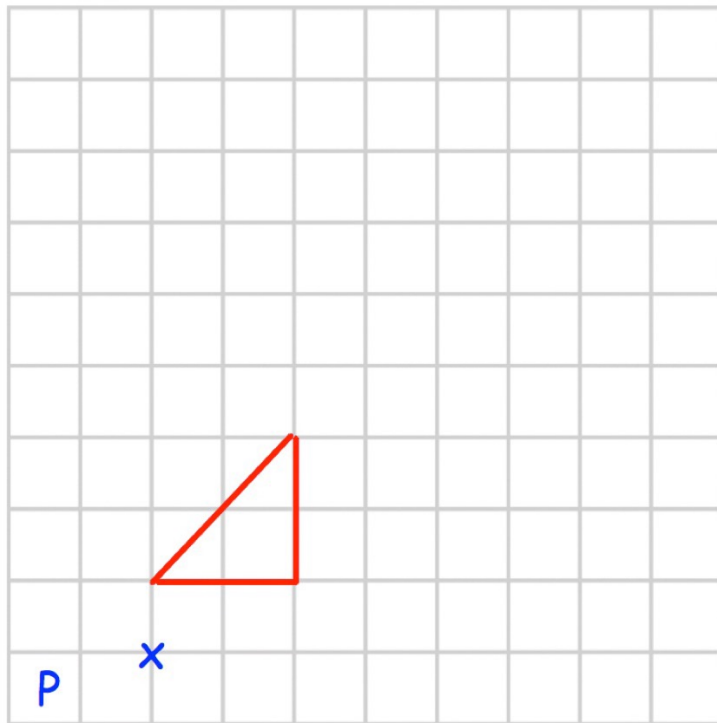

Enlarge by scale factor 3

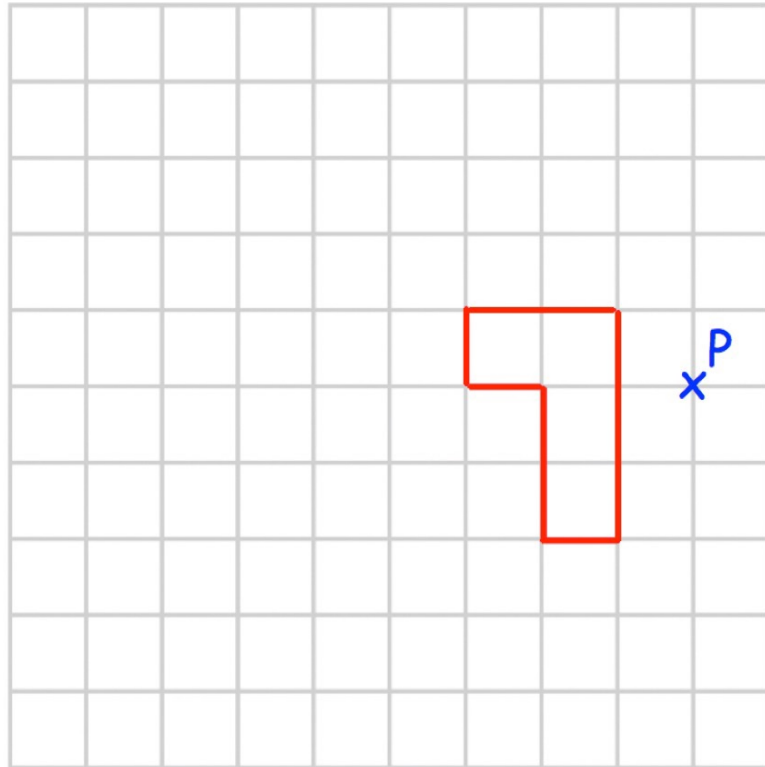

Enlarge by scale factor 2

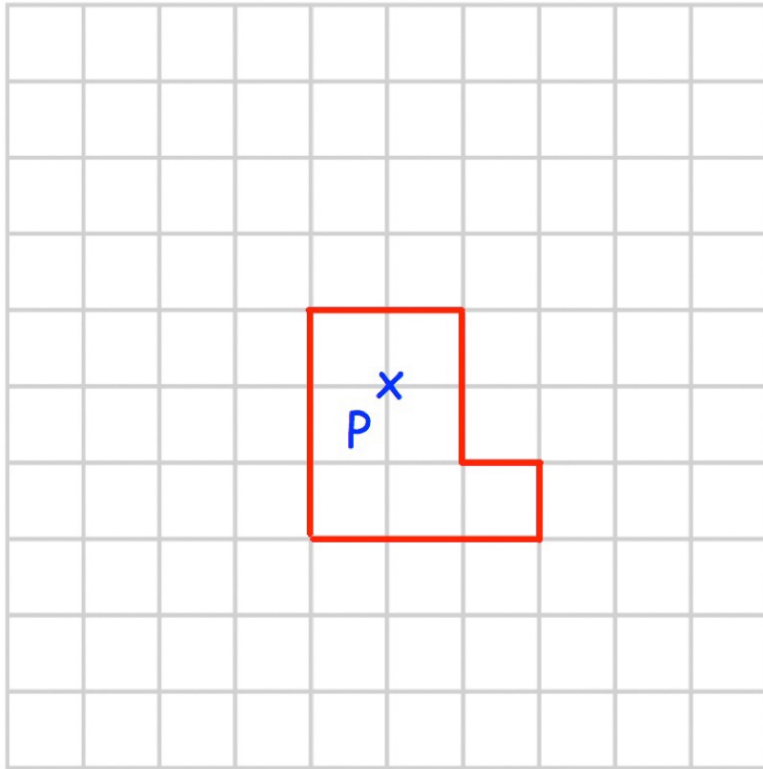

Enlarge by scale factor 2

Describe fully the single transformation that takes shape A to shape B.

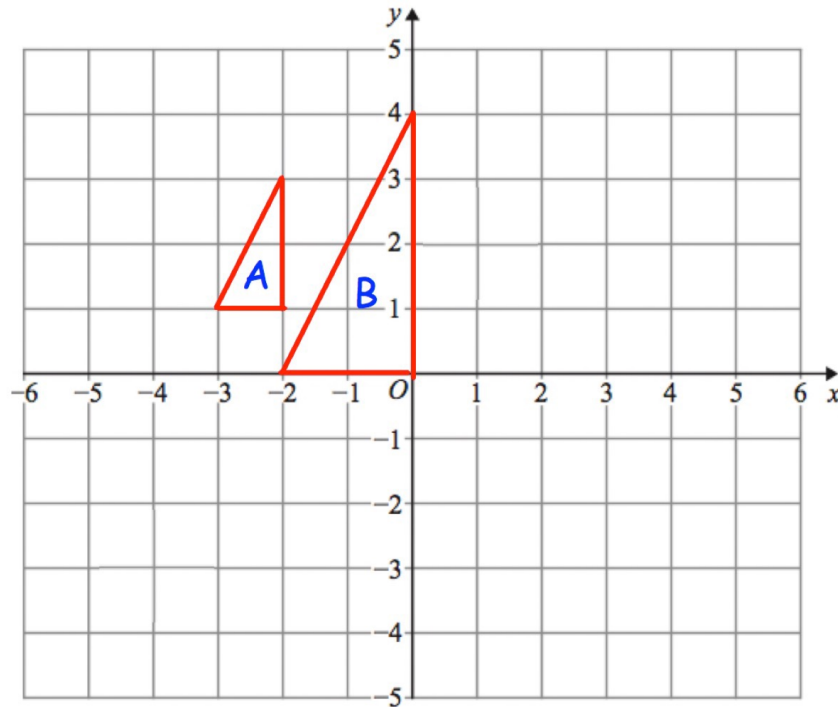

You need to find  
**CENTRE** of enlargement

## Enlargement with **NEGATIVE** scale factor



When you enlarge any shape with negative scale factor , shape with flip into opposite side of centre of enlargement

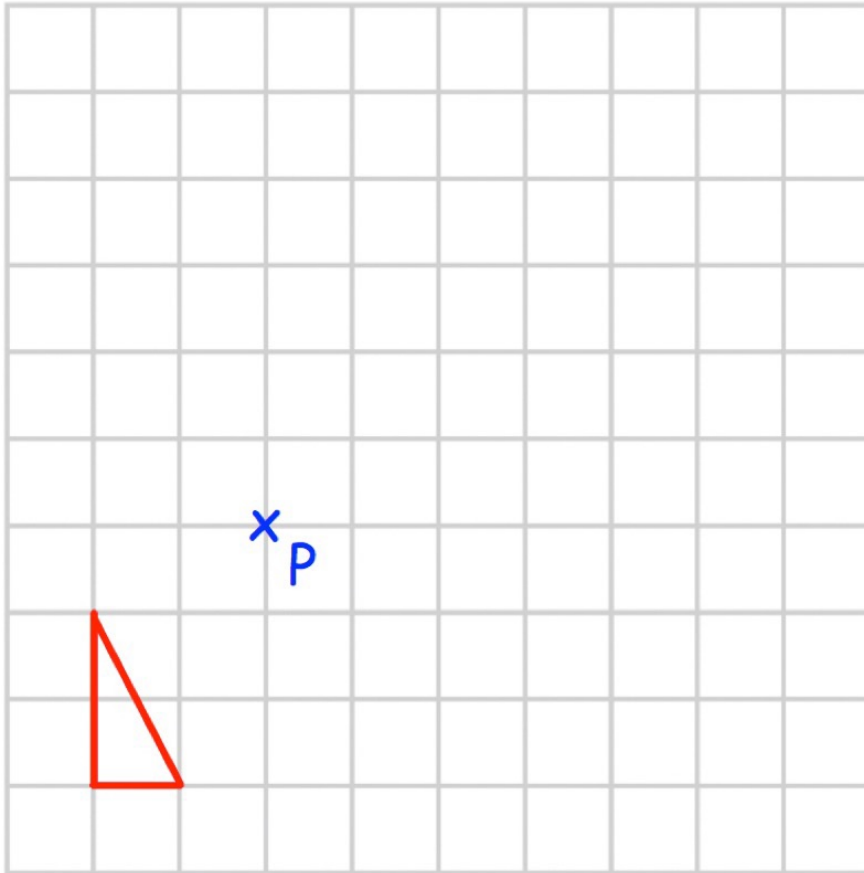

Enlarge by scale factor -2

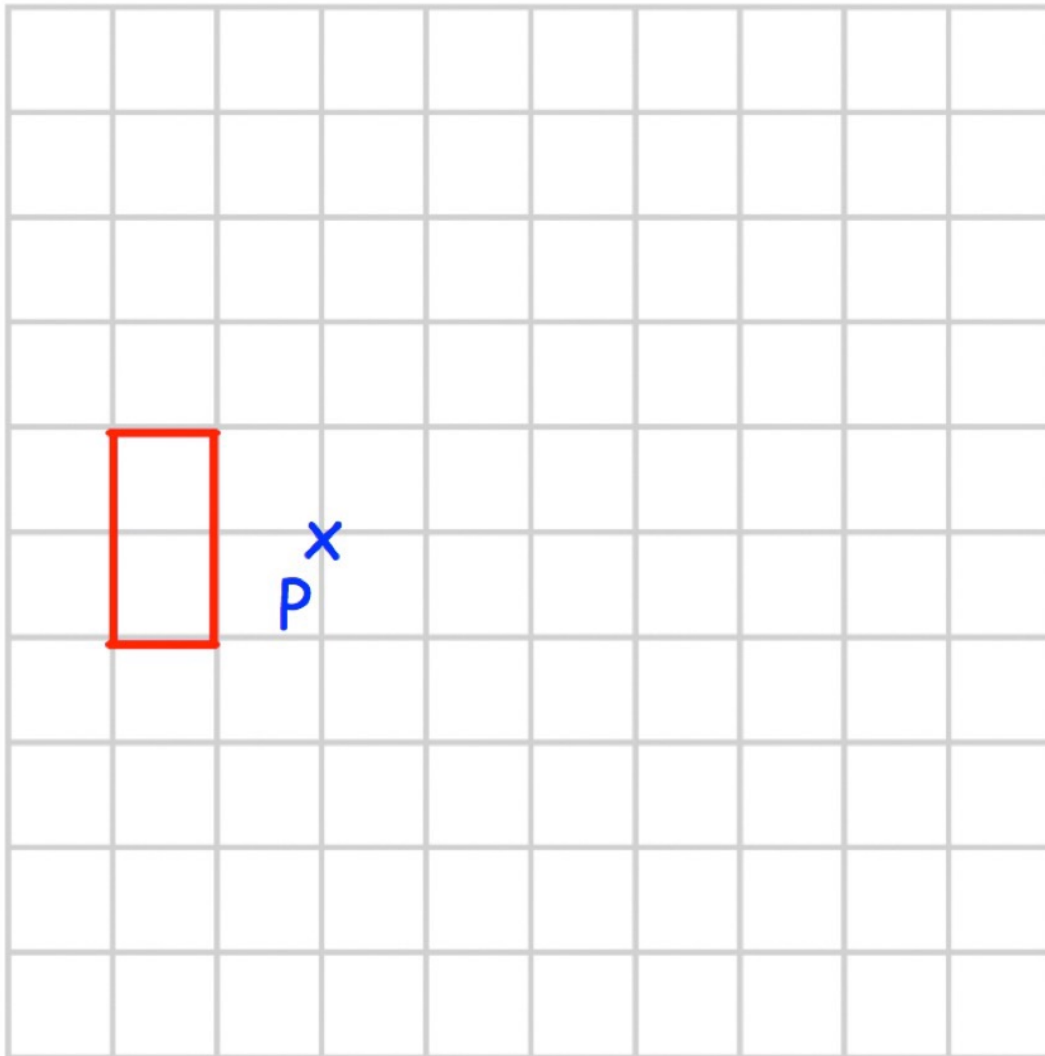

Enlarge by scale factor -3

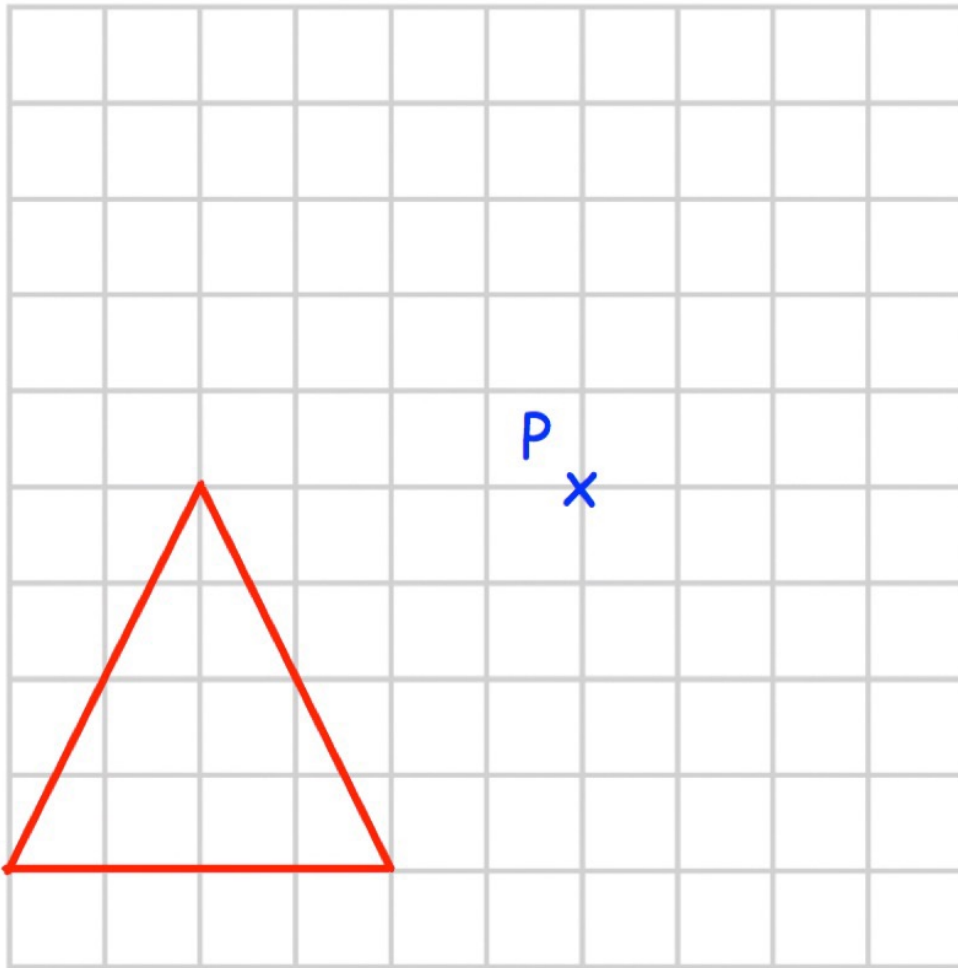

Enlarge by scale factor  $-\frac{1}{2}$

Describe fully the single transformation that takes shape A to shape B.

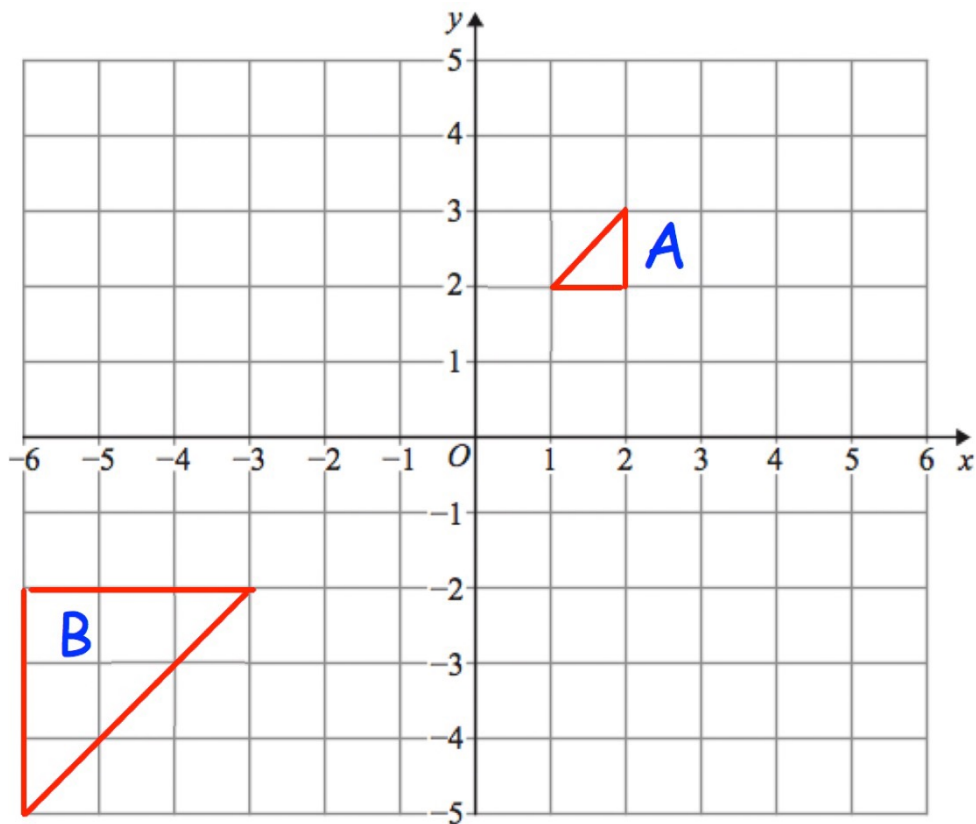

Q1.

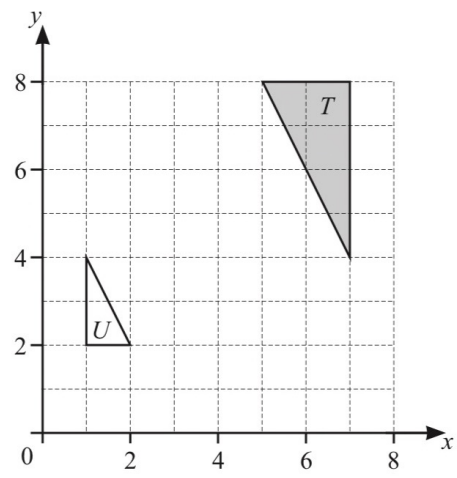

Describe fully the **single** transformation that maps triangle *T* onto triangle *U*.

.....  
.....

[3]

Q2.

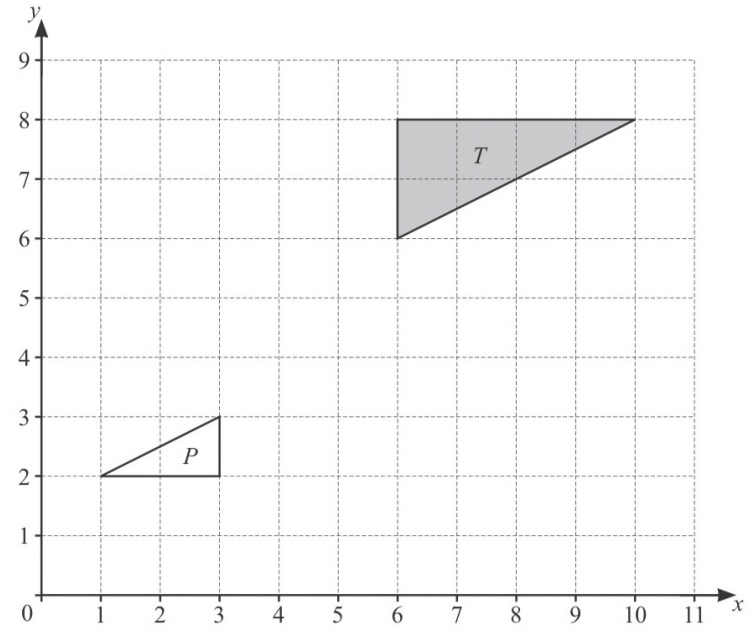

Describe fully the **single** transformation that maps triangle *T* onto triangle *P*.

.....  
.....

[3]

Q3.

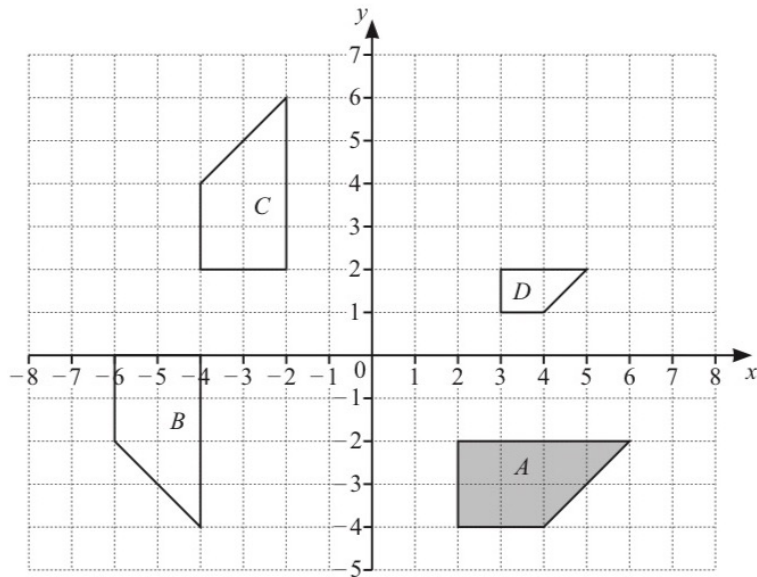

Describe fully the **single** transformation that maps

(a) shape *A* onto shape *B*,

.....  
 ..... [3]

(b) shape *A* onto shape *C*,

.....  
 ..... [2]

(c) shape *A* onto shape *D*.

.....  
 ..... [3]

Q4.

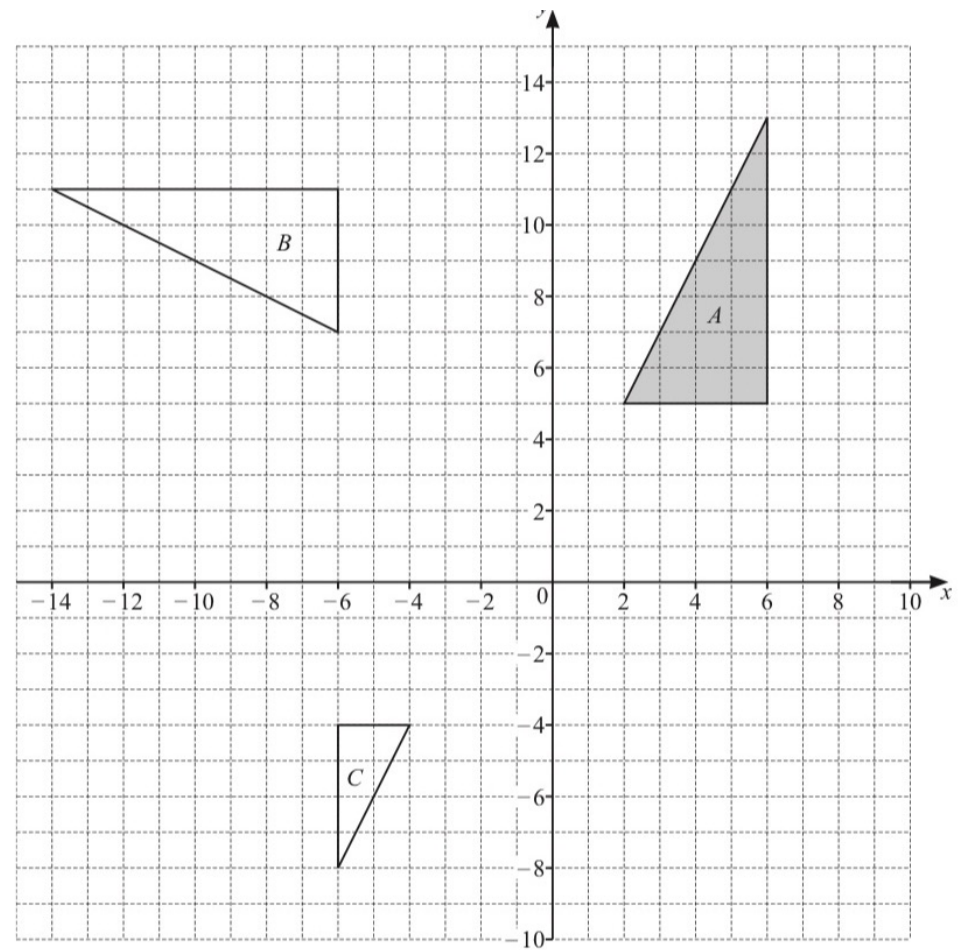

(a) Describe fully the **single** transformation that maps

(i) triangle *A* onto triangle *B*,

.....  
 ..... [3]

(ii) triangle *A* onto triangle *C*.

.....  
 ..... [3]

(b) Draw the image of triangle *A* after a translation by the vector  $\begin{pmatrix} -5 \\ -10 \end{pmatrix}$ .

[2]

(c) Draw the image of triangle *A* after a reflection in the line  $y = 4$ .

[2]

Q5.

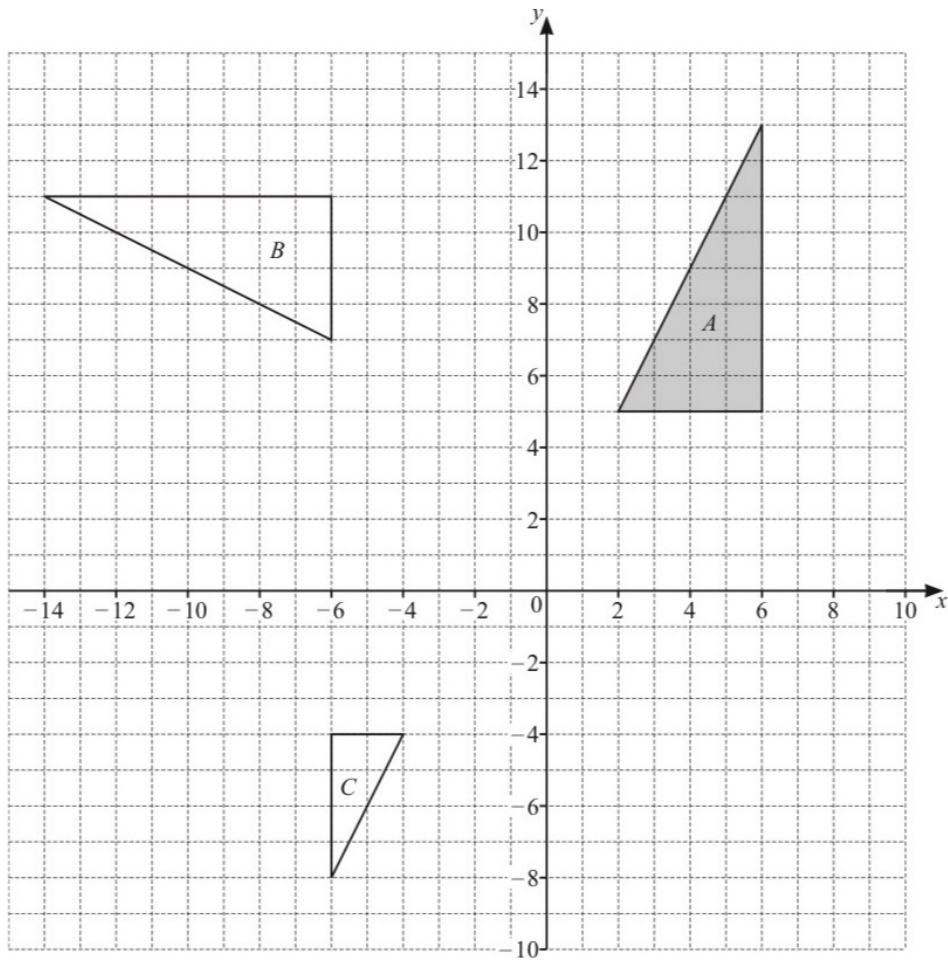

(a) Describe fully the **single** transformation that maps

(i) triangle *A* onto triangle *B*,

.....  
 ..... [3]

(ii) triangle *A* onto triangle *C*.

.....  
 ..... [3]

(b) Draw the image of triangle *A* after a translation by the vector  $\begin{pmatrix} -5 \\ -10 \end{pmatrix}$ . [2]

(c) Draw the image of triangle *A* after a reflection in the line  $y = 4$ . [2]

Q6.

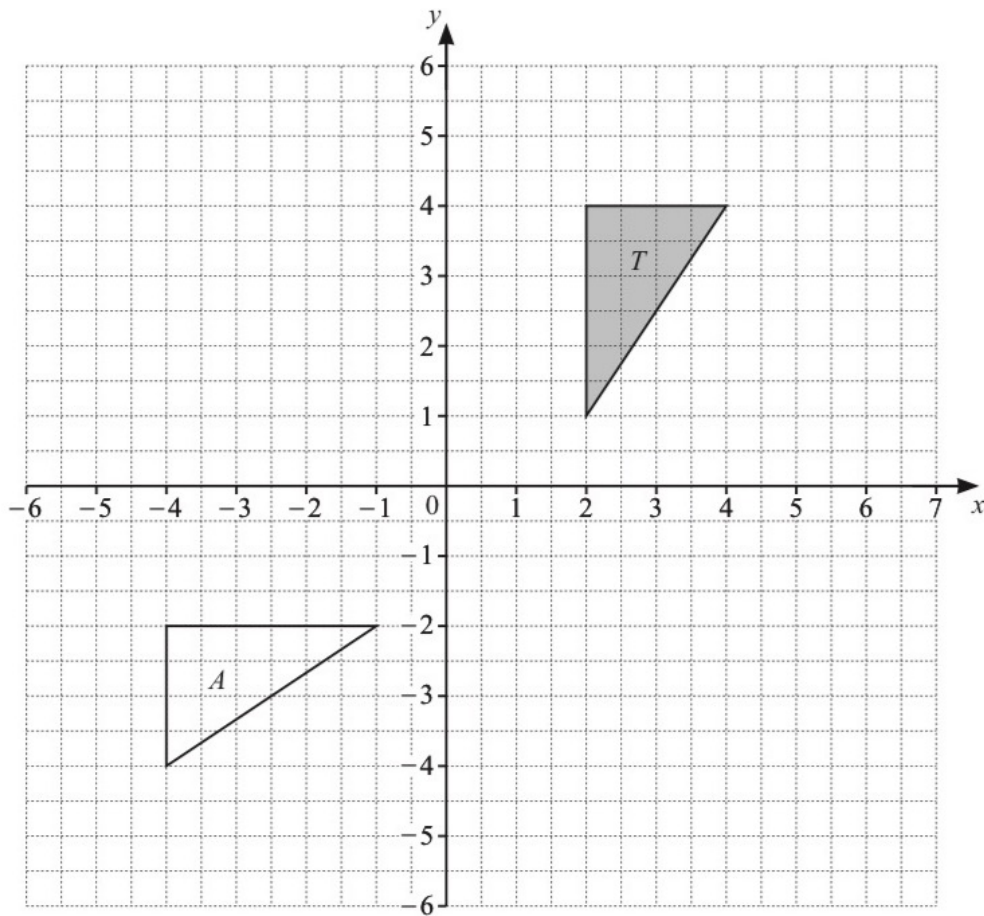

- (a) On the grid, draw the image of
- (i) triangle *T* after a translation by the vector  $\begin{pmatrix} 2 \\ -1 \end{pmatrix}$ , [2]
  - (ii) triangle *T* after a rotation,  $90^\circ$  clockwise, about the origin, [2]
  - (iii) triangle *T* after an enlargement, scale factor  $-\frac{1}{2}$ , centre  $(-2, 3)$ . [2]
- (b) Describe fully the **single** transformation that maps triangle *T* onto triangle *A*.

..... [2]

..... [2]

Q7.

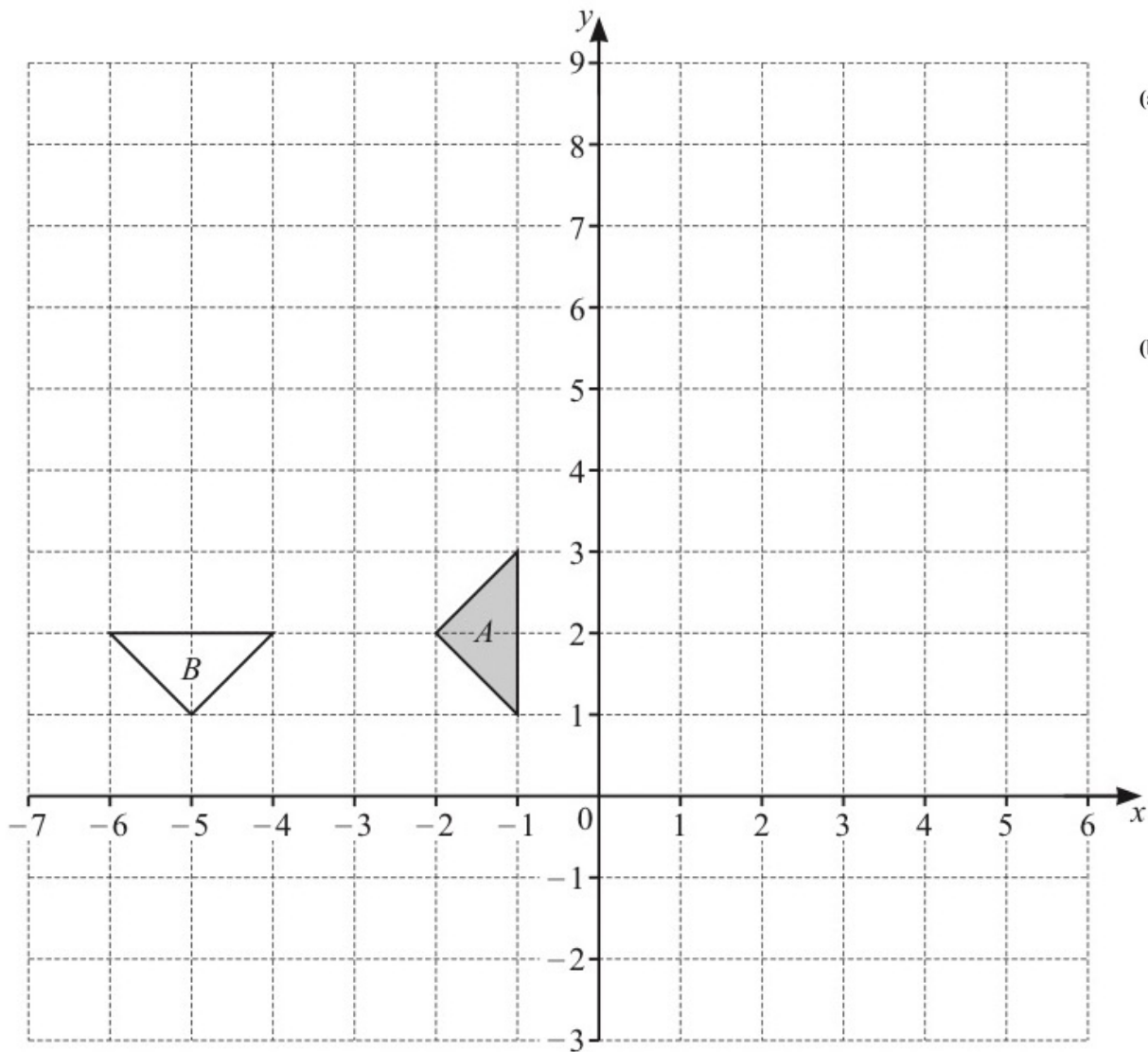

- (a) On the grid, draw the image of triangle *A* after
- (i) a translation by the vector  $\begin{pmatrix} -4 \\ 5 \end{pmatrix}$ , [2]
  - (ii) a reflection in the line  $x = 1$ , [2]
  - (iii) an enlargement, scale factor 2 and centre  $(-5, -2)$ . [2]
- (b) Describe fully the **single** transformation that maps triangle *A* onto triangle *B*.
- .....
- ..... [3]

Q8.

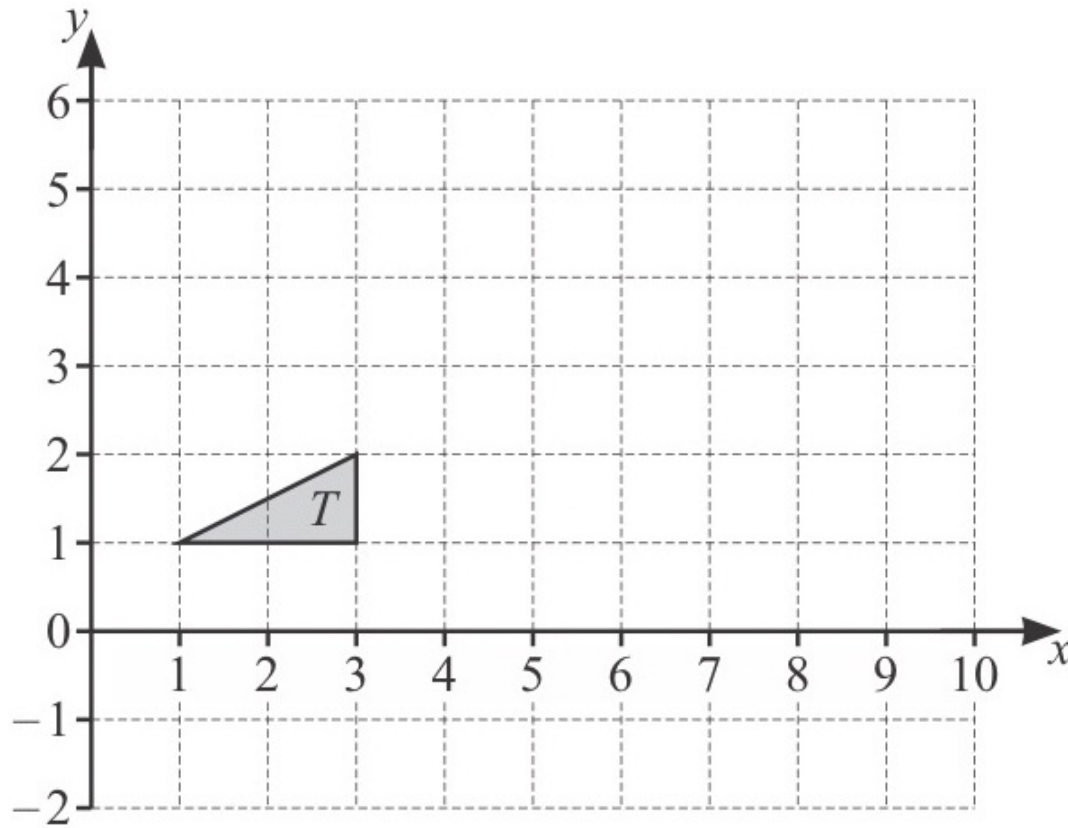

(i) Enlarge triangle  $T$  by scale factor 3, centre  $(0, 2)$ . [2]

(ii) (a) Rotate triangle  $T$  about  $(4, 2)$  by  $90^\circ$  clockwise. Label the image  $P$ . [2]

(b) Reflect triangle  $T$  in the line  $x + y = 6$ . Label the image  $Q$ . [3]

(c) Describe fully the **single** transformation that maps triangle  $P$  onto triangle  $Q$ .

.....  
..... [2]

Q9.

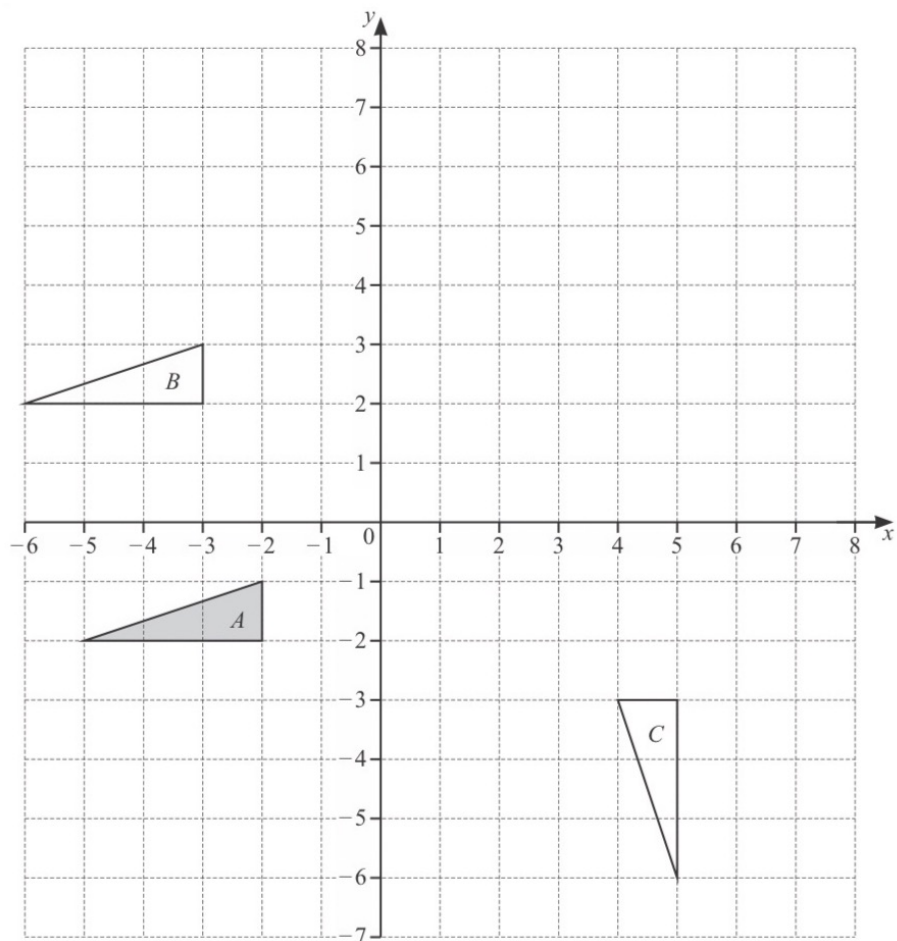

(i) Describe fully the **single** transformation that maps

(a) triangle *A* onto triangle *B*,

.....  
..... [2]

(b) triangle *A* onto triangle *C*.

.....  
..... [3]

(ii) (a) Draw the image of triangle *A* after reflection in  $y = 2$ . [2]

(b) Draw the image of triangle *A* after enlargement by scale factor  $-2$ , centre  $(-1, 1)$ . [2]

Q10.

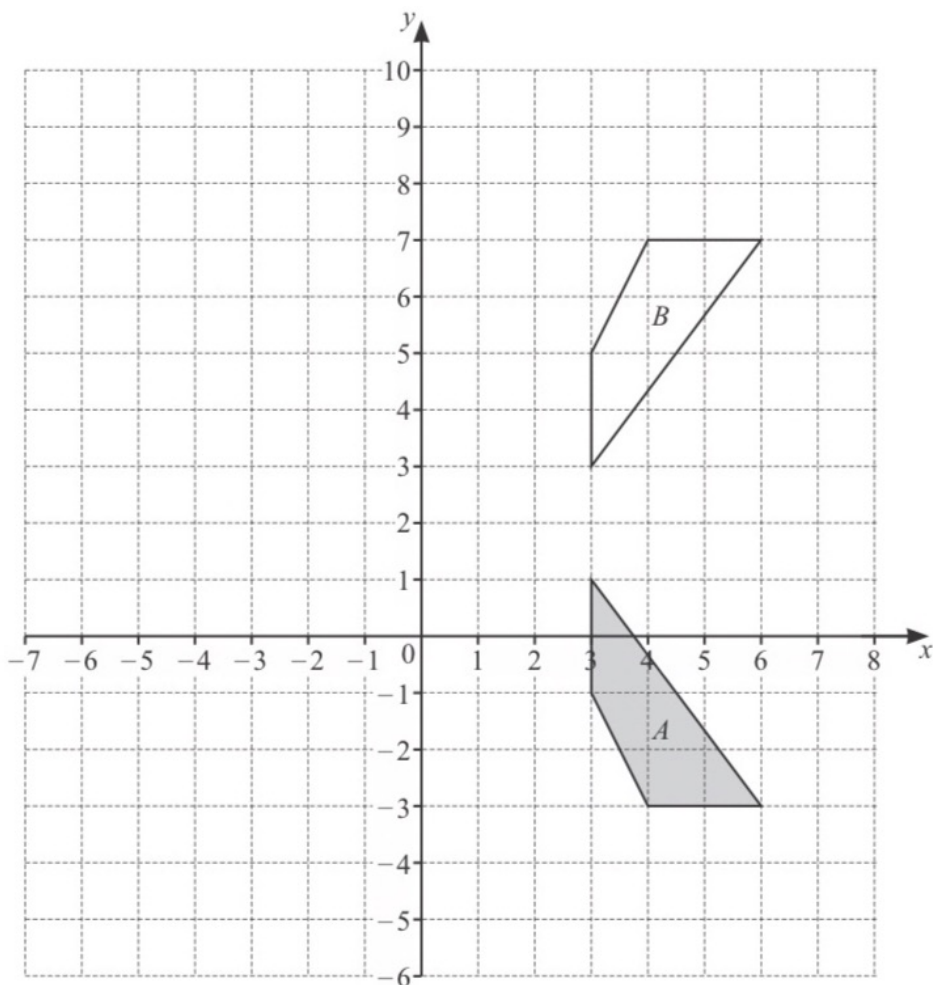

(a) Describe fully the **single** transformation that maps shape *A* onto shape *B*.

.....

..... [2]

(b) Rotate shape *A*  $90^\circ$  clockwise about the point  $(-1, 2)$ . [2]

(c) Enlarge shape *A* by scale factor  $-2$ , centre  $(2, 0)$ . [2]