

Oct / Nov 2023
Maths IGCSE
ต้องได้ A* หรือ 9
เท่านั้น



คอร์สตะลุยโจทย์

Intensive Maths IGCSE
booster Oct Nov 2023

ด่วนรับเพียง 15 คนเท่านั้น !!

- ✓ เนื้อหาอัดแน่นจากทีมครูคุณภาพที่คร่ำครึ
- ✓ เน้นเทคนิคการทำข้อสอบรวมถึงการตอบคำถาม
- ✓ เข้มข้นด้วยการวิเคราะห์ข้อสอบ
- ✓ แนวข้อสอบที่หลากหลายและสมบูรณ์ที่สุด
- ✓ **FREE!** วิดีโอสำหรับทบทวนย้อนหลัง

Cambridge International

Date & Time
Saturday to Sunday
9-10, 16-17 Sep 2023
9:00-12:00 am. / 1:00-4:00 pm.

Edexcel

Date & Time
Saturday to Sunday
23-24, 30 Sep, 1 Oct 2023
9:00-12:00 am. / 1:00-4:00 pm.

HOT
PRICE!

19,260-



REGISTER NOW

IGCSE Board EDEXCEL

Part *KruSie*

Content

- ✓ Angles and circle theorems. Page 2
- ✓ Circles and sector. Page 58
- ✓ Mensuration (perimeter, area, volume) Page 76
- ✓ Pythagoras and Trigonometry. Page 113
- ✓ Compound measurement and Travel time graphs. Page 159
- ✓ Symmetry. Page 175
- ✓ Construction. Page 183
- ✓ Transformation. Page 193



Angles and Circle theorem



By Kru ชี

1. Acute angle

2. Obtuse angle

3. Right angle

4. Straight angle

5. Reflex angle

6. Angle at point or angle around point

Vertically opposite angles are equal

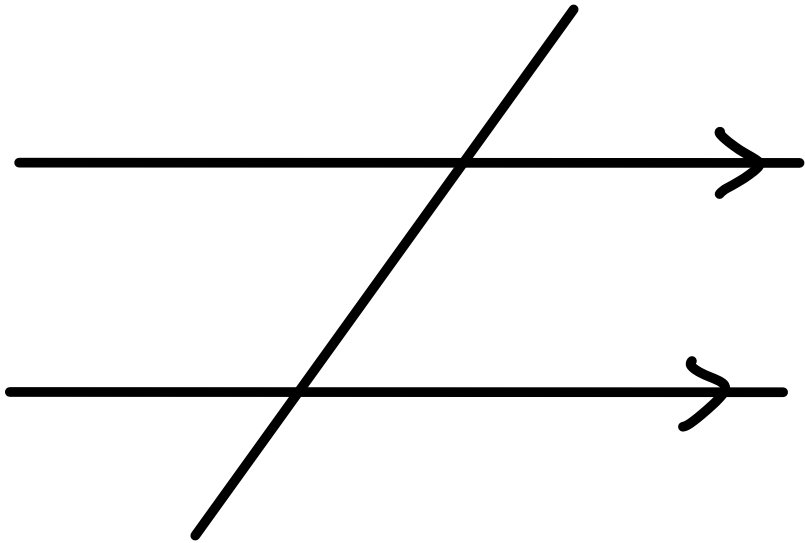

1. Corresponding angles are equal

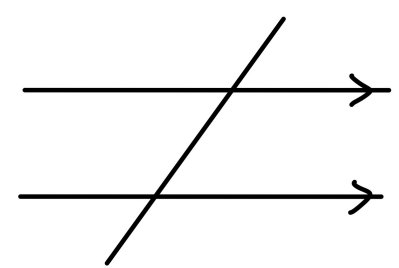
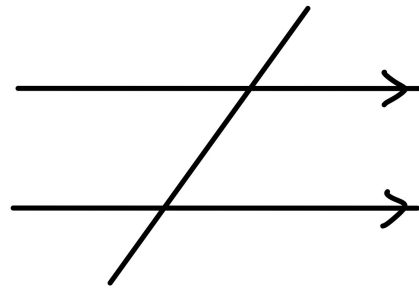
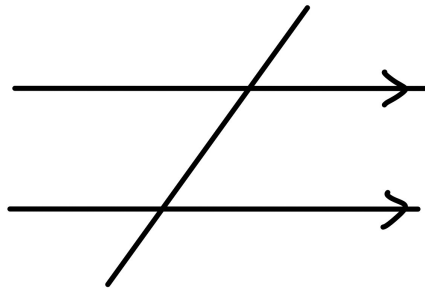
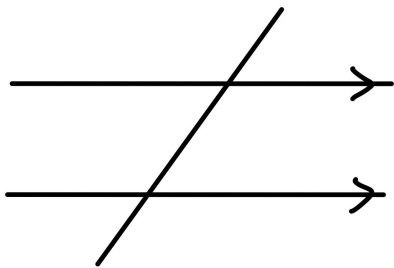

2. Alternate angles are equal

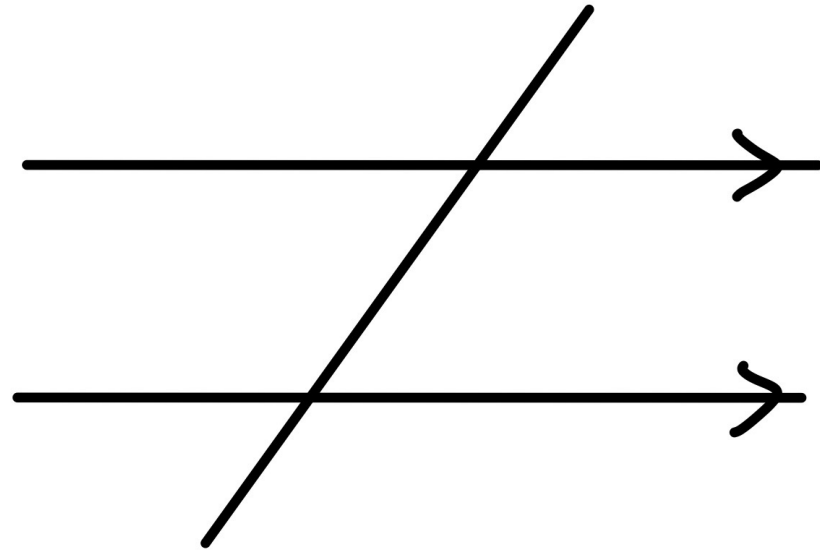
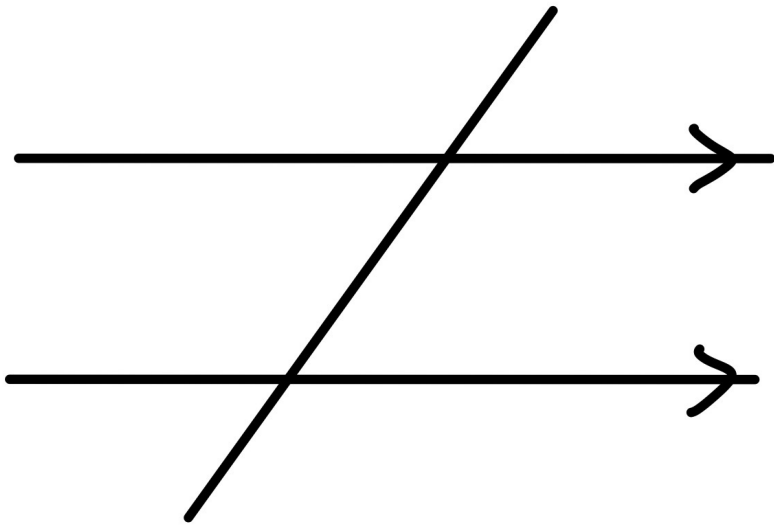

3. Co-interior angles add up to 180 degree (allied angles)

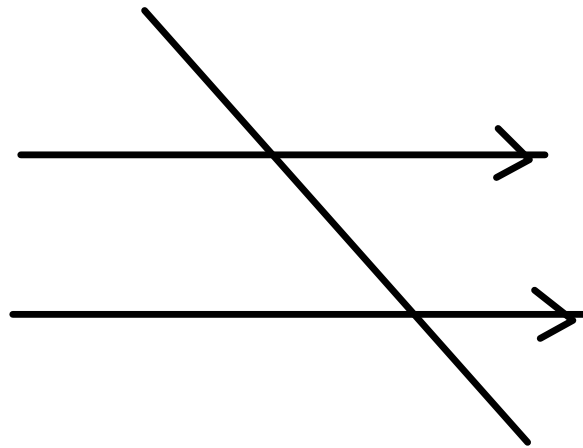
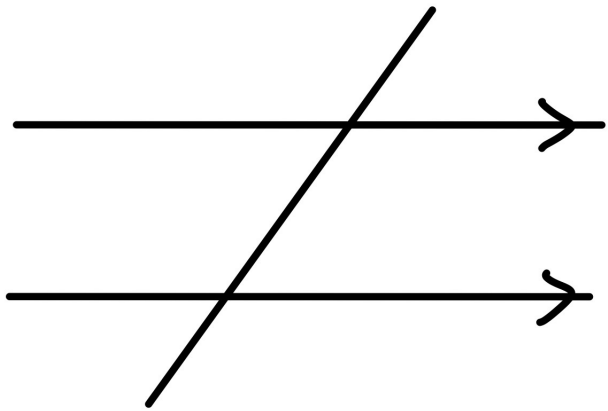

Bearing

Find the bearing of A from B

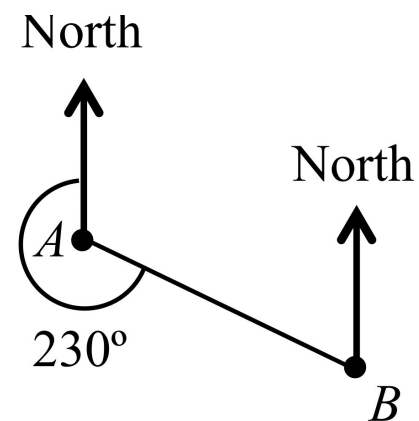
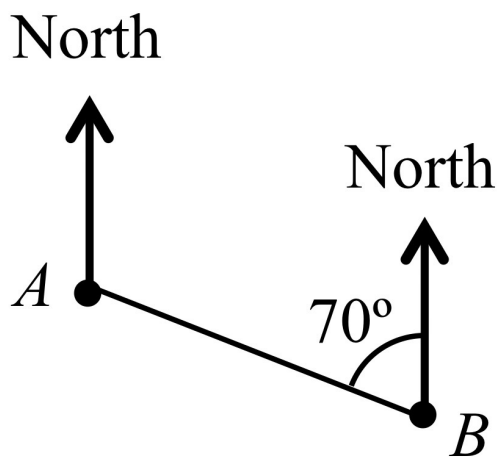

Names of polygons

3 sides = Triangle

4 sides = Quadrilateral

5 sides = Pentagon

6 sides = Hexagon

7 sides = Heptagon

8 sides = Octagon

9 sides = Nonagon

10 sides = Decagon

11 sides = Undecagon

12 sides = Dodecagon



When n is number of sides in Polygon

$$\text{Sum of interior angles} = 180 \times (n-2)$$

For regular polygon , you can find each interior angle

Because each angle is equal



$$\text{One interior angle} = \frac{180 \times (n-2)}{n}$$



Sum of exterior angles in any polygon
is always **360** degree



For regular polygons

$$\text{One exterior angle} = \frac{360}{n}$$

 For regular polygons

$$\begin{aligned} \text{Number of sides of polygons} \\ = \frac{360}{\text{exterior}} \end{aligned}$$

1. The isosceles triangle , when 2 sides are radius

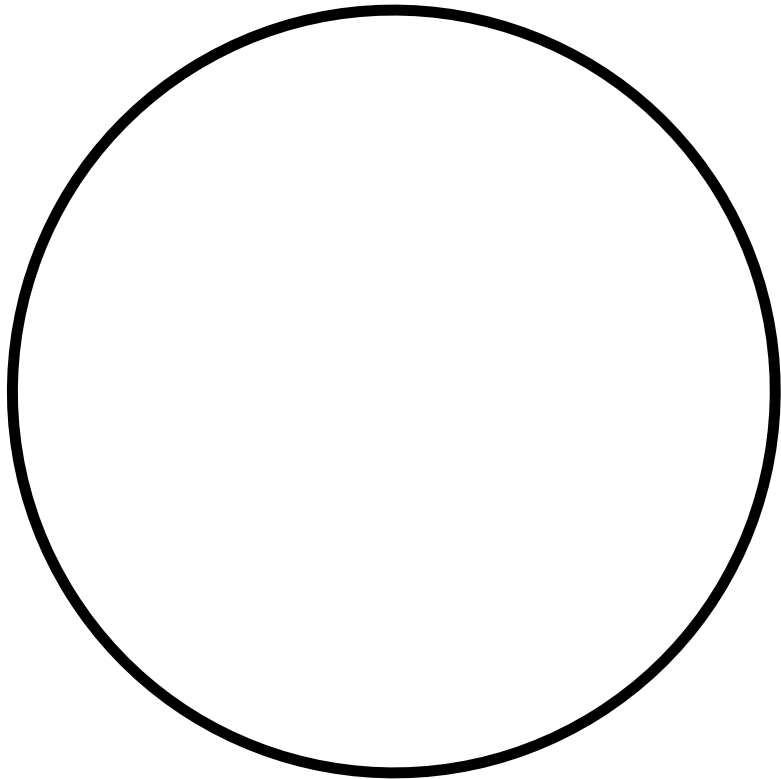

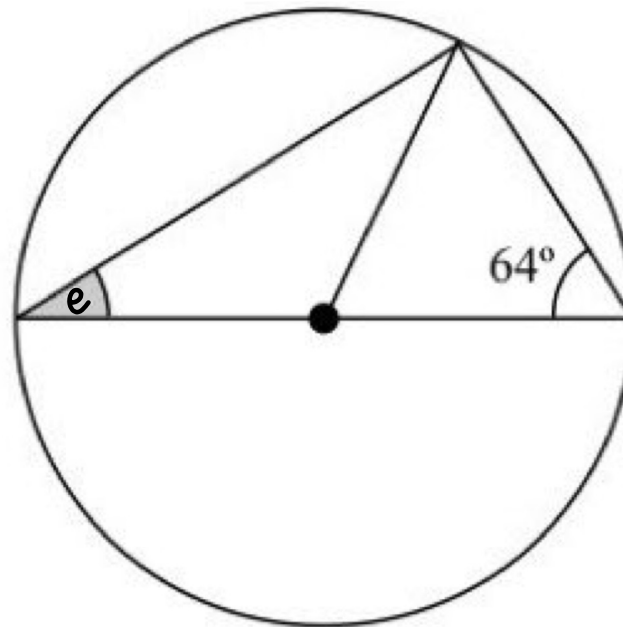
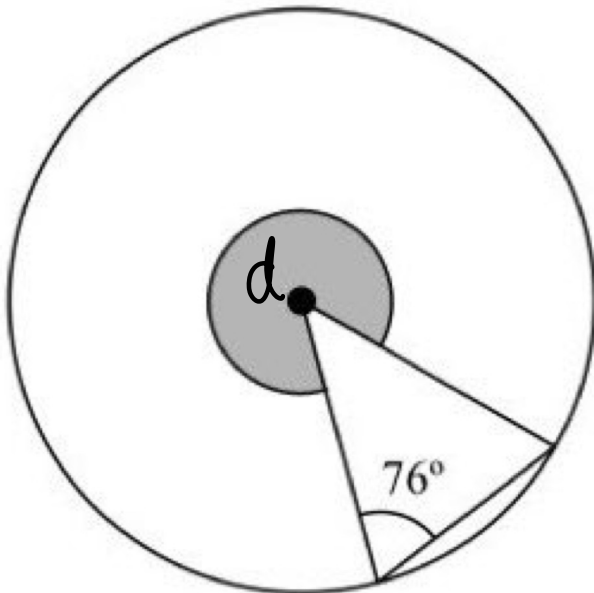
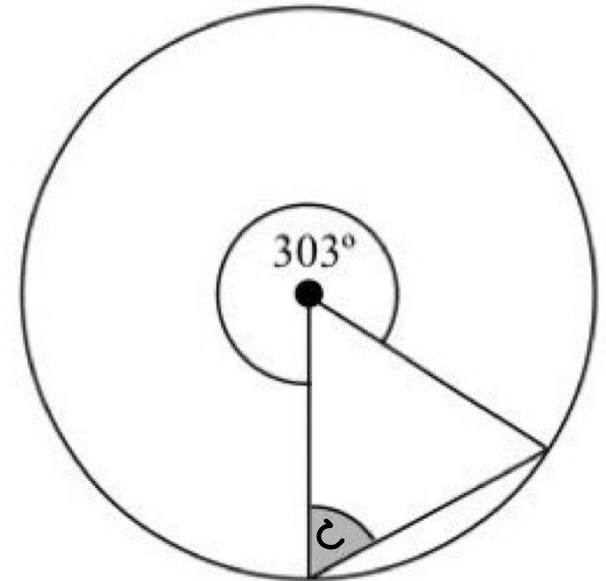
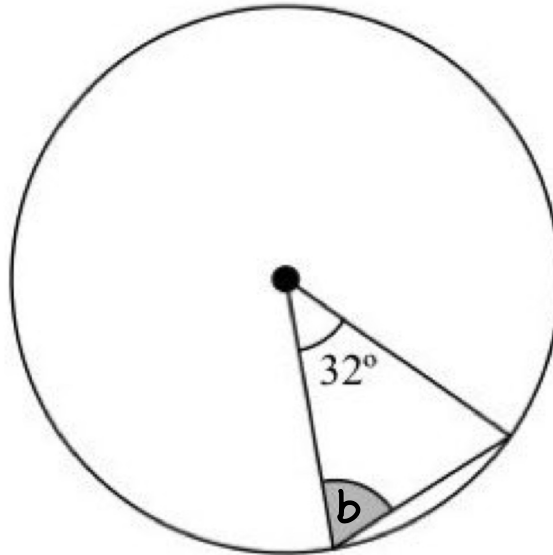
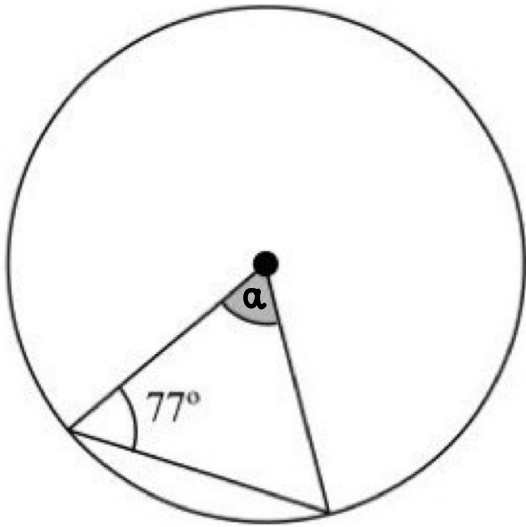

2. Angle in semicircle is 90°

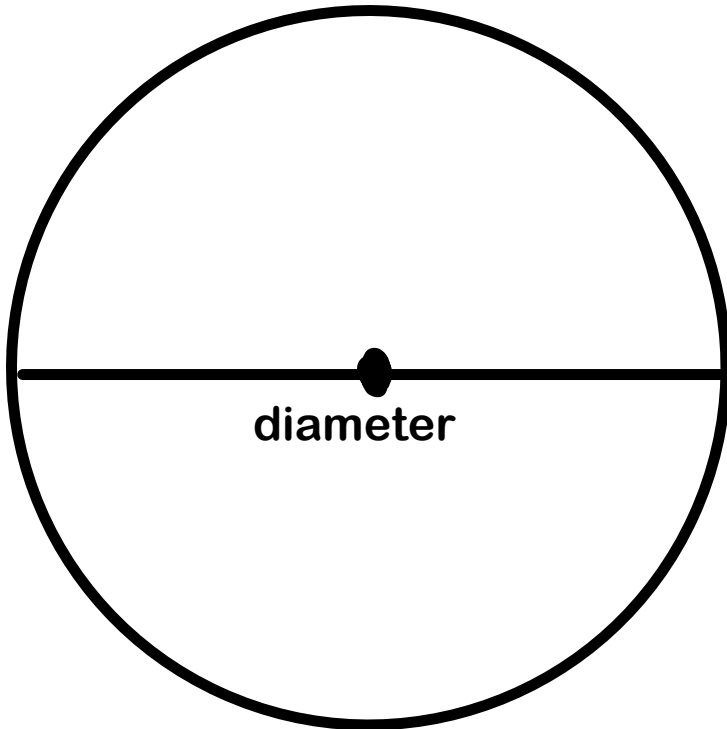

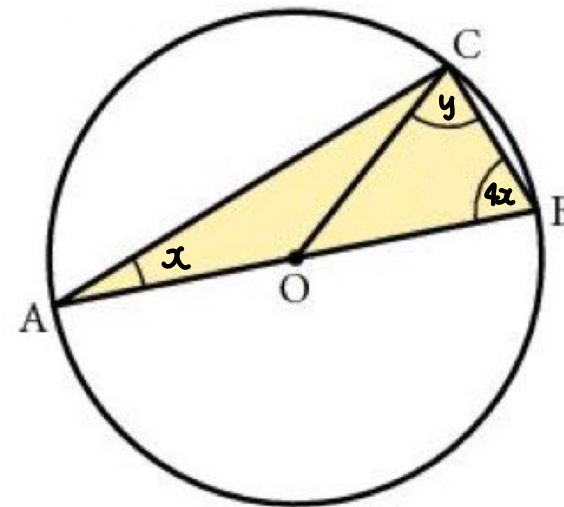
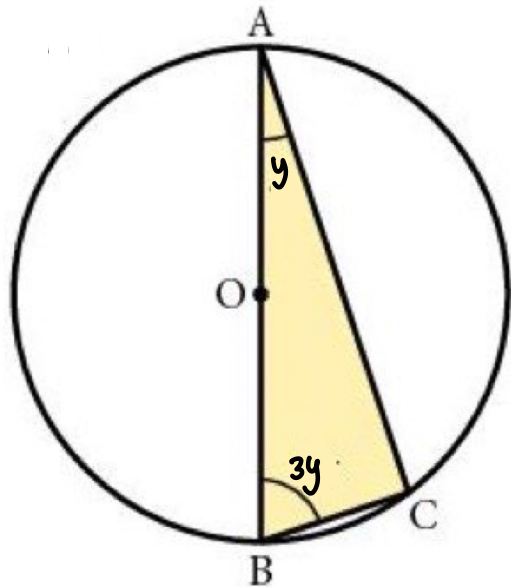
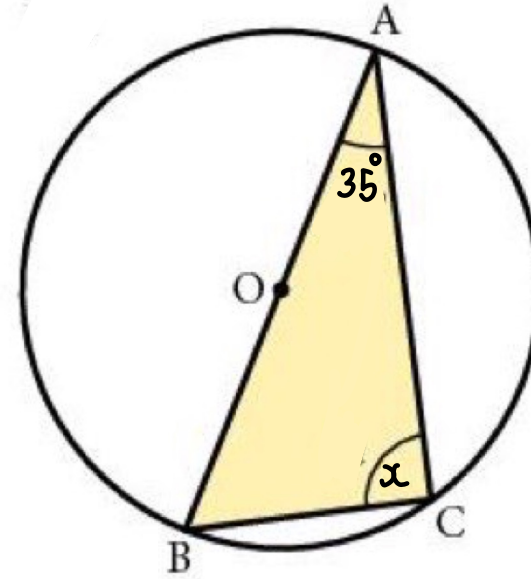
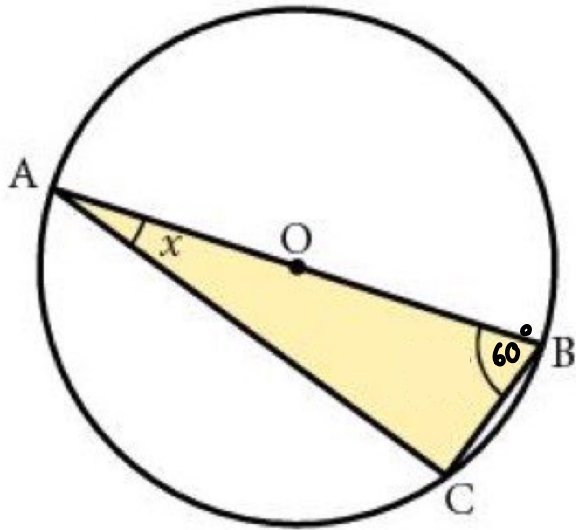

3. Angle at the centre is twice of angle at the circumference

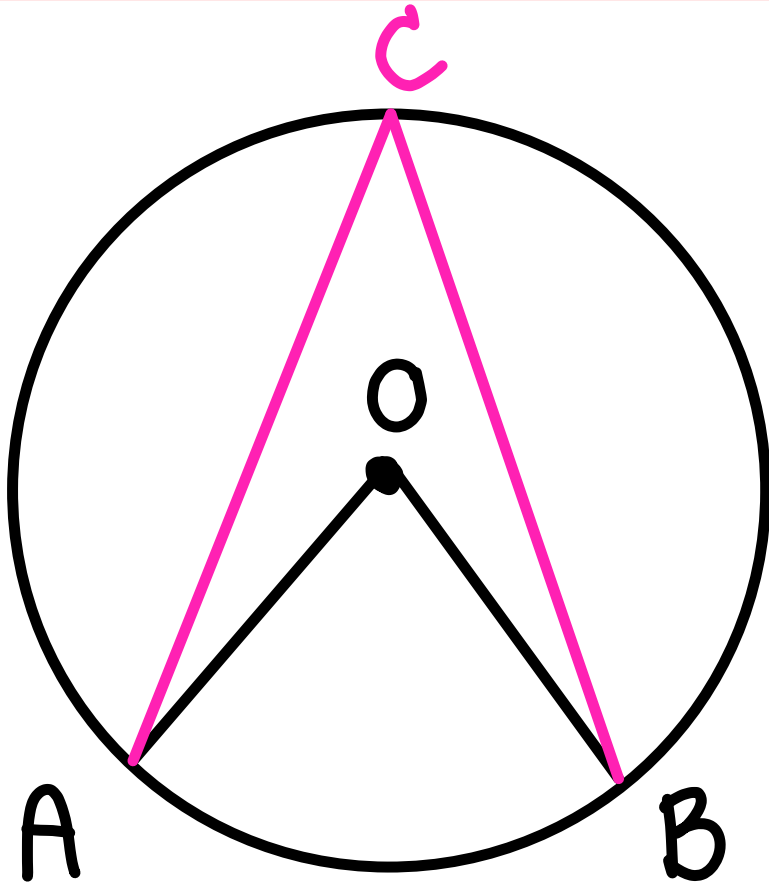

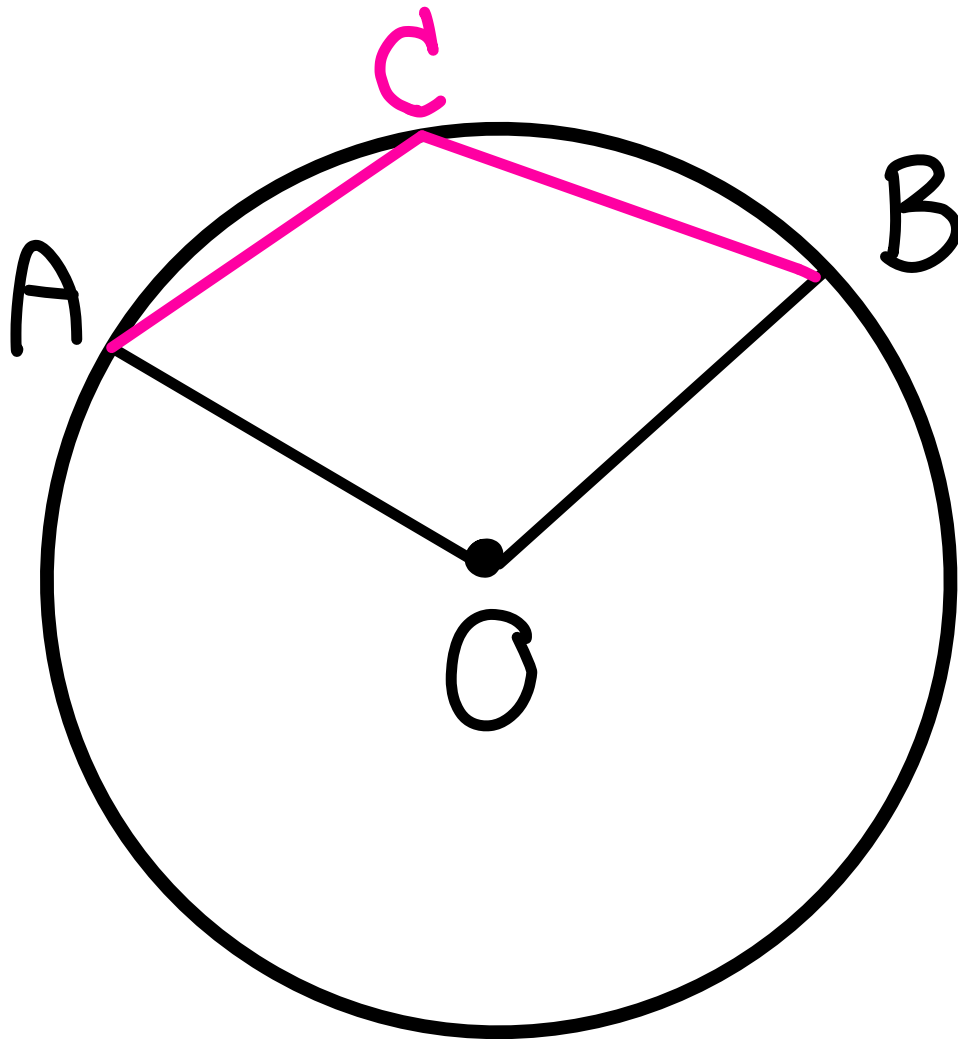

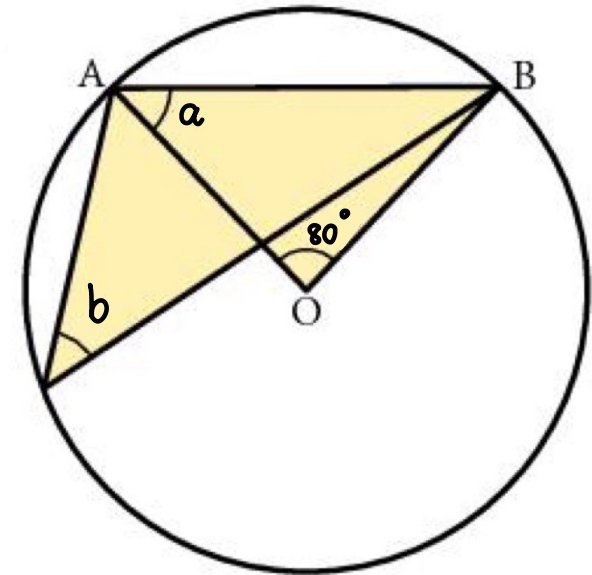
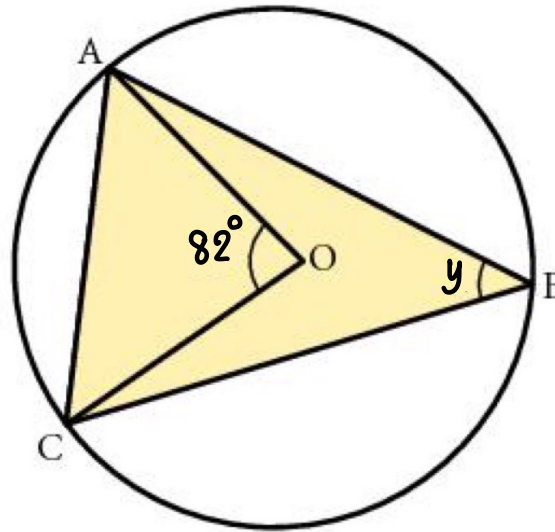
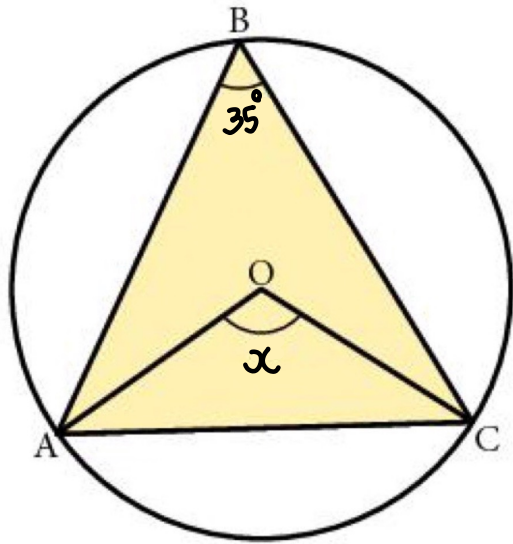

4. Angles in same segment are equal

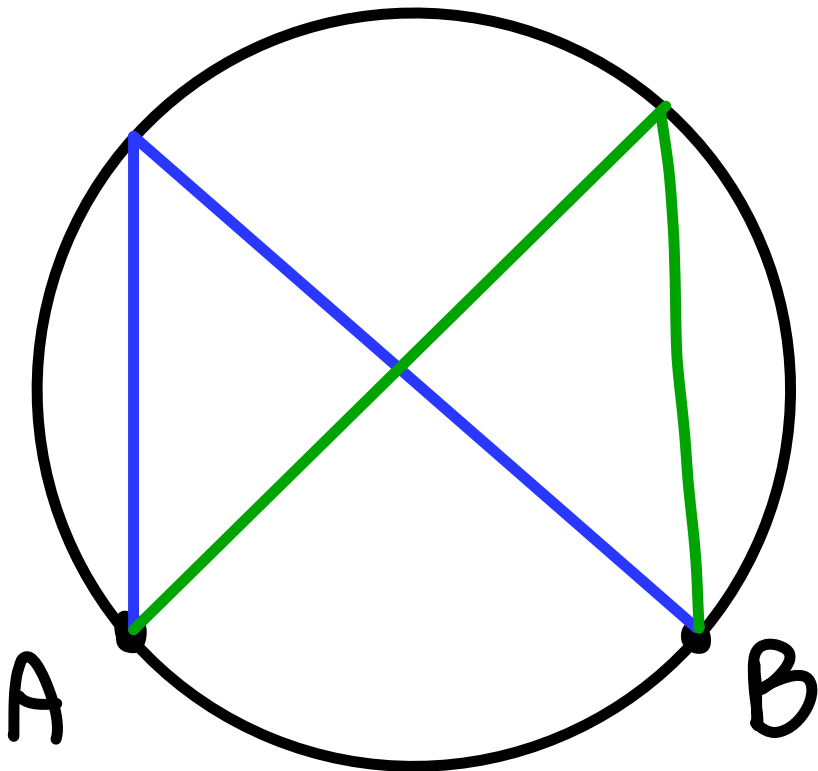

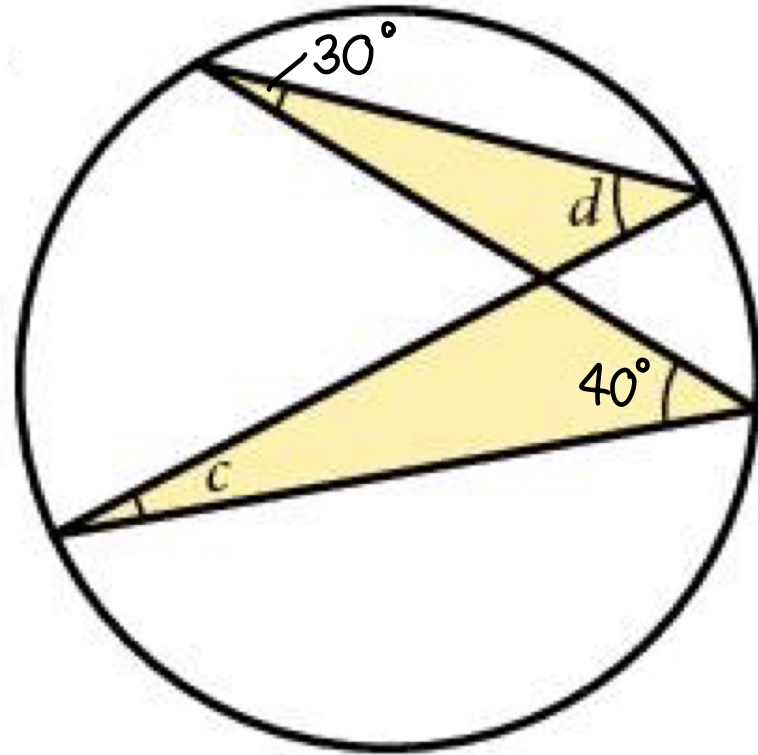
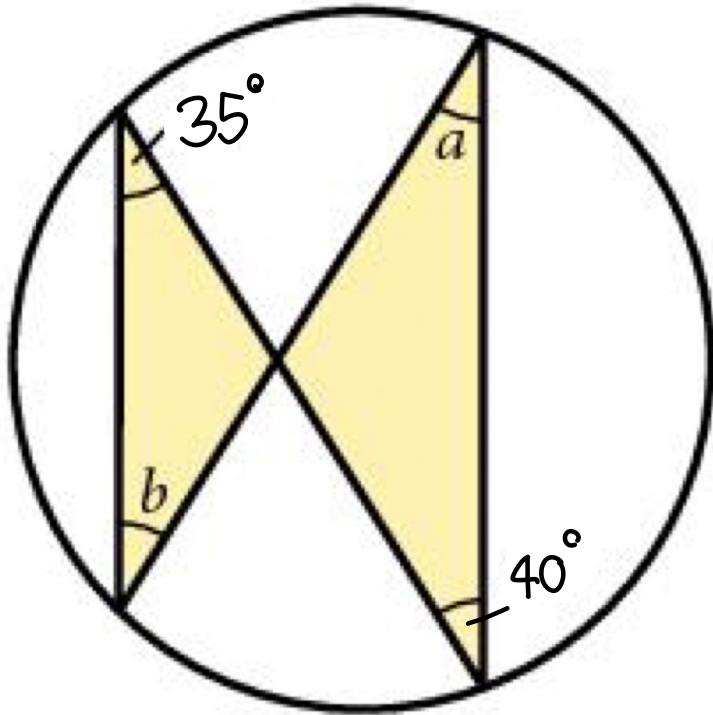

5. Opposite angles in cyclic quadrilateral add up to 180°

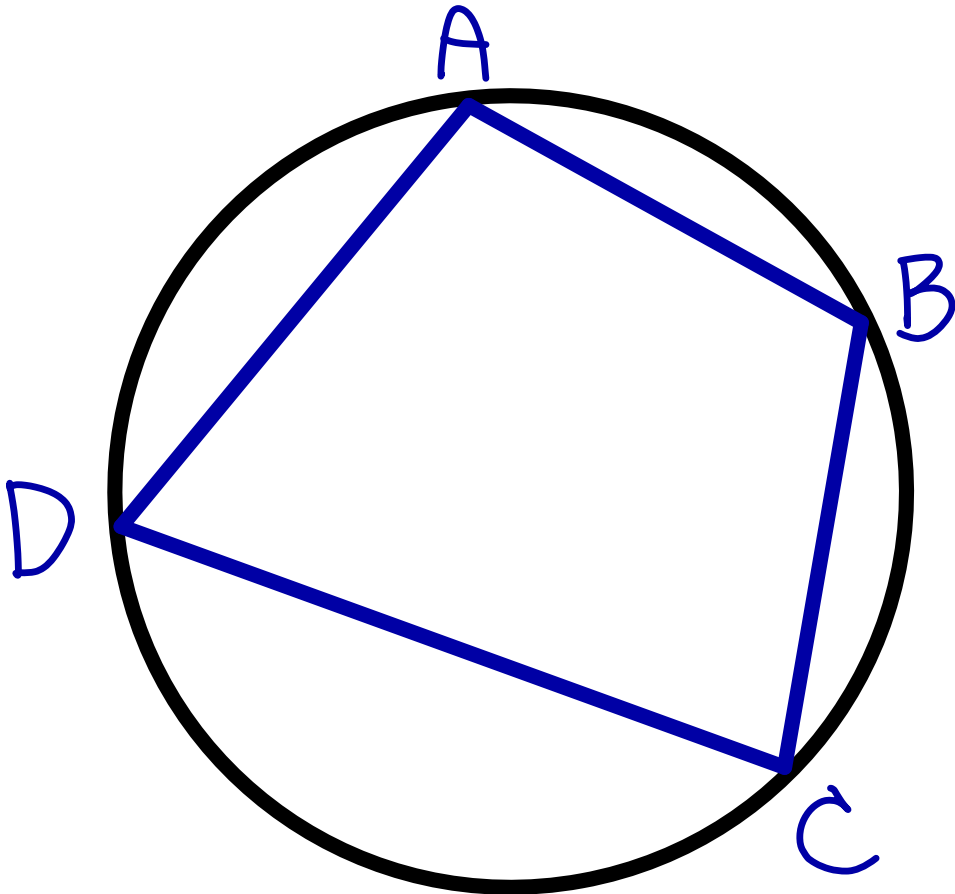

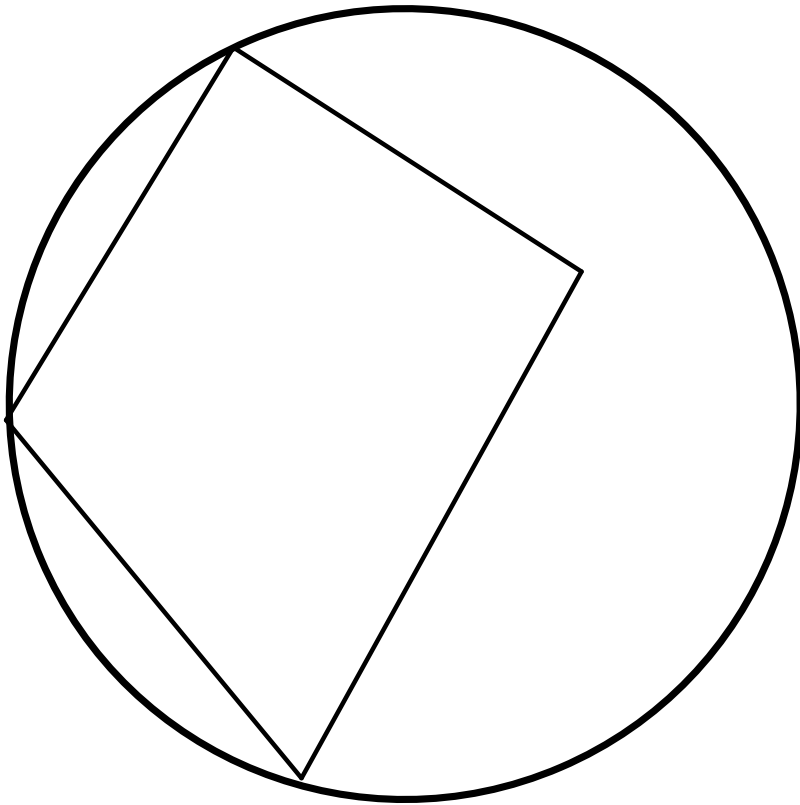

Not cyclic quadrilateral !

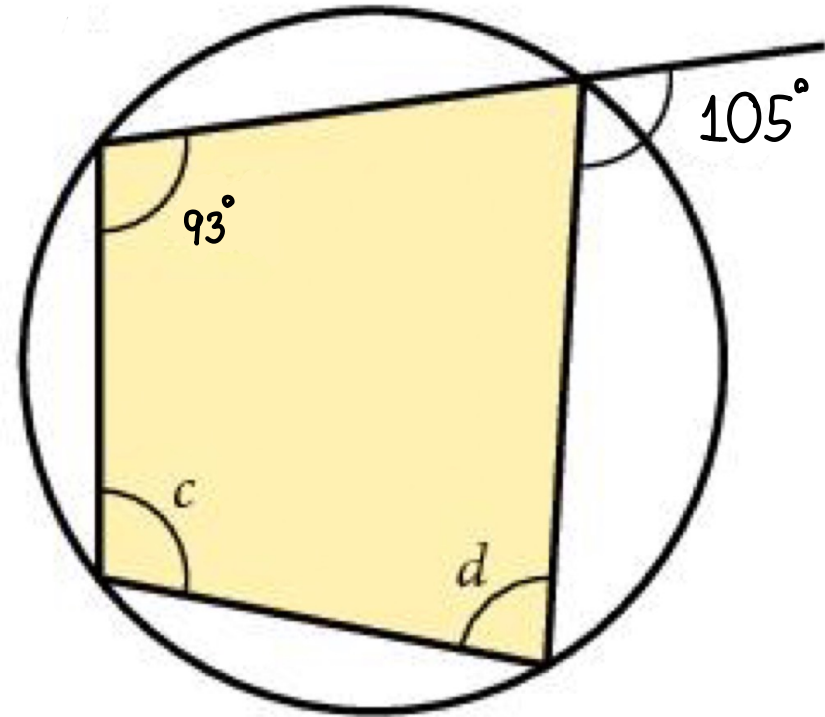
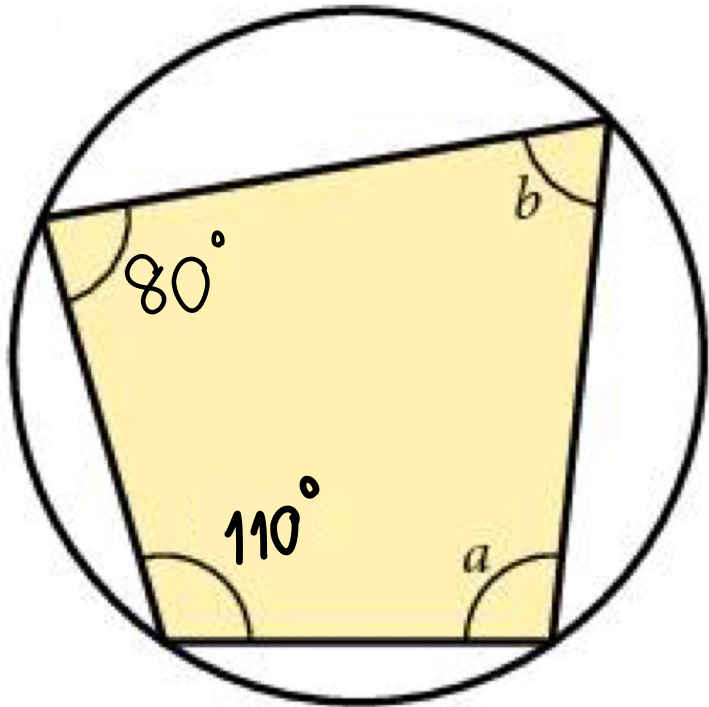

6. Angle between radius and tangent is 90°

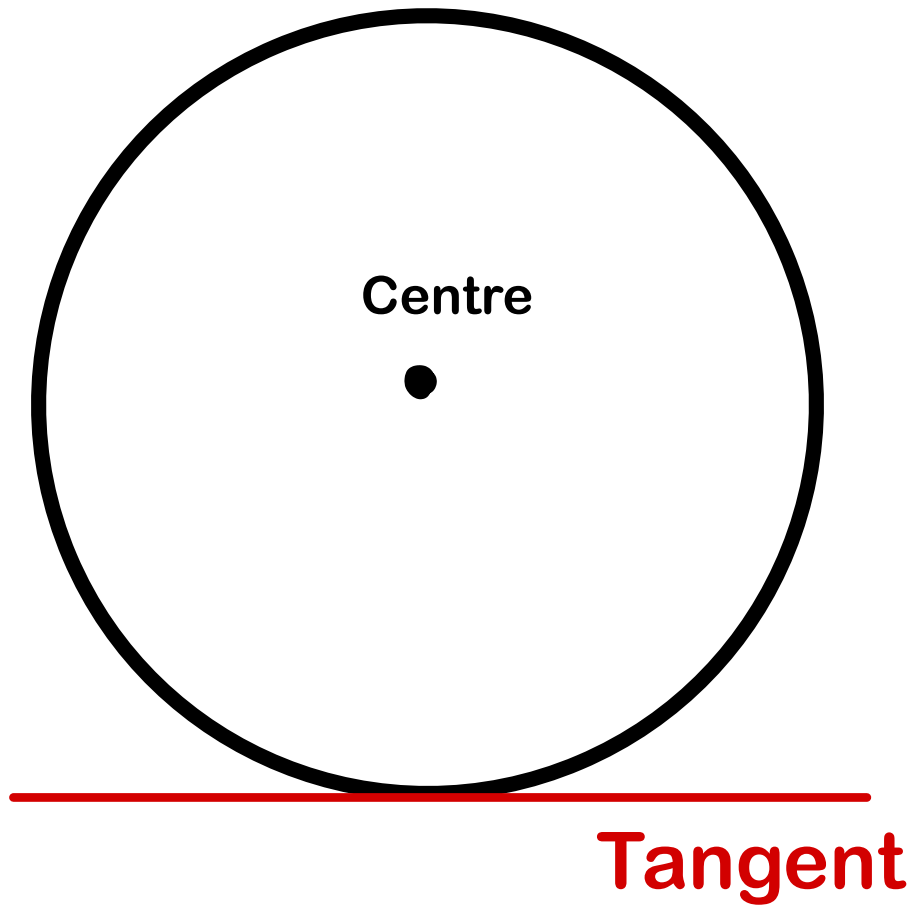

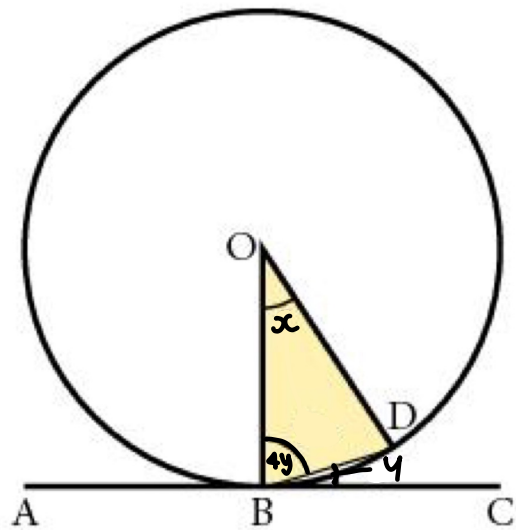
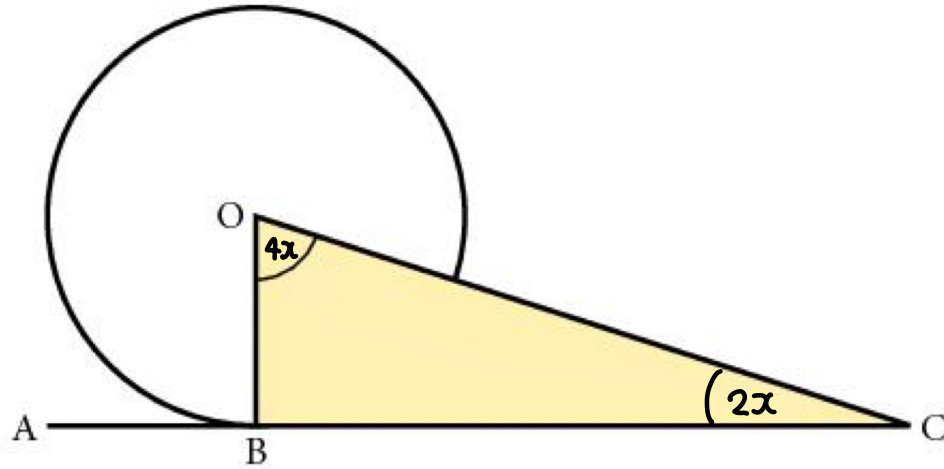

7. The tangents from the point outside circle are equal in length

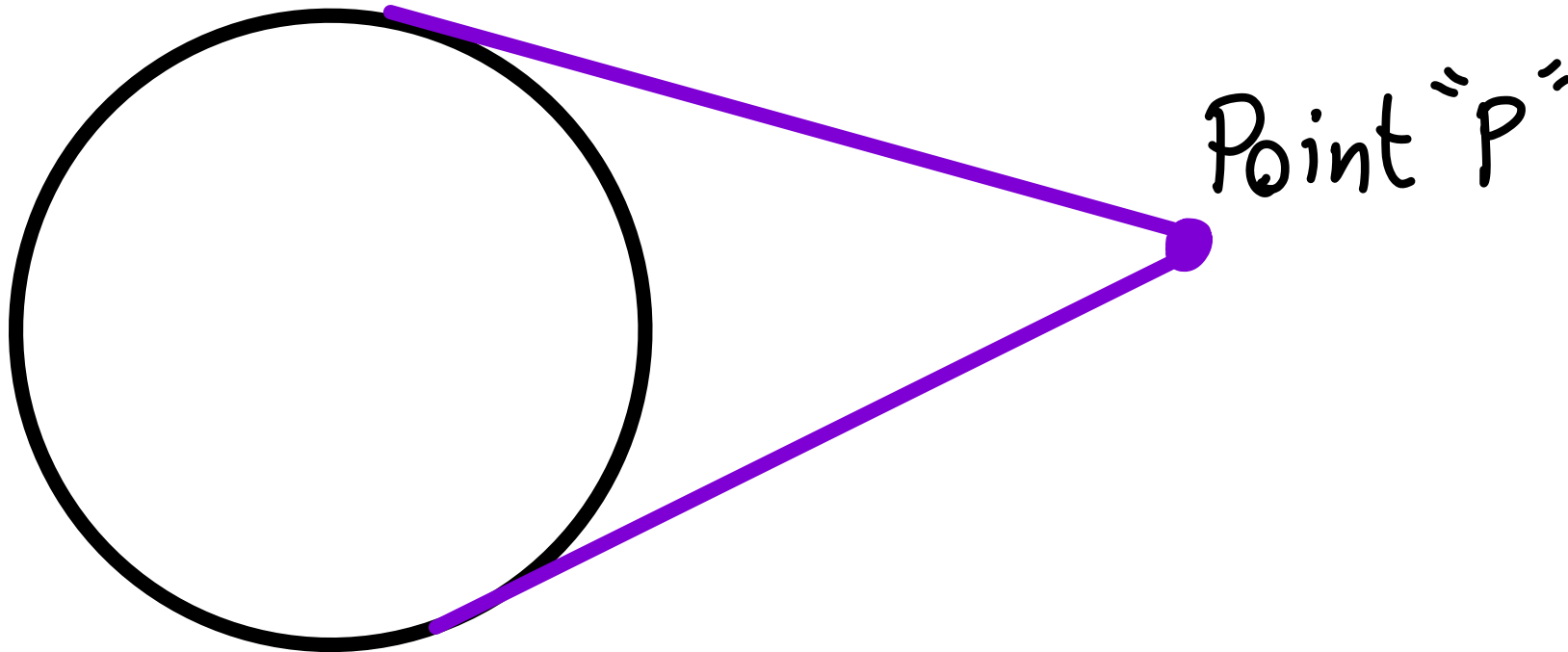

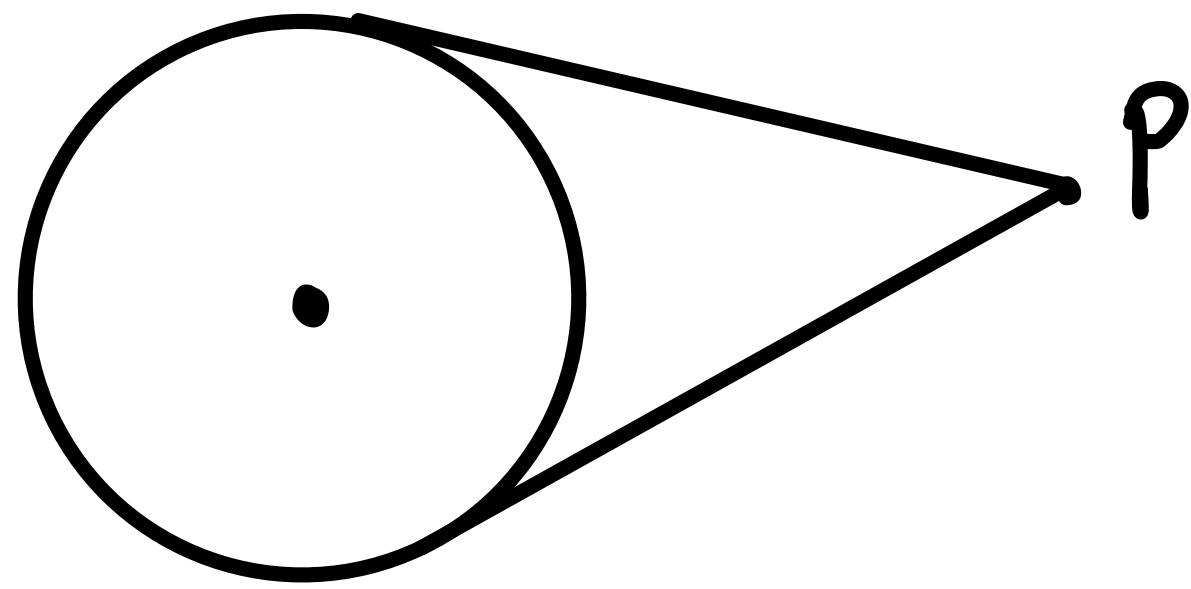
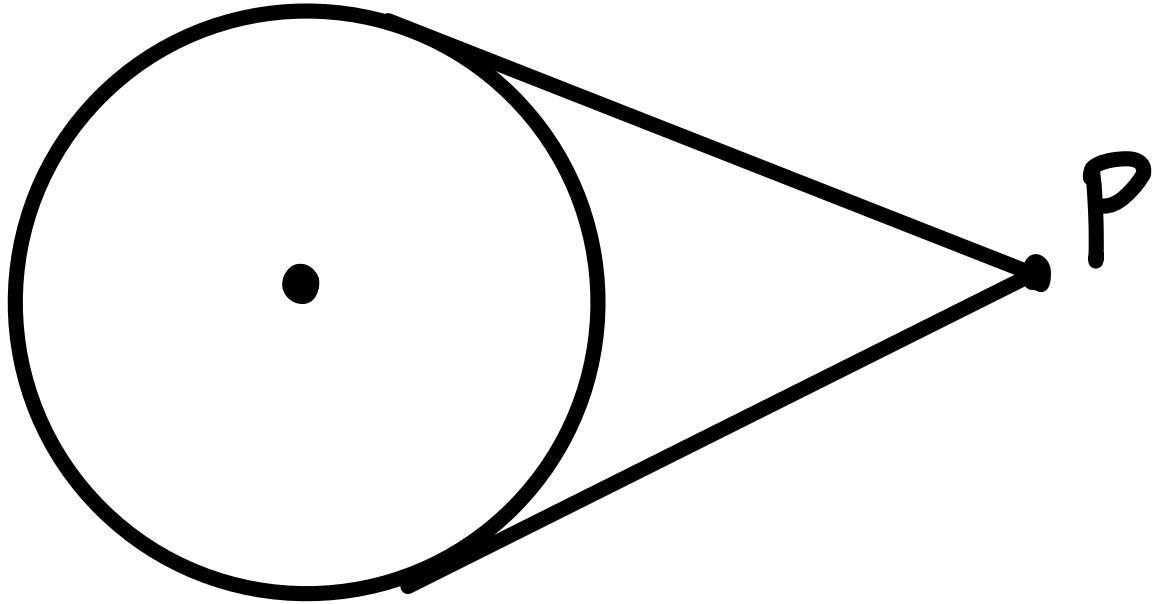

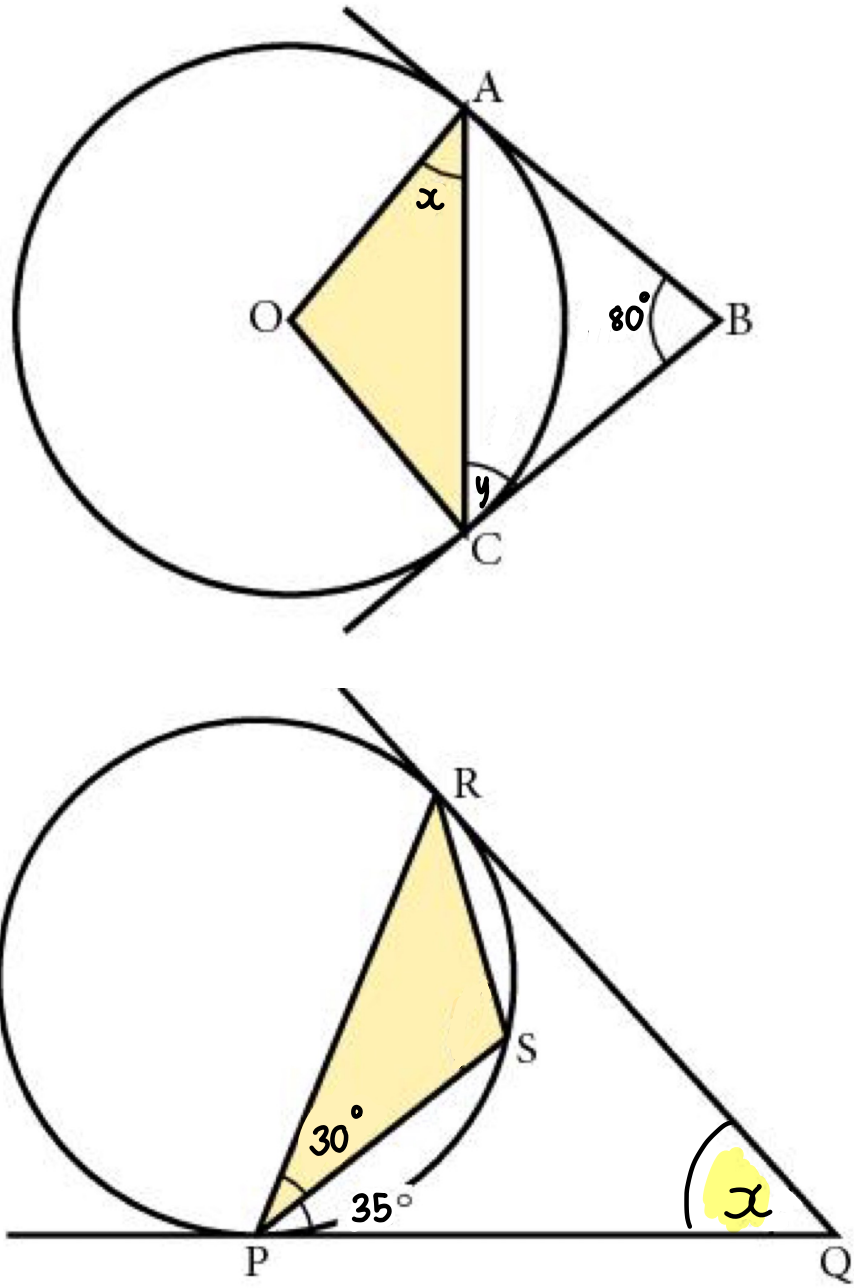

8. Alternate segment theorem

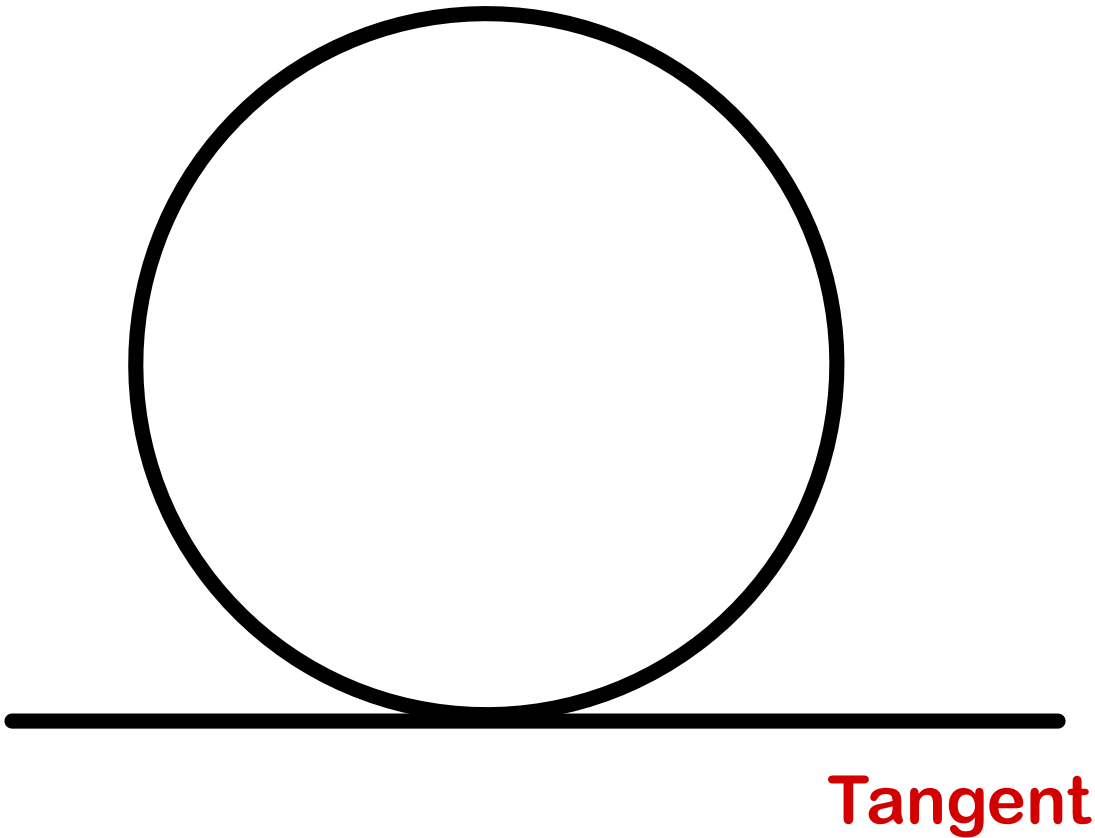

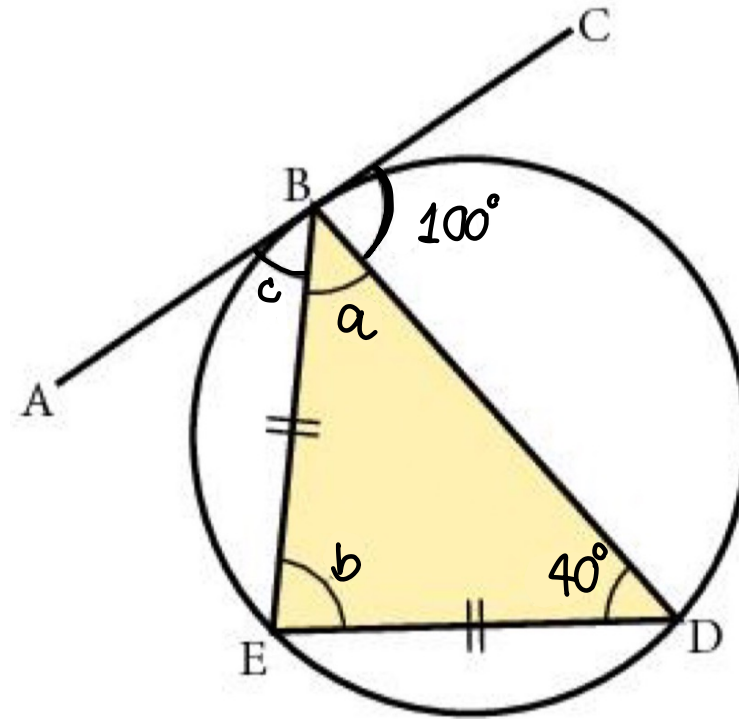
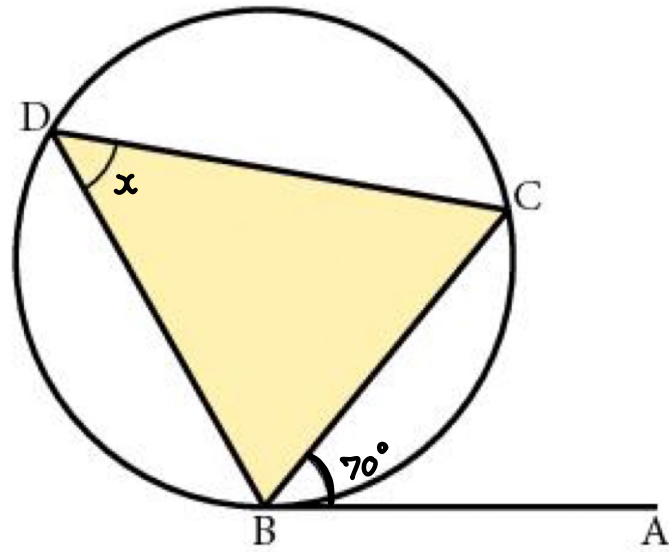

8.

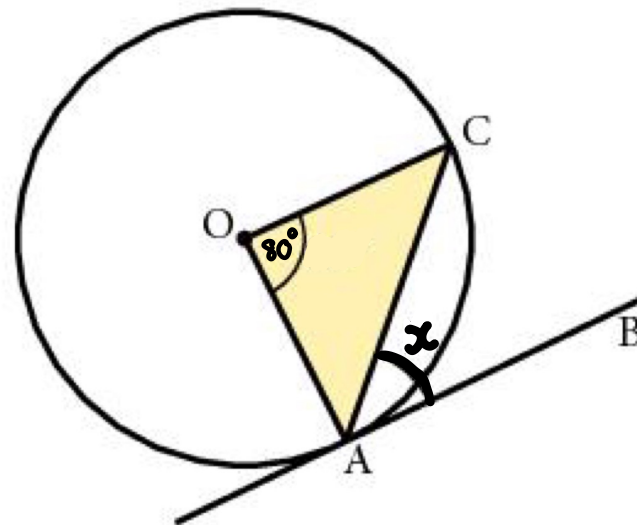

9. A perpendicular line from centre to the chord will bisect chord

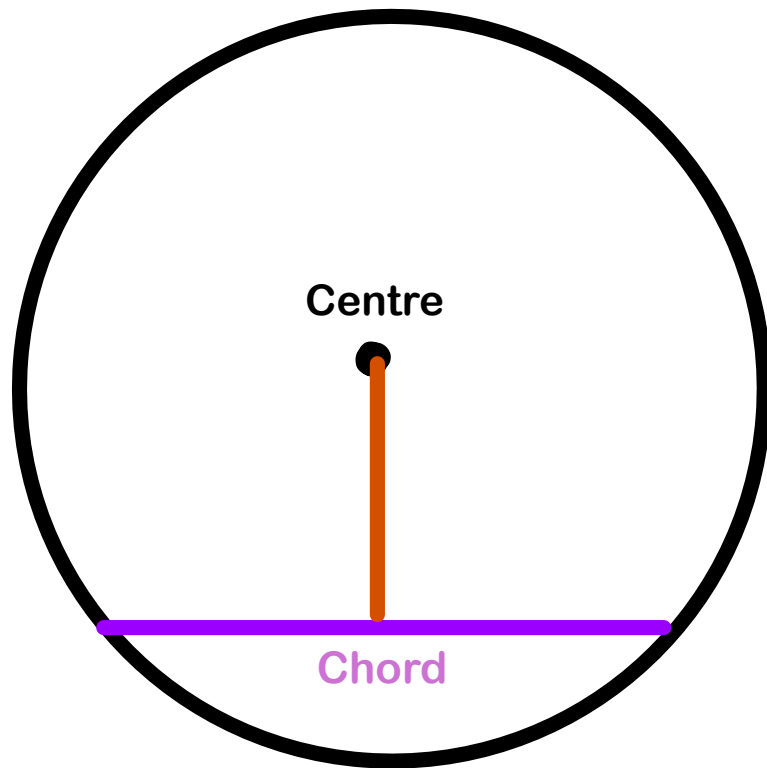

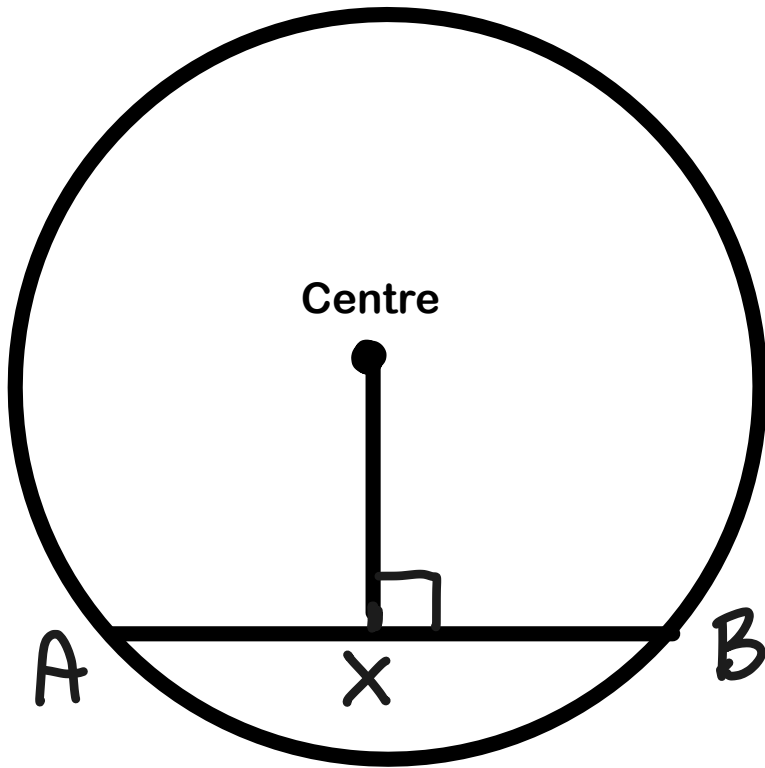

Find length of AX if AB is 10 cm

10. Equal chords of a circle are from the centre

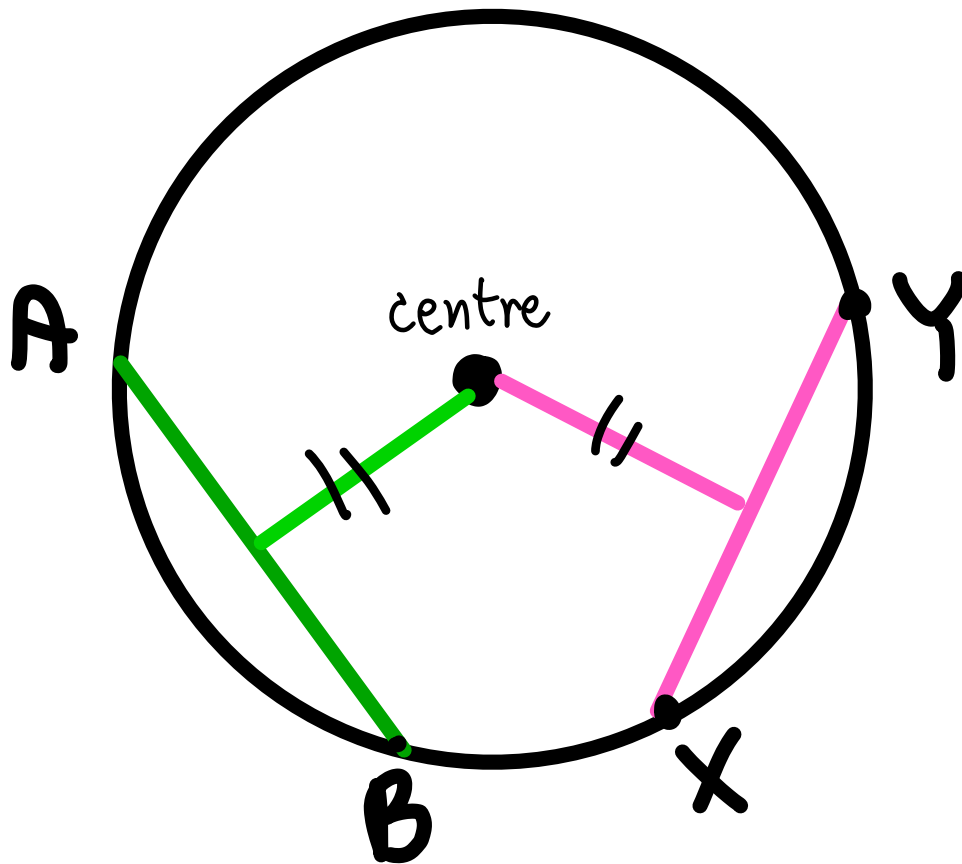

1.

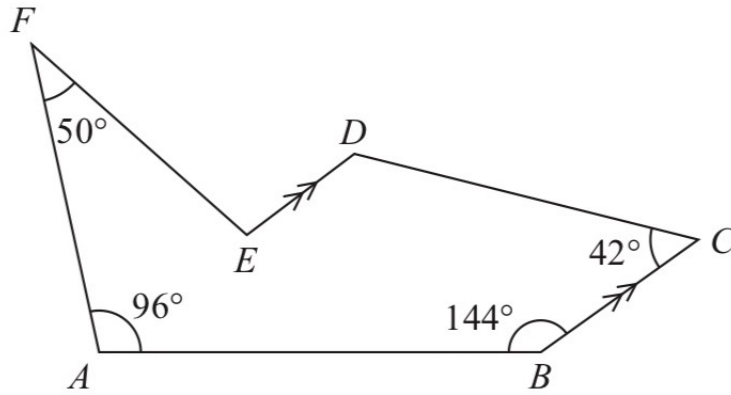

The diagram shows a hexagon $ABCDEF$.
 BC is parallel to ED .

Work out the size of the obtuse angle DEF .

2.

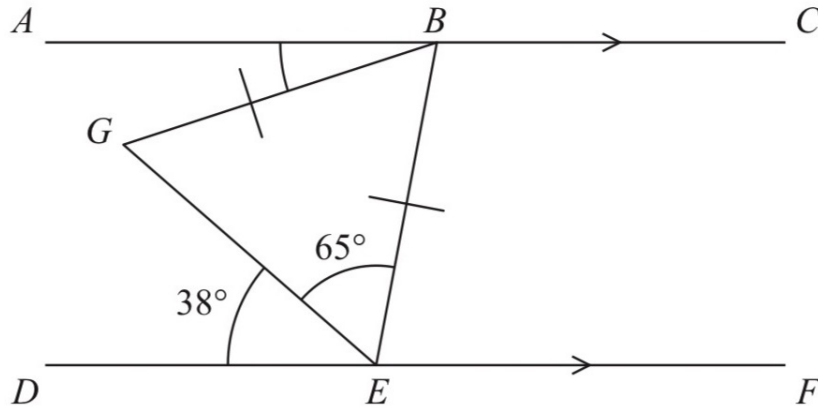

ABC and DEF are parallel lines.

$$BG = BE$$

$$\text{Angle } DEG = 38^\circ$$

$$\text{Angle } GEB = 65^\circ$$

Find the size of angle ABG .

3.

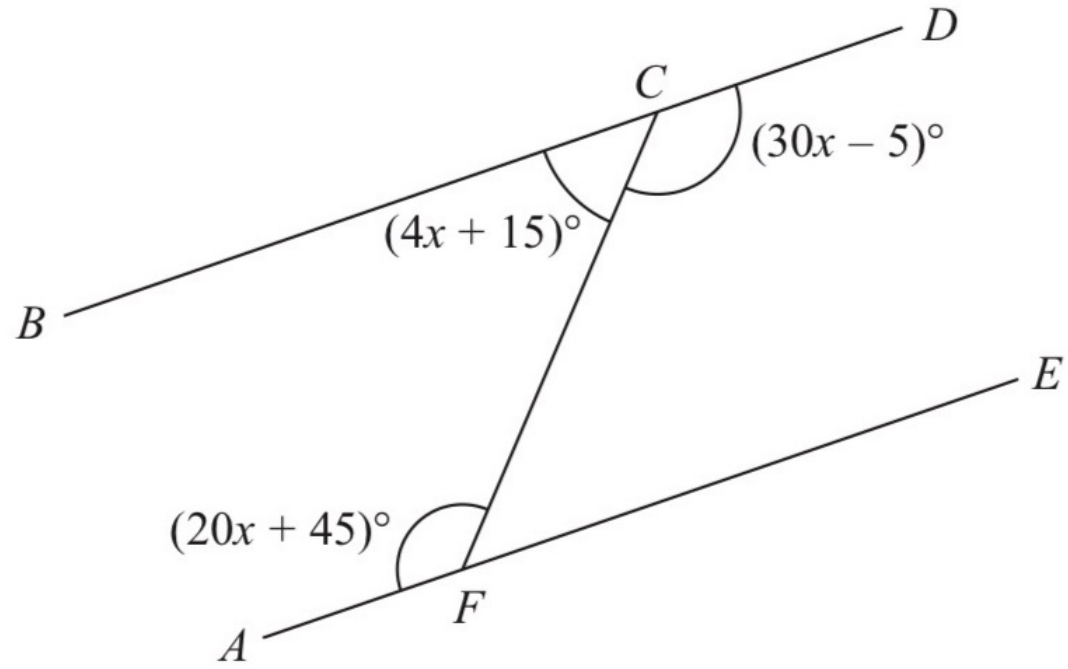

BCD and AFE are straight lines.

Show that BCD is parallel to AFE .

Give reasons for your working.

4.

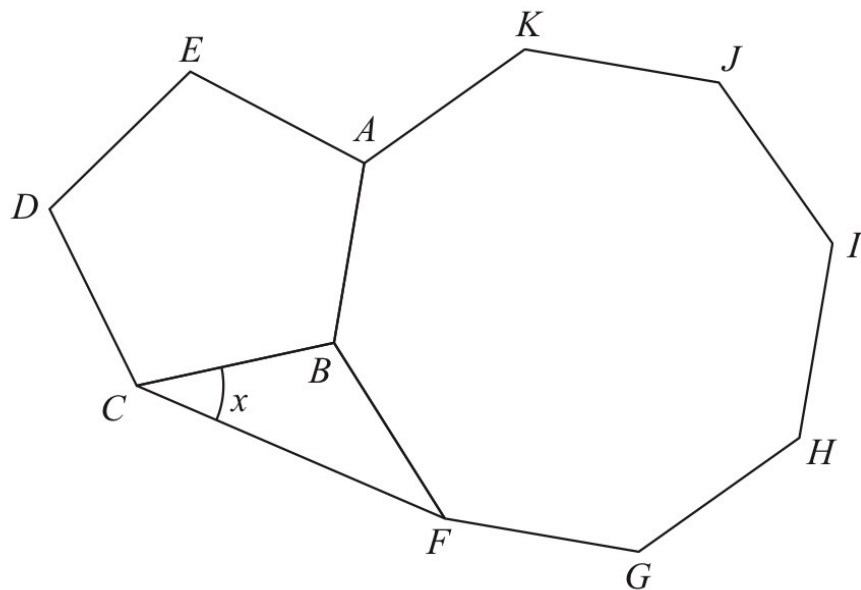
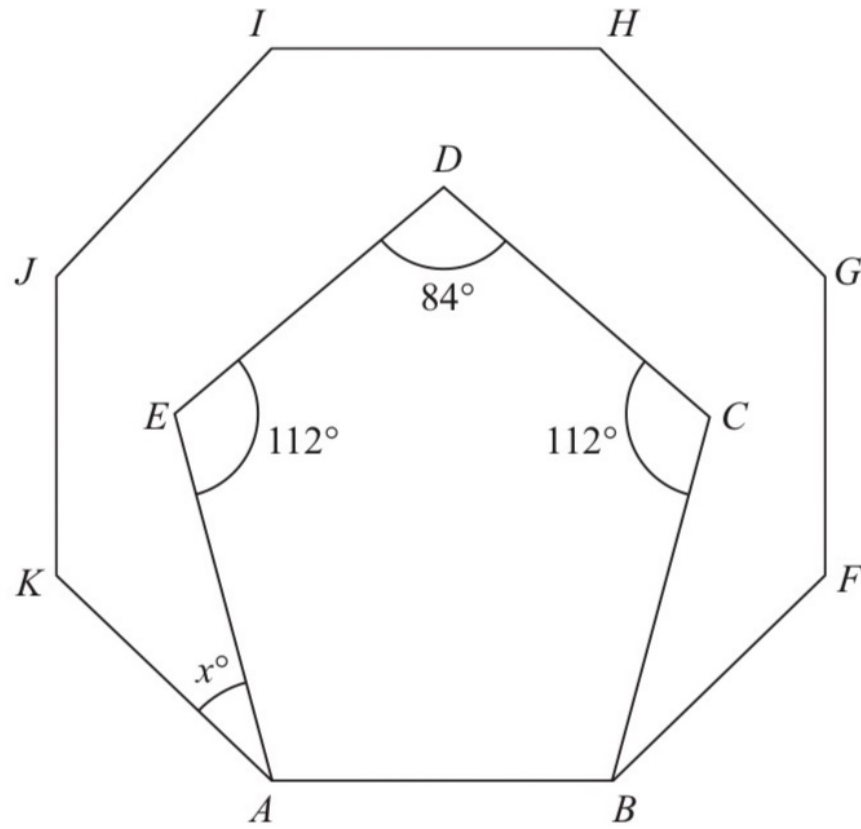

Diagram **NOT**
accurately drawn

The diagram shows a regular pentagon, $ABCDE$, a regular octagon, $ABFGHIJK$, and an isosceles triangle, BCF .

Work out the size of angle x .

5.



Pentagon $ABCDE$ is drawn inside the regular octagon $ABFGHIJK$.
The pentagon has exactly one line of symmetry.

Work out the value of x .

6. The diagram shows a regular octagon $ABCDEFGH$ and a regular pentagon $ABIJK$

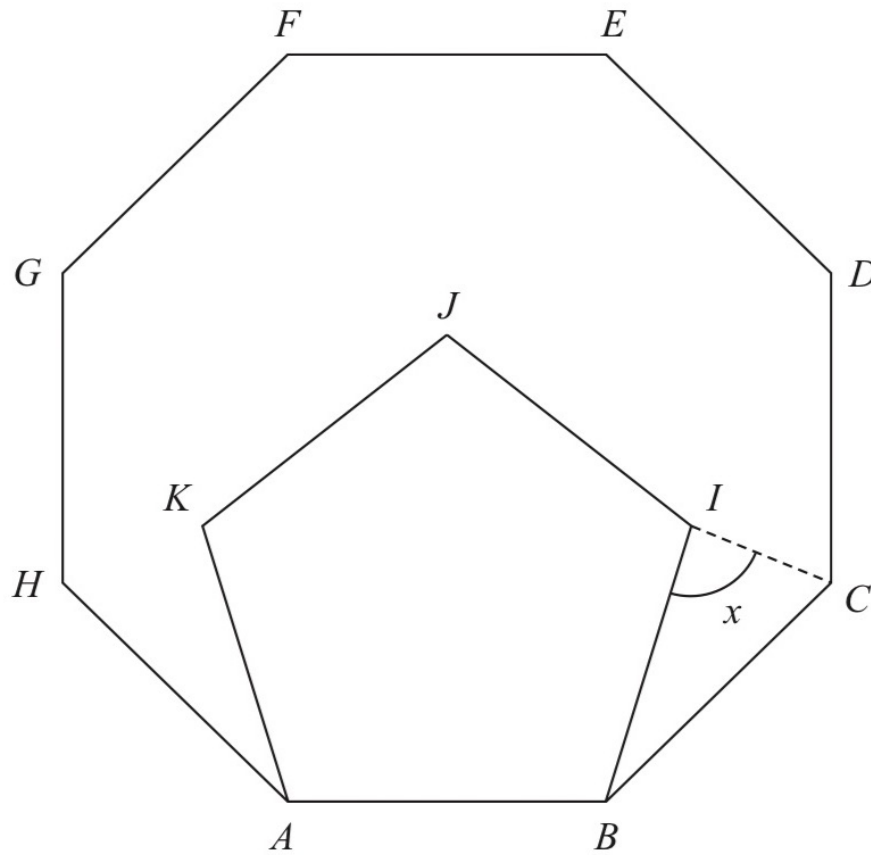
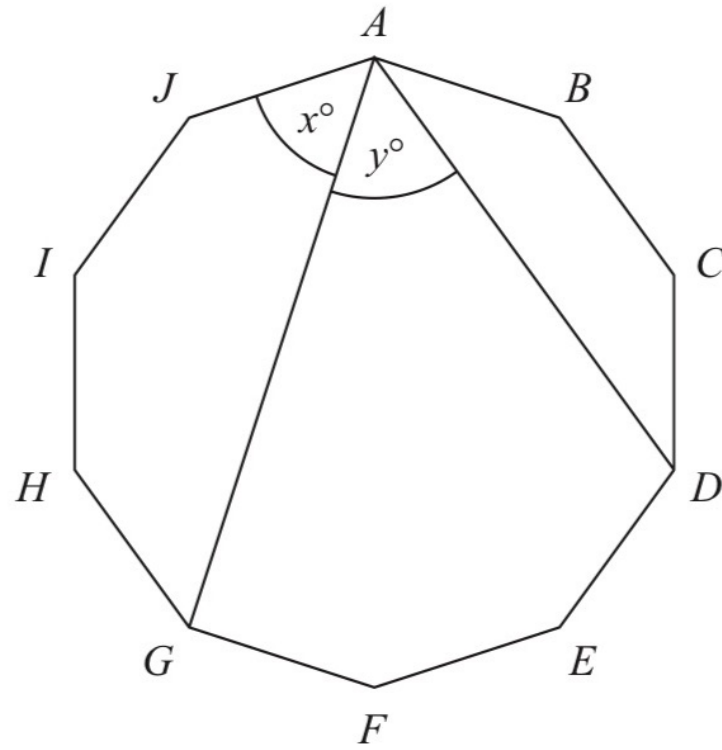

Diagram **NOT**
accurately drawn

Work out the size of the angle x

7.

The diagram shows a regular 10-sided polygon, $ABCDEFGHIJ$



Show that $x = y$

8. The diagram shows two congruent isosceles triangles and parts of two congruent regular polygons, **X** and **Y**.

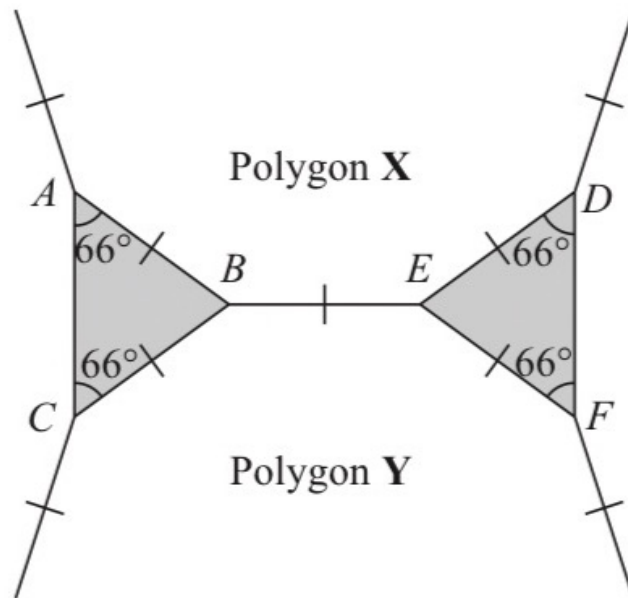
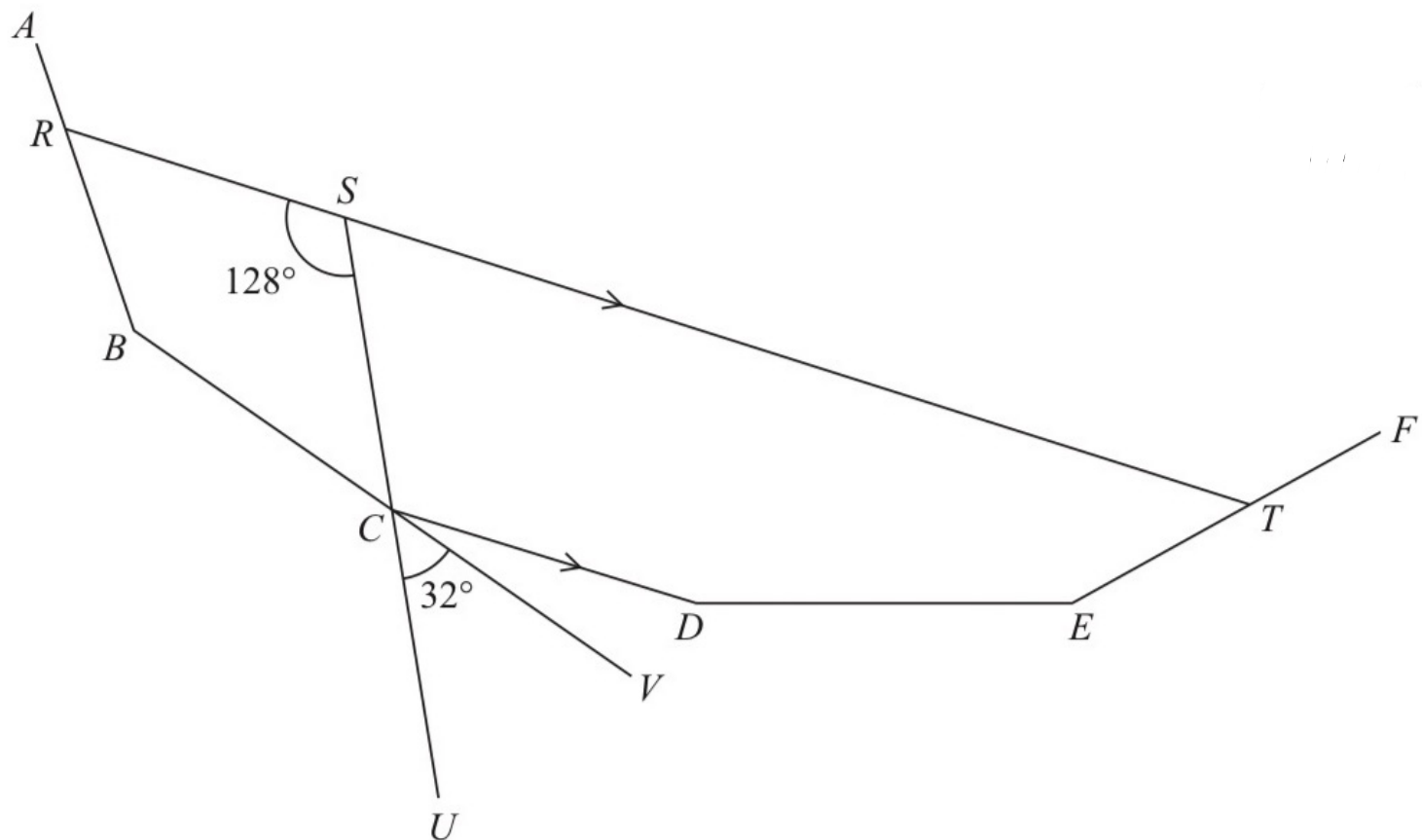

Diagram **NOT**
accurately drawn

The two regular polygons each have n sides.

Work out the value of n .

9.



AB , BC , CD , DE and EF are five sides of a regular polygon.

RST , SCU and BCV are straight lines.

RST is parallel to CD

Angle $RSC = 128^\circ$

Angle $UCV = 32^\circ$

Work out how many sides the polygon has.

Show your working clearly.

10.

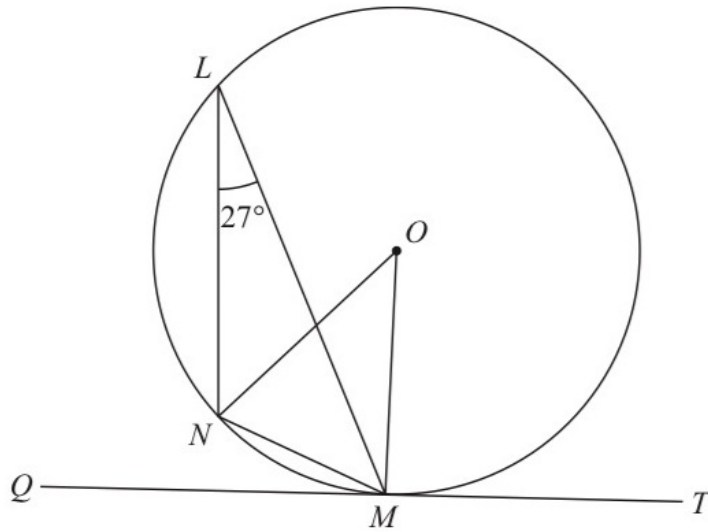

Diagram **NOT** accurately drawn

L , M and N are points on a circle, centre O .
 QMT is the tangent to the circle at M .

(a) (i) Find the size of angle NOM .

.....
 °

(ii) Give a reason for your answer.

.....

 (2)

(b) (i) Find the size of angle NMQ .

.....
 °

(ii) Give a reason for your answer.

.....

 (2)

11. In the diagram below, P and Q are points on a circle with centre O .

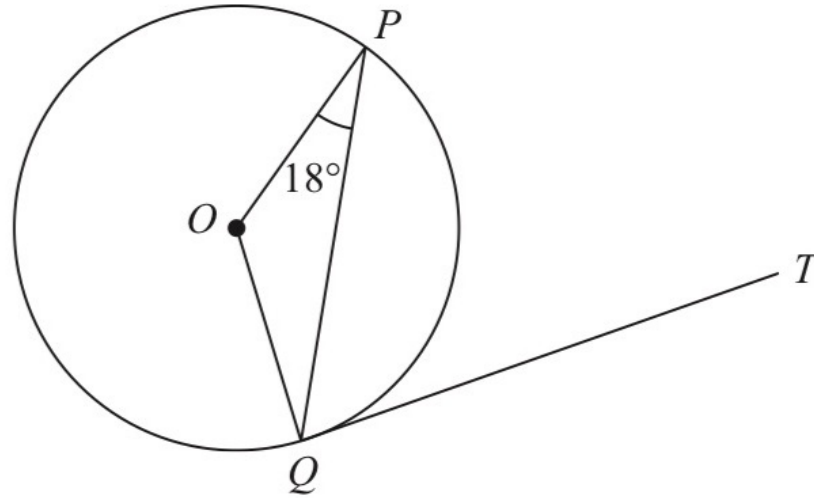

QT is a tangent to the circle.

Angle $OPQ = 18^\circ$

Work out the size of angle PQT .

Give a reason for each stage of your working.

12.

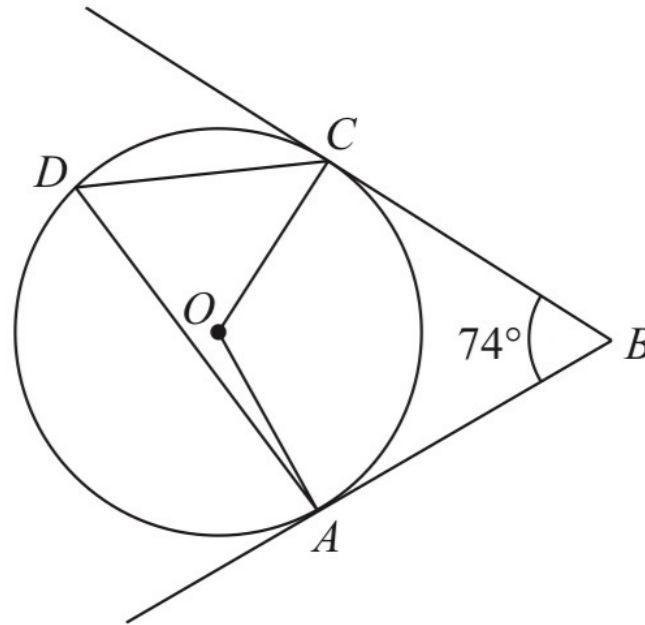

A , C and D are points on a circle, centre O .
 AB and CB are tangents to the circle.

Angle $ABC = 74^\circ$

Work out the size of angle ADC .
Show your working clearly.

13.

Diagram **NOT**
accurately drawn

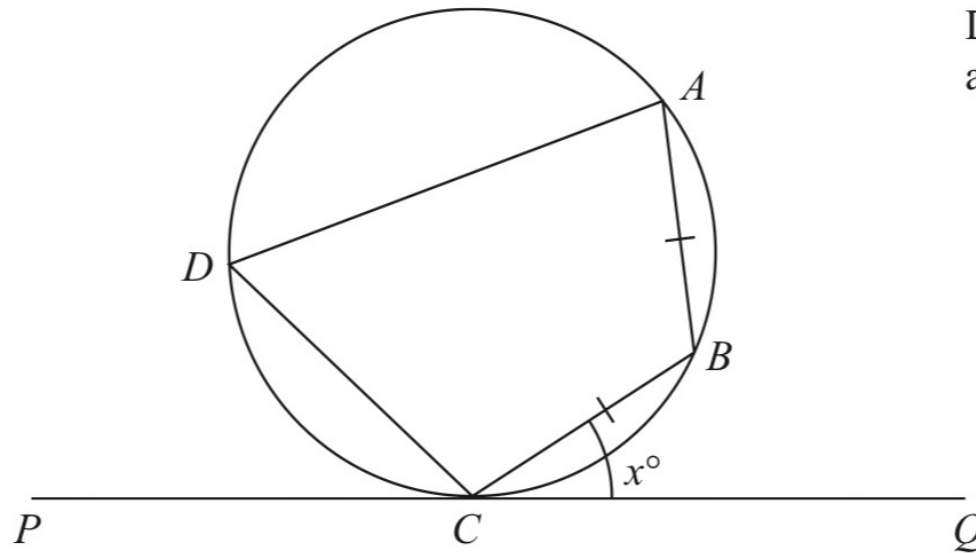

A , B , C and D are points on a circle.

PCQ is a tangent to the circle.

$AB = CB$.

Angle $BCQ = x^\circ$

Prove that angle $CDA = 2x^\circ$

Give reasons for each stage in your working.

14.

Diagram **NOT**
accurately drawn

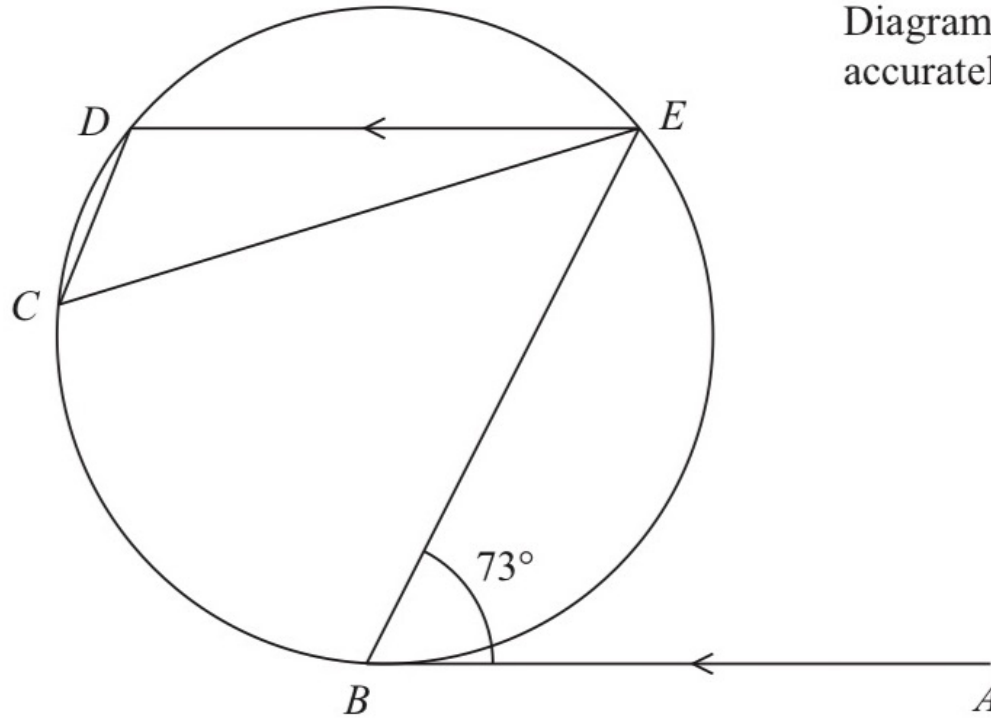

B , C , D and E are points on a circle.

AB is the tangent at B to the circle.

AB is parallel to ED .

Angle $ABE = 73^\circ$

Work out the size of angle DCE .

Give a reason for each stage of your working.

15.

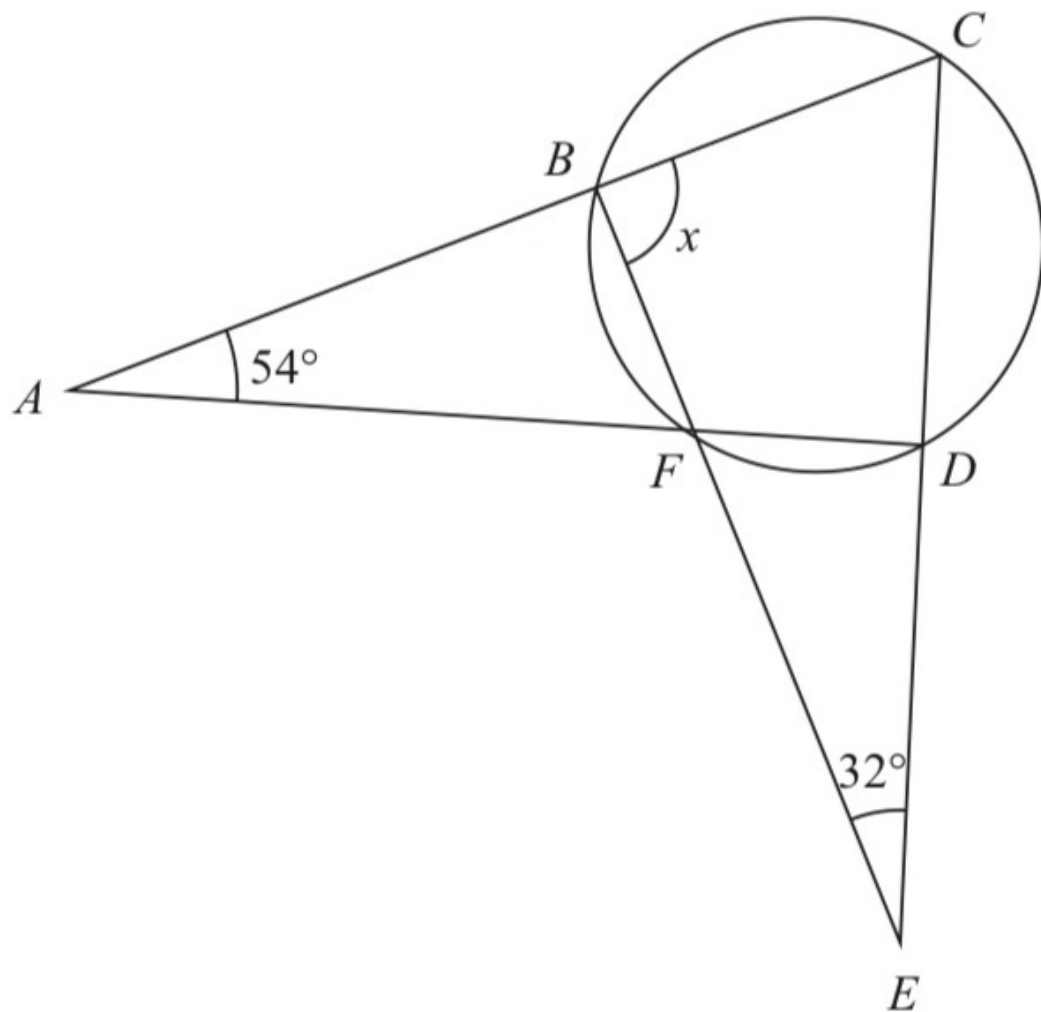

*B, C, D and F are points on a circle.
ABC, AFD, BFE and CDE are straight lines.*

Work out the size of angle x .
Show your working clearly.

16.

Diagram **NOT**
accurately drawn

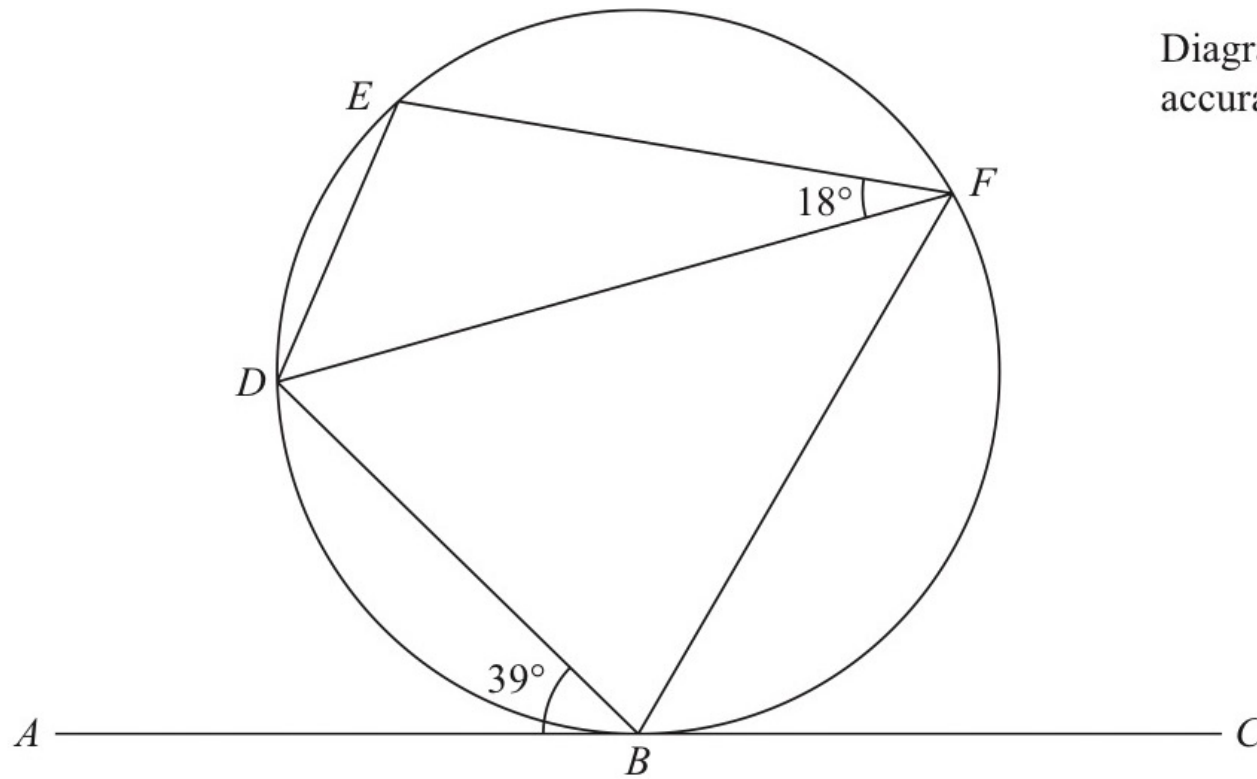

B , D , E and F are points on a circle.

ABC is the tangent at B to the circle.

Angle $ABD = 39^\circ$

Angle $EFD = 18^\circ$

Work out the size of angle BDE .

Give reasons for your working.

17.

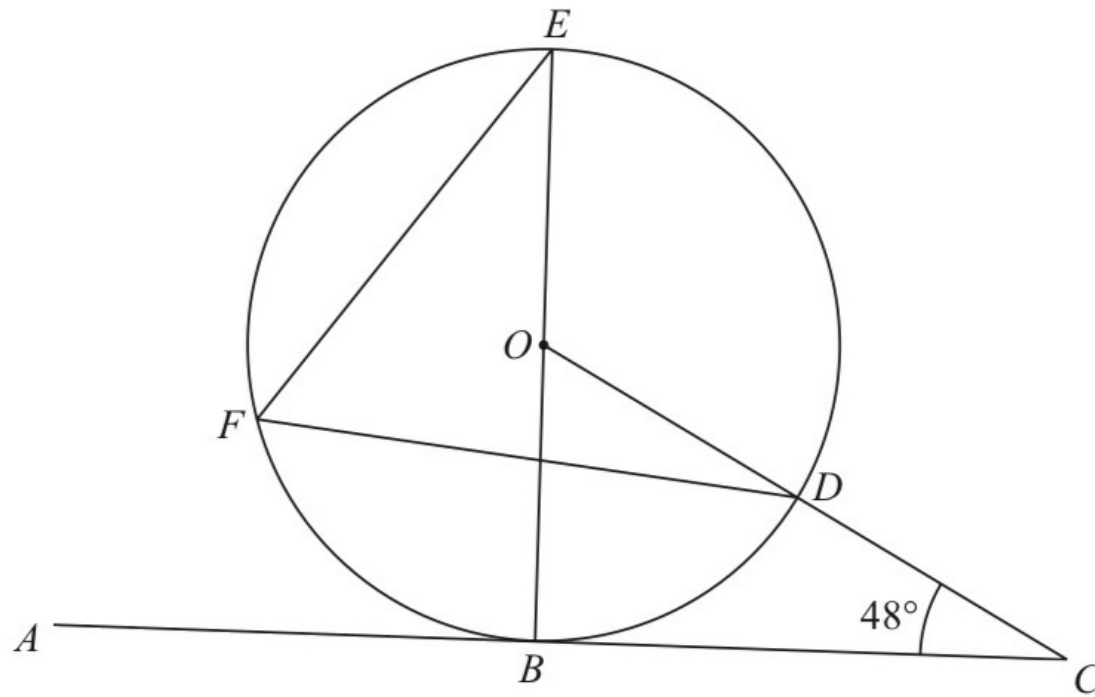

B, D, E and F are points on a circle, centre O .

ABC is a tangent to the circle.

ODC is a straight line.

BOE is a diameter of the circle.

Angle $BCD = 48^\circ$

Find the size of angle DFE .

1. Two chords intersect inside circle

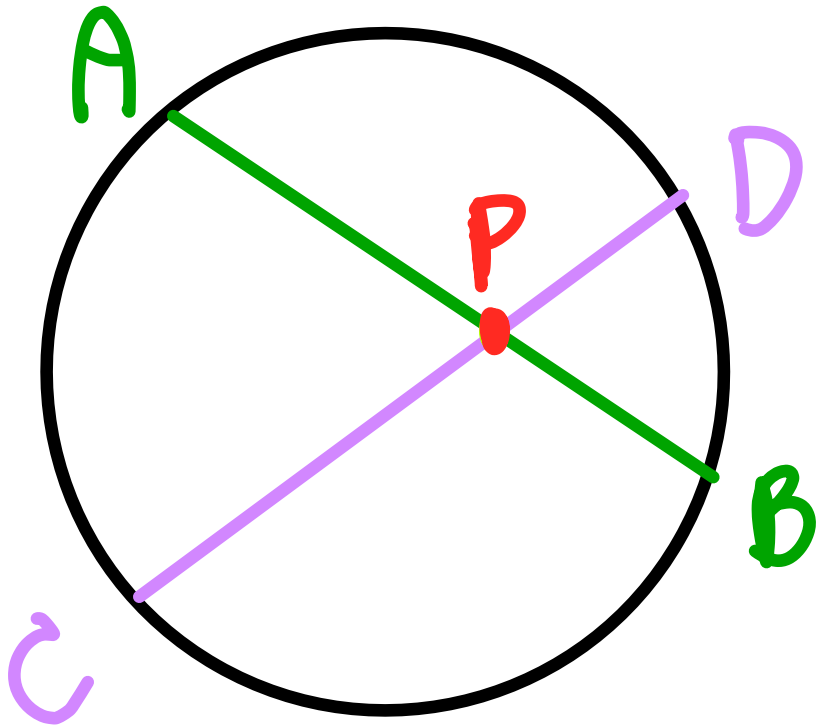

2. Two chords intersect outside circle

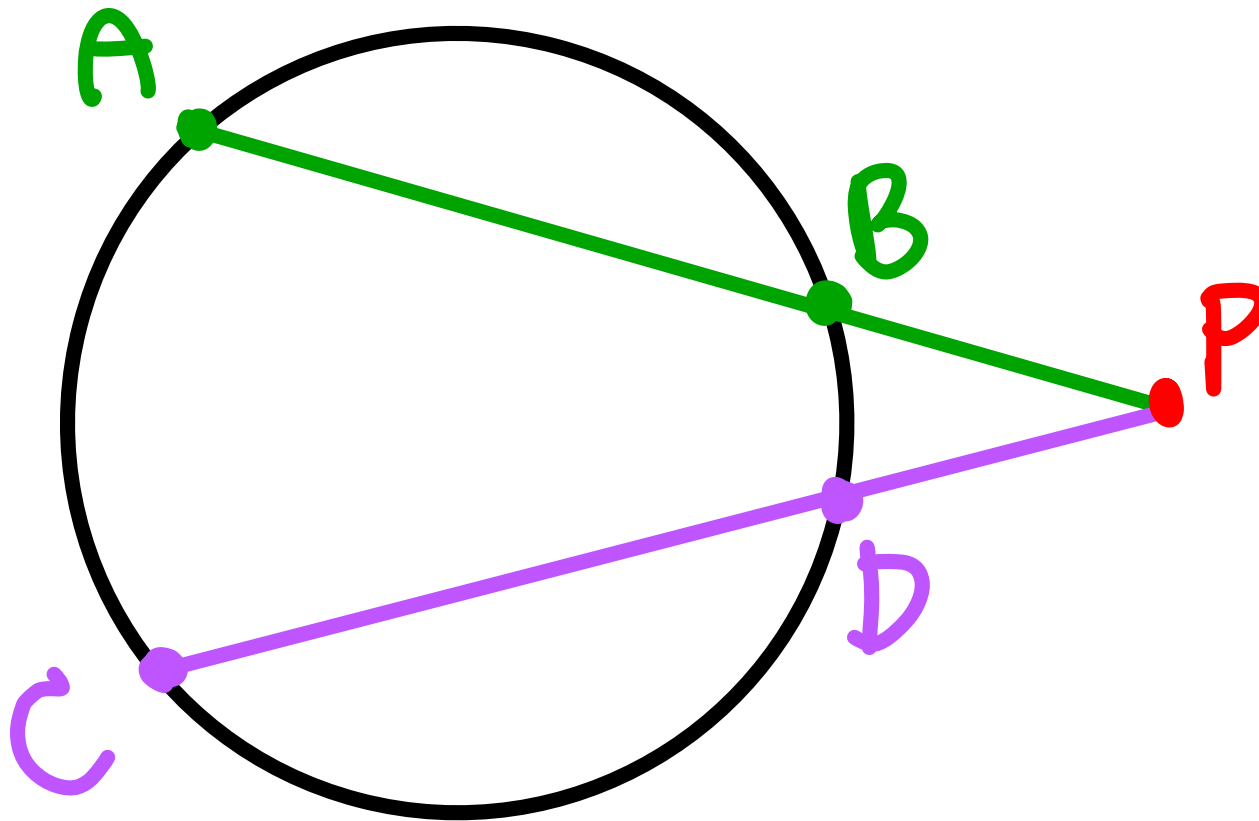

18.

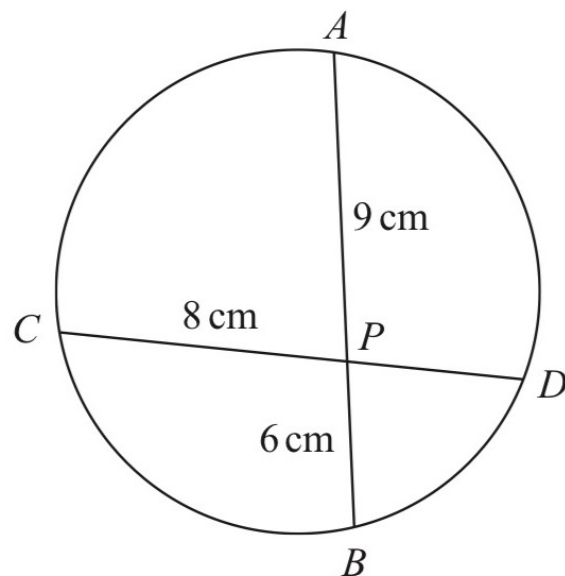

Diagram **NOT**
accurately drawn

APB and CPD are chords of a circle.

$$AP = 9\text{ cm} \quad PB = 6\text{ cm} \quad CP = 8\text{ cm}$$

Calculate the length of PD .

19.

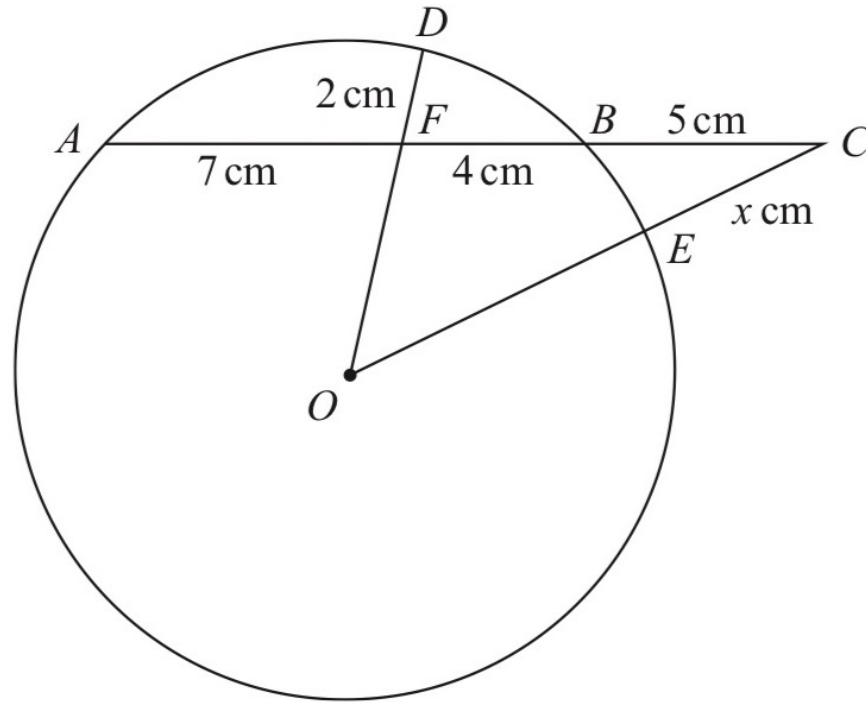

A , D , B and E are points on a circle, centre O .
 $AFBC$, OEC and OFD are straight lines.

$AF = 7$ cm, $FB = 4$ cm, $BC = 5$ cm, $FD = 2$ cm and $CE = x$ cm.

Work out the value of x .
Show your working clearly.

20. A , B , D and E are points on a circle.
 ABC and EDC are straight lines.

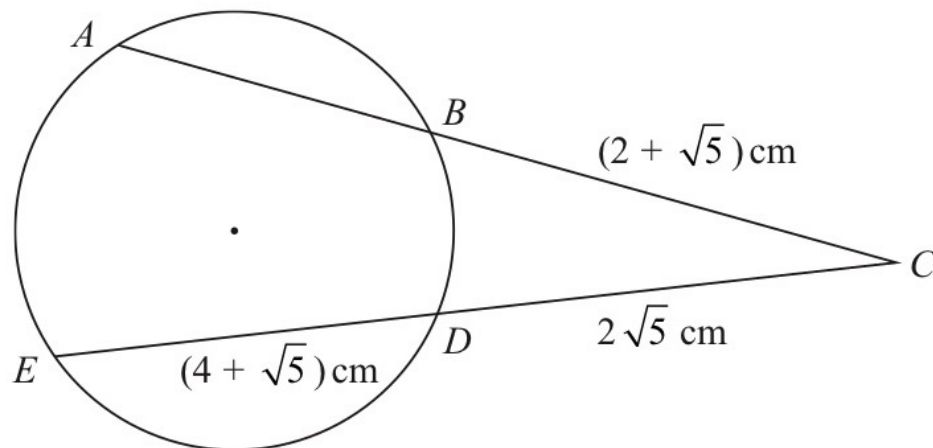

$$BC = (2 + \sqrt{5}) \text{ cm}$$

$$ED = (4 + \sqrt{5}) \text{ cm}$$

$$DC = 2\sqrt{5} \text{ cm}$$

Show that the length of AB is $(p\sqrt{5} + q)$ cm, where p and q are integers whose values are to be found.

Show your working clearly.

Circles and sector



By Kru ชี



Parts of circle

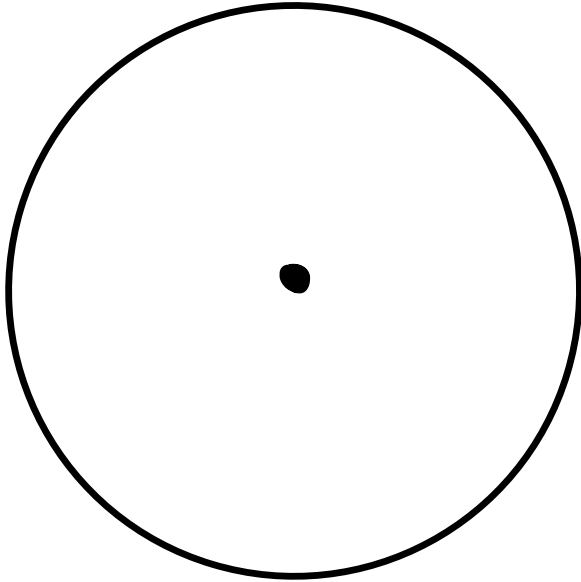

Circumference of circle

Arc length

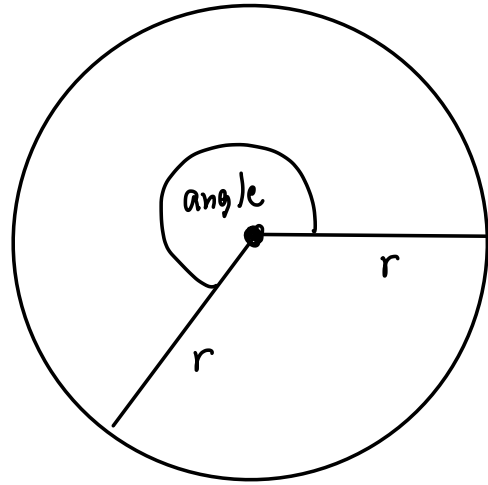
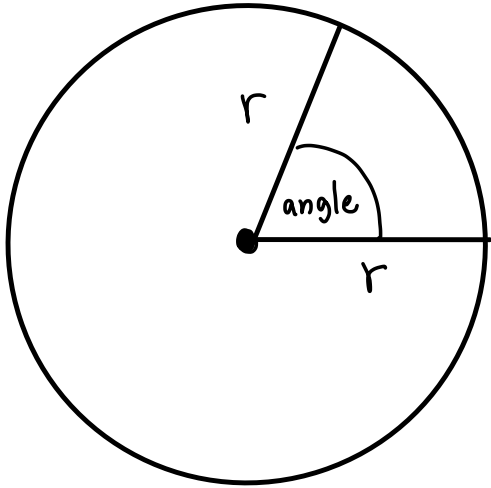

Example

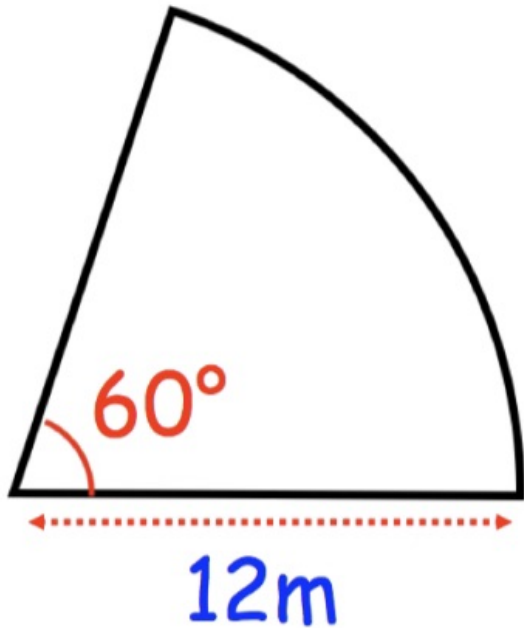

Find the arc length and perimeter

Area of circle

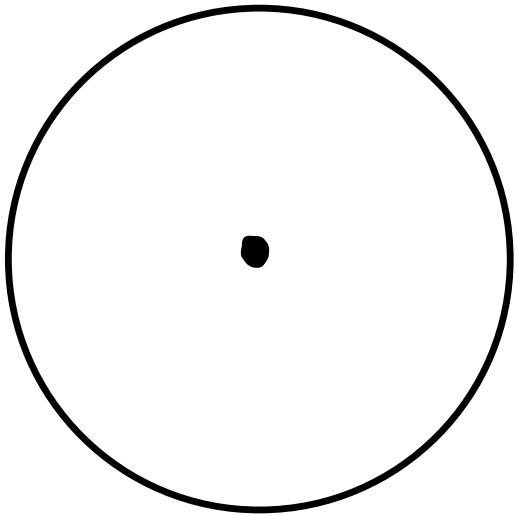

Area of sector

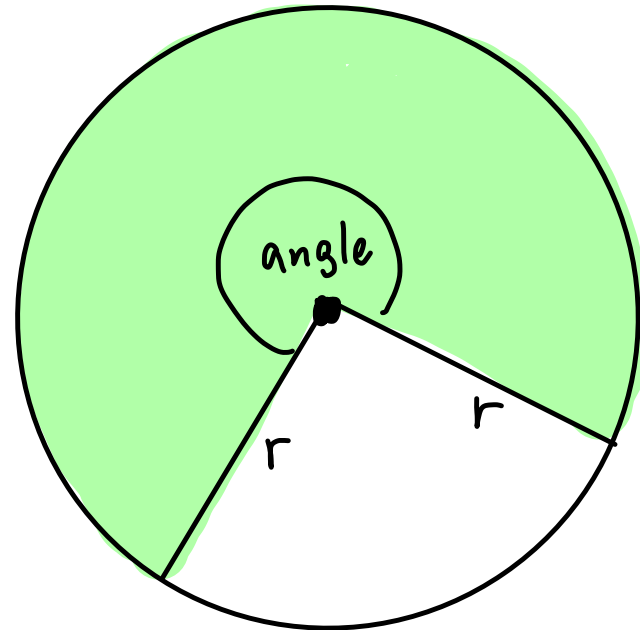
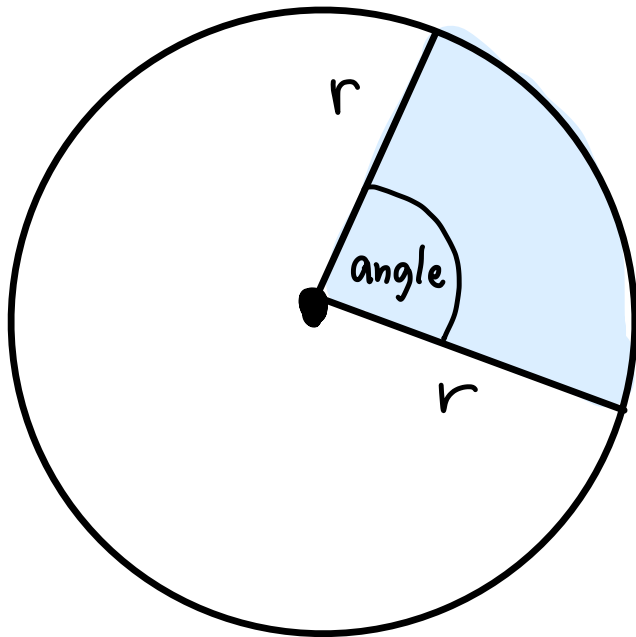

Example

Find the area

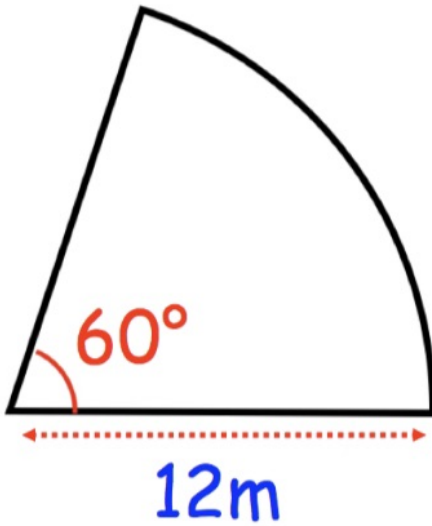



Segment

1. The shape, shown shaded in the diagram, is the region between two semicircles.

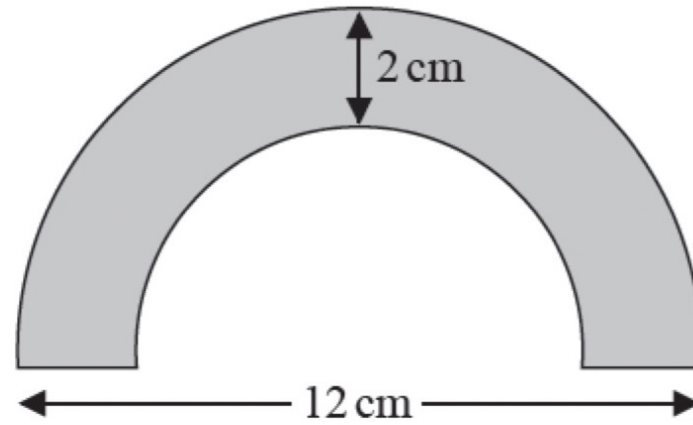
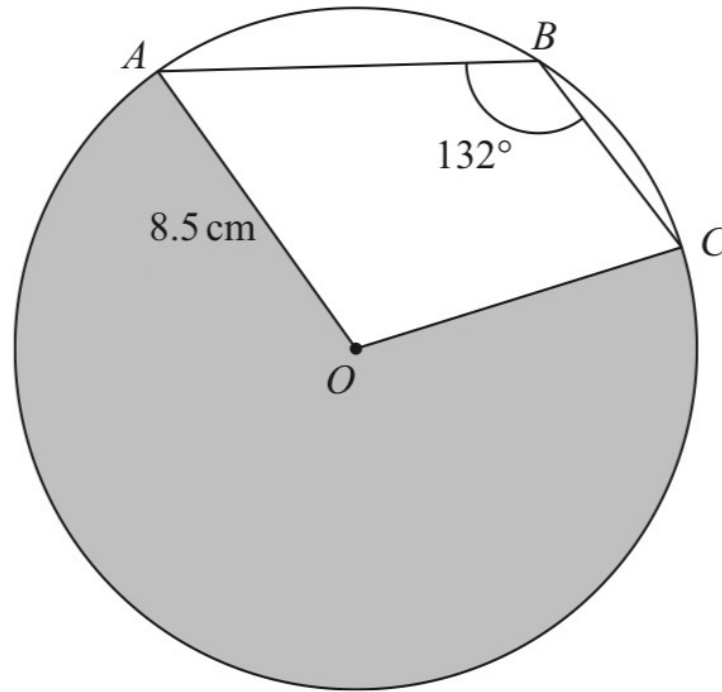

Diagram **NOT**
accurately drawn

The diameter of the outer semicircle is 12 cm.
The shape has constant thickness 2 cm.

Calculate the area of the shape.
Give your answer as a multiple of π .

2. A , B and C are points on a circle, centre O



The radius of the circle is 8.5 cm

Angle $ABC = 132^\circ$

Work out the perimeter of the shaded sector AOC

Give your answer correct to 3 significant figures.

3. A circle centre O has radius 9 cm.

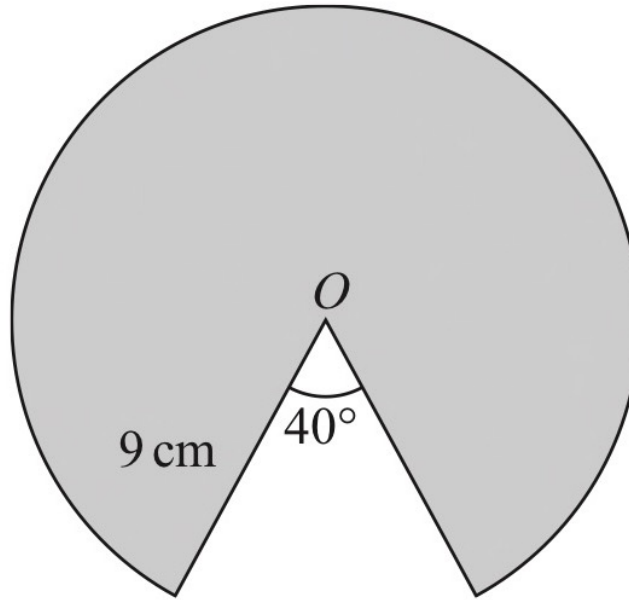

Calculate the perimeter of the shaded sector of the circle.
Give your answer correct to 3 significant figures.

4. The diagram shows a circle with centre O

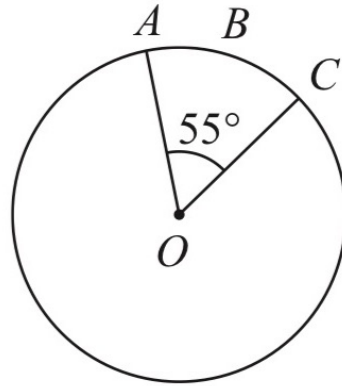

A , B and C are points on the circle so that the length of the arc ABC is 5 cm.

Given that angle $AOC = 55^\circ$

work out the area of the circle.

Give your answer correct to one decimal place.

5.

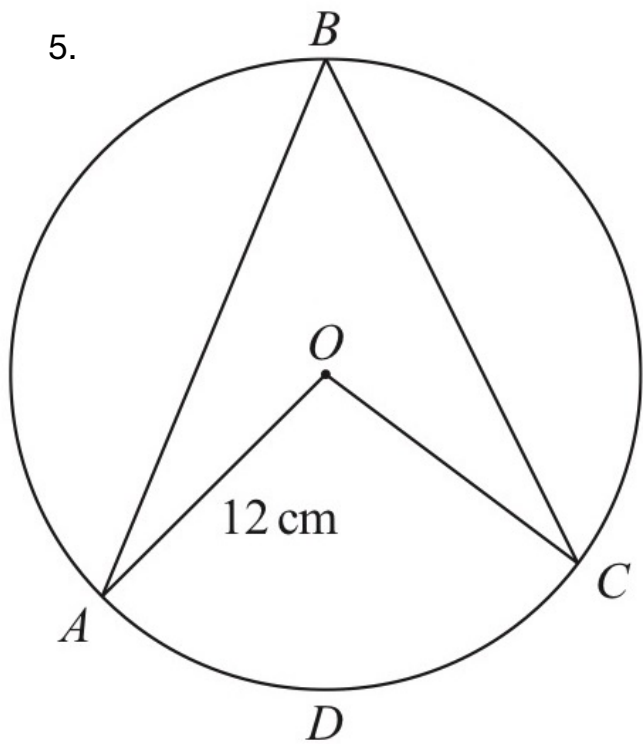

A , B , C and D are points on a circle with centre O and radius 12 cm .

The area of the sector $OADC$ of the circle is 100 cm^2

Work out the size of angle ABC .

Give your answer correct to 3 significant figures.

6.

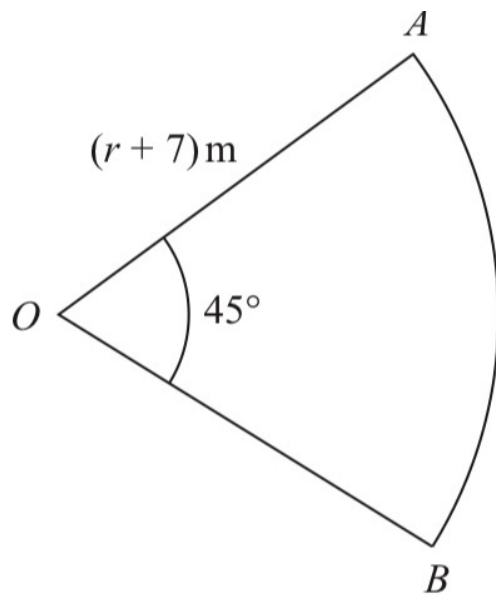

OAB is a sector S of a circle with centre O and radius $(r + 7)$ metres.
Angle $AOB = 45^\circ$

A circle C has radius $(r - 2)$ metres.

The area of sector S is twice the area of circle C

Find the value of r

Show your working clearly.

7. The diagram shows a sector $OAPB$ of a circle, centre O .

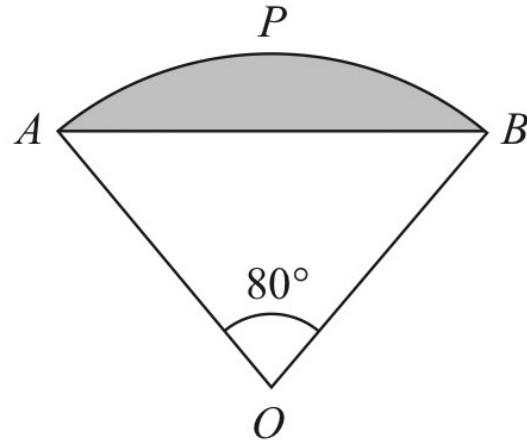

AB is a chord of the circle.

Angle $AOB = 80^\circ$

The area of sector $OAPB$ is $\frac{25}{2}\pi \text{ cm}^2$

Work out the perimeter of the shaded segment.

Give your answer correct to 3 significant figures.

8. A , B and C are points on a circle with centre O .

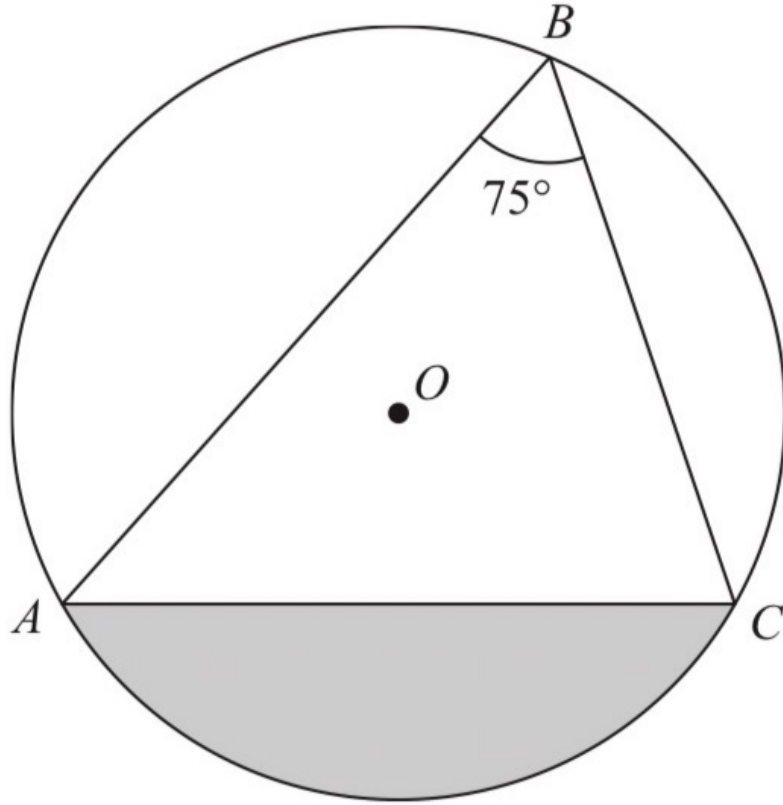

Angle $ABC = 75^\circ$

The area of the shaded segment is 200 cm^2

Calculate the radius of the circle.

Give your answer correct to 3 significant figures.

9.

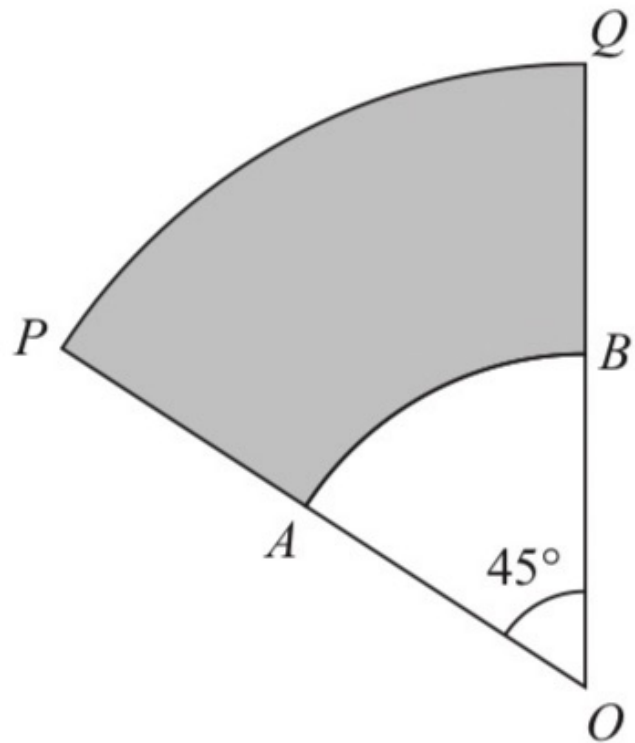

OPQ is a sector of a circle, centre O

OAB is a sector of a circle, centre O

A is the point on OP such that $OA : AP = 3 : 2$

B is the point on OQ such that $OB : BQ = 3 : 2$

Angle $POQ = 45^\circ$

The area of the shaded region is $\frac{81}{2}\pi \text{ cm}^2$

Work out the perimeter of the shaded region.

Give your answer in terms of π .



Mensuration

(Perimeter , area , volume)



By Kru ชี

 Perimeter is the total distance around the 2D shapes

 Area is the region inside 2D shapes

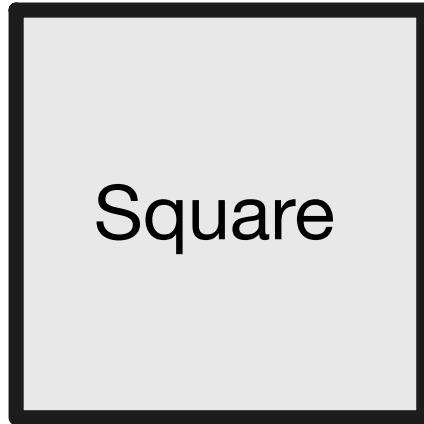



Rectangle



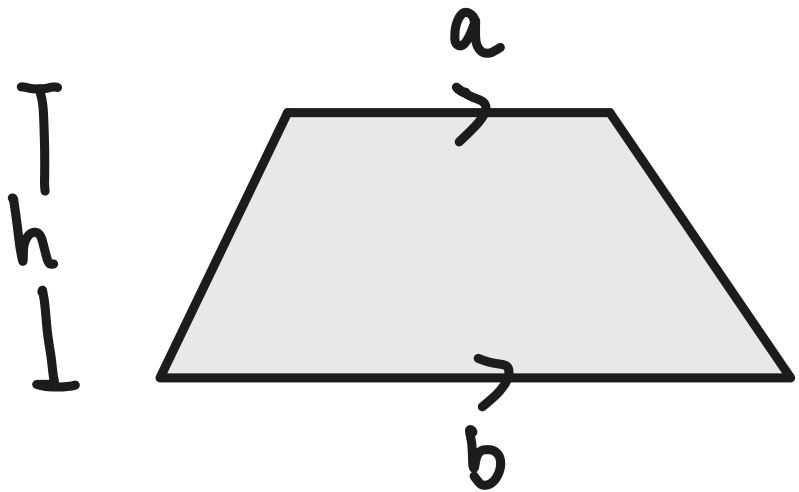

Cube

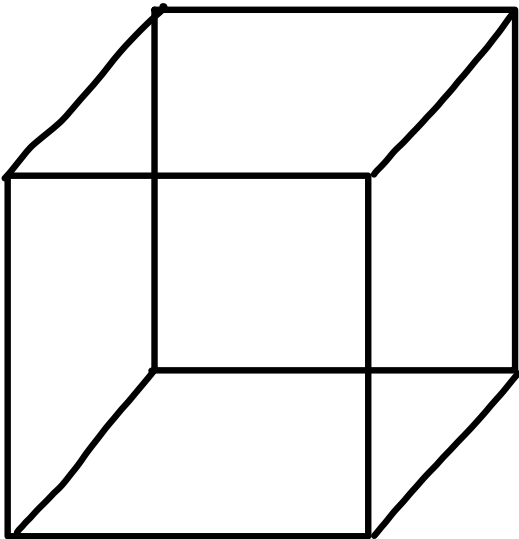

Example

Find the total surface area

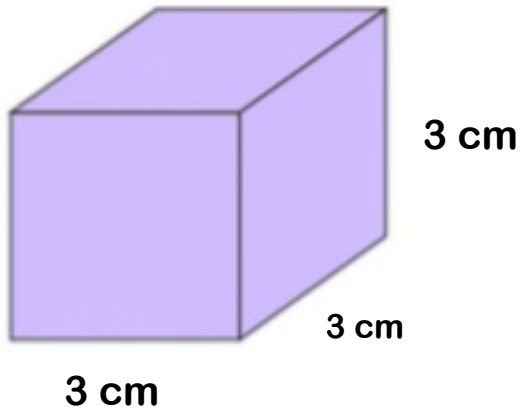

Cuboid

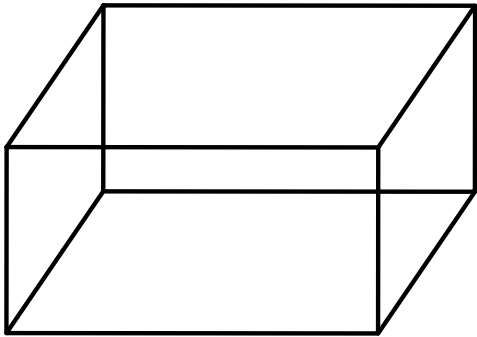

Example

Find the total surface area

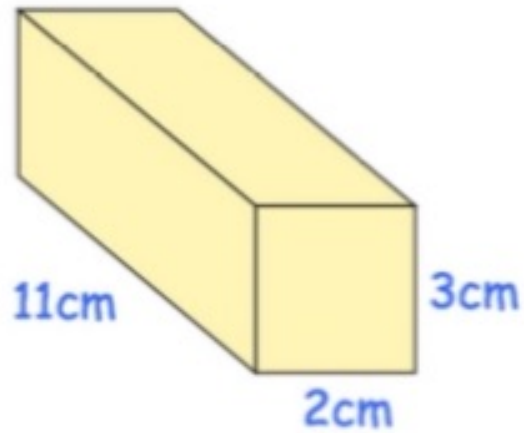

Prisms

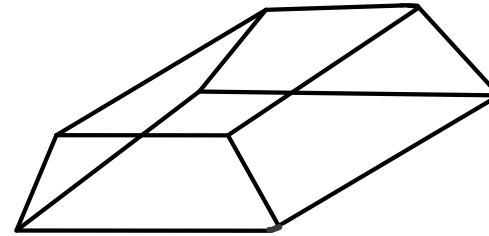
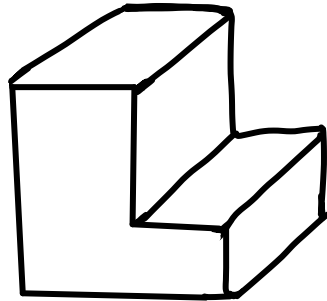
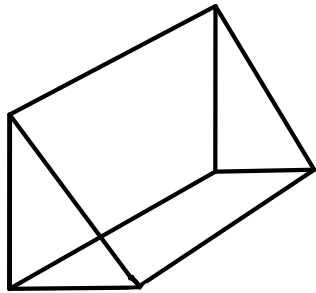

Example

Find the total surface area

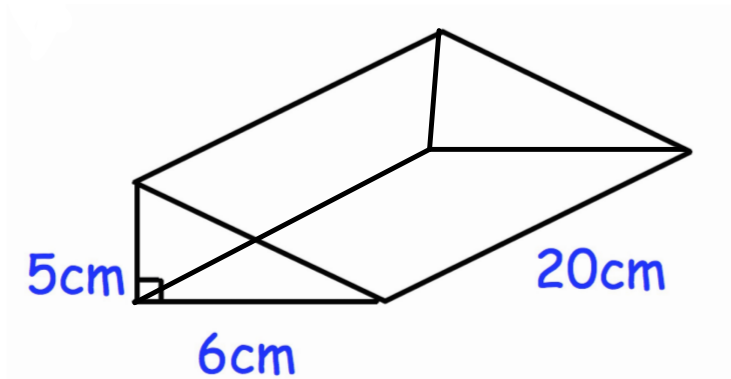

Example

Find the total surface area

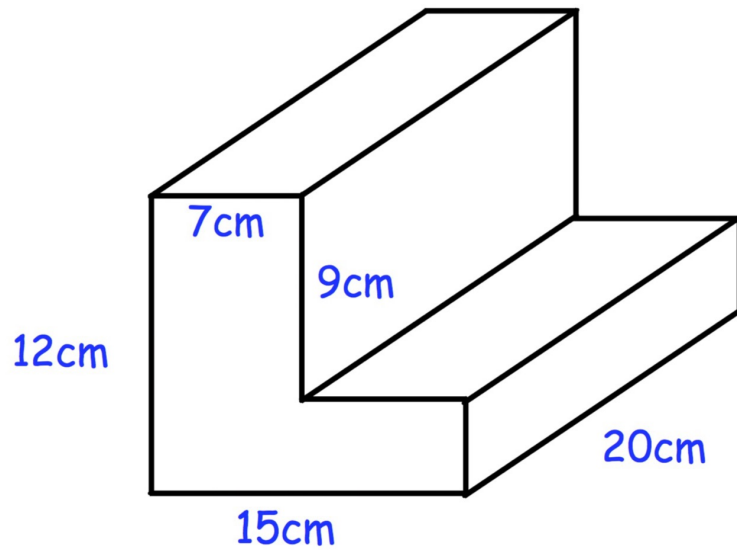

Cylinder

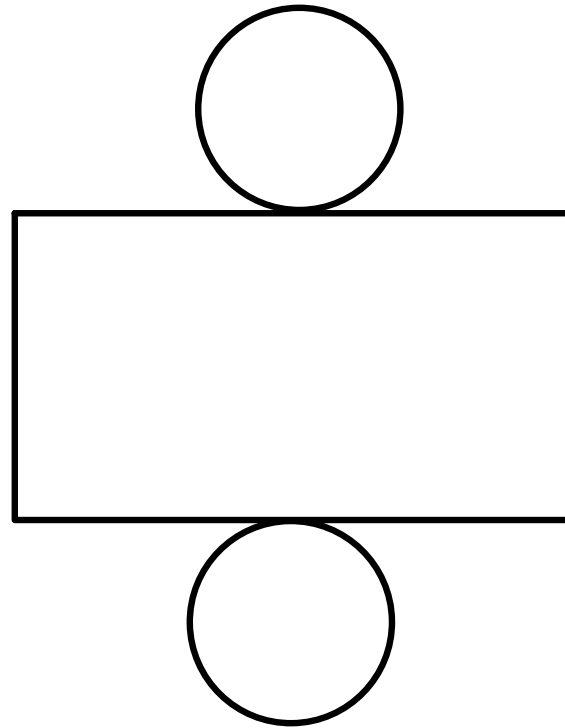
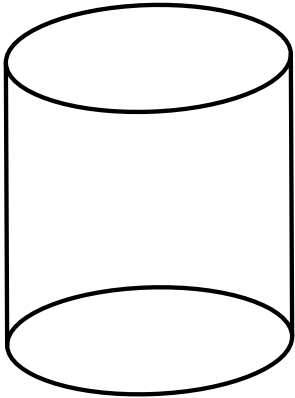

Example

Find the total surface area

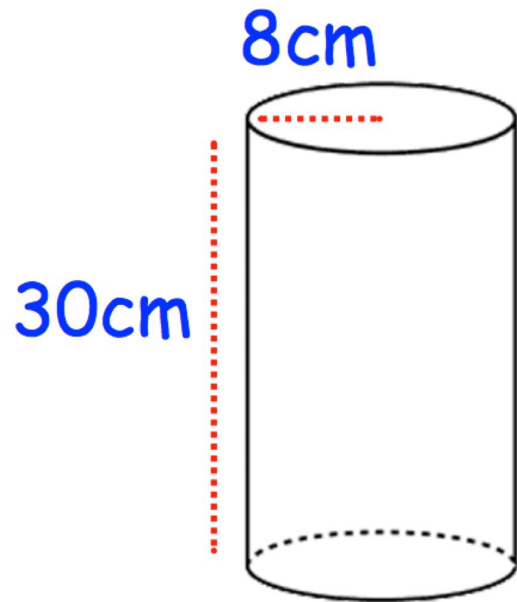

Example

Find the total surface area

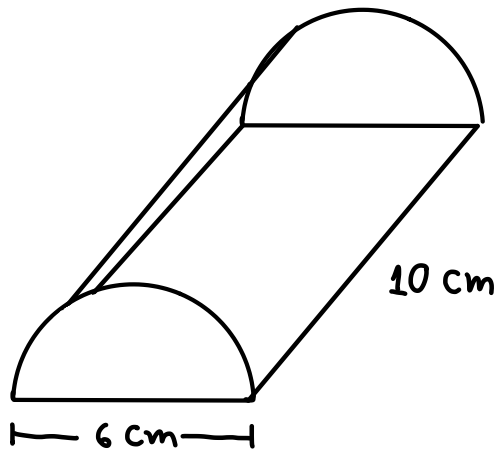

Cone

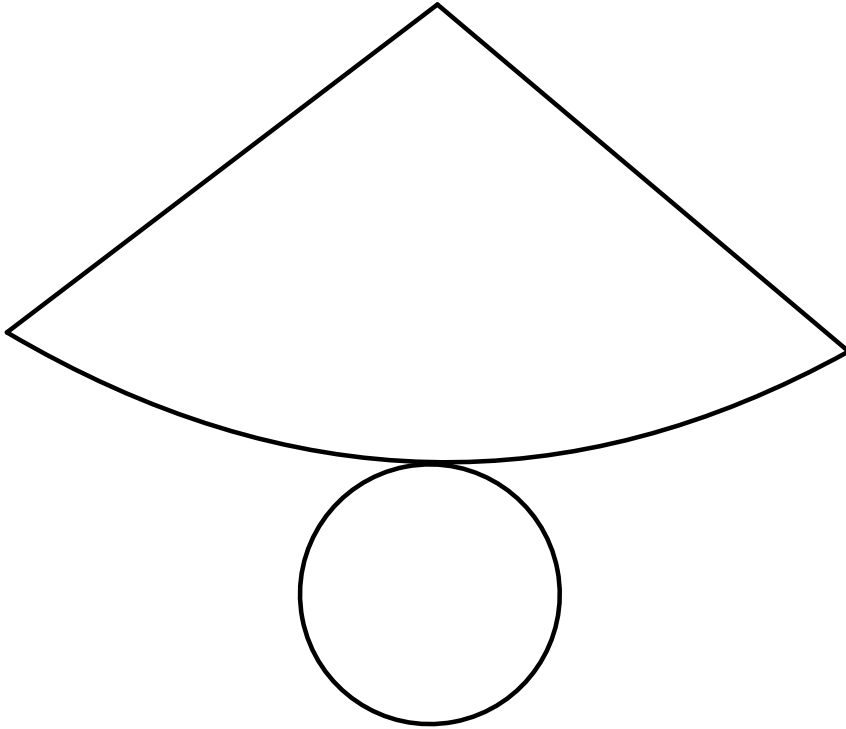
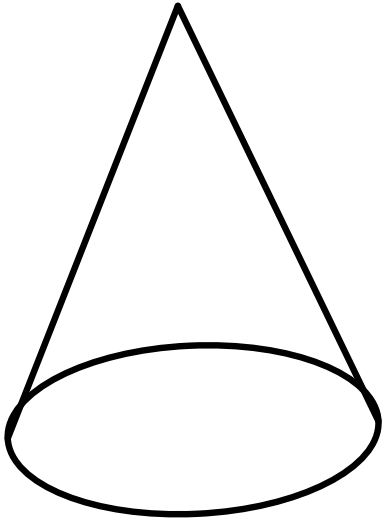

Example

Find the total surface area

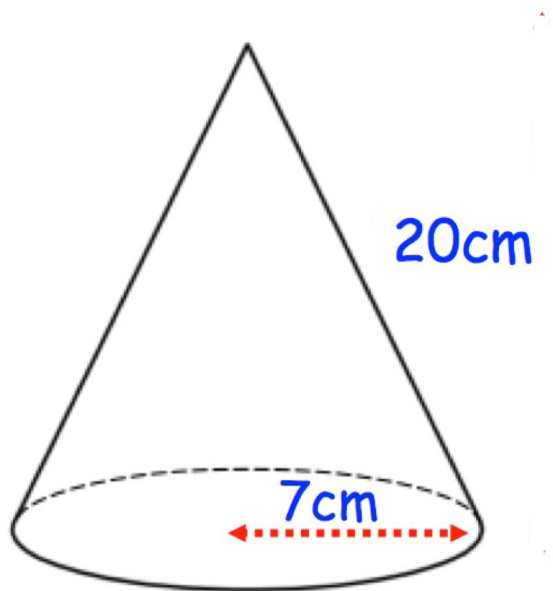

Sphere

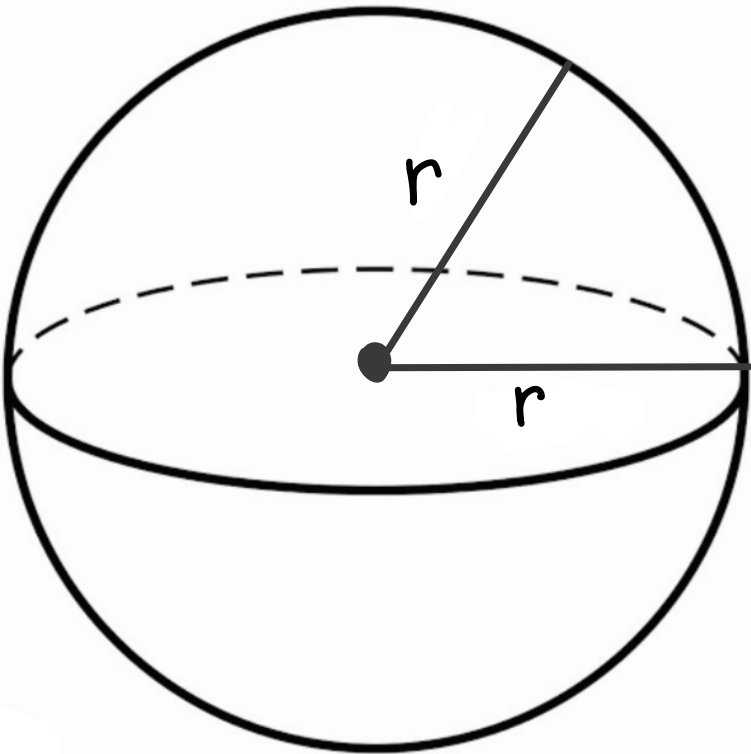

Example

Find the total surface area

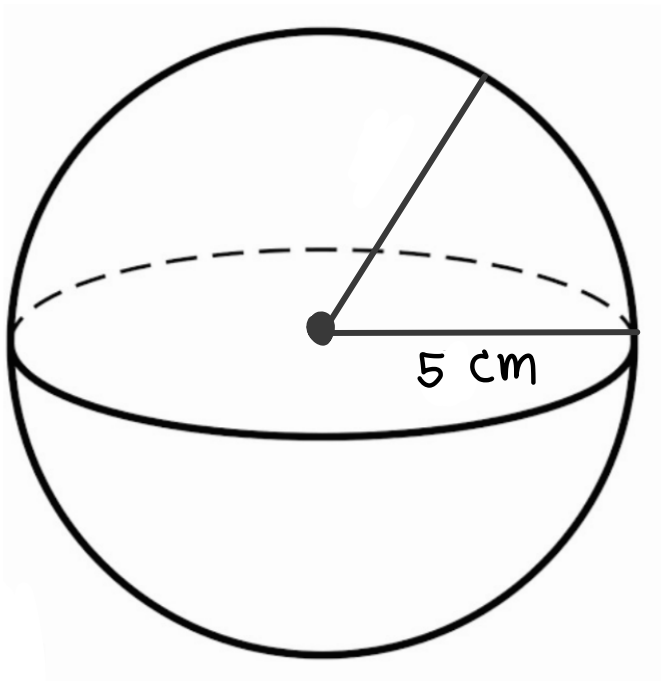

Hemisphere

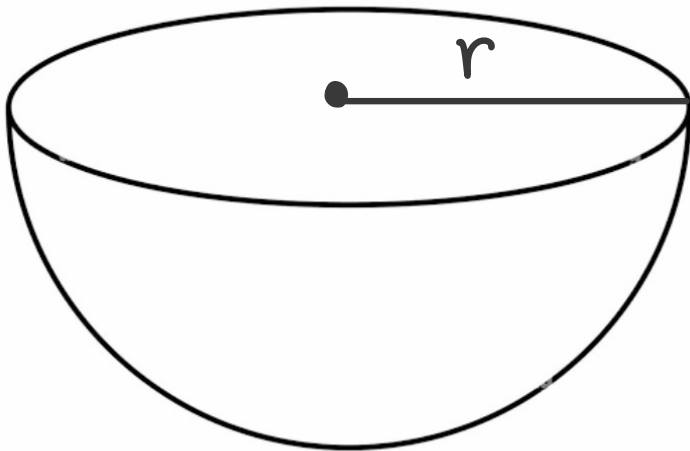

Example

Find the total surface area

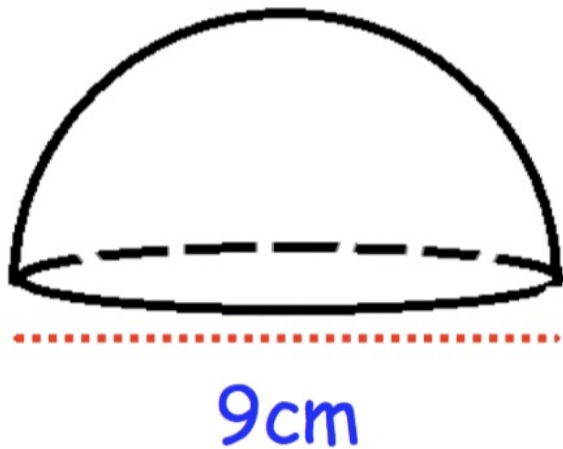

Note :

Frustum

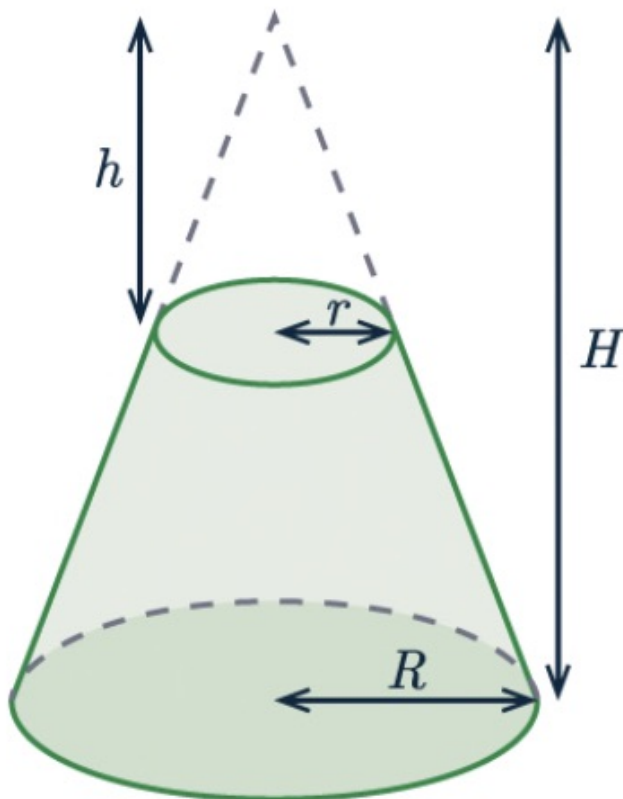

The frustum of a cone is the 3D shapes that is left over after you cut the top off

Example

Find the volume of frustum

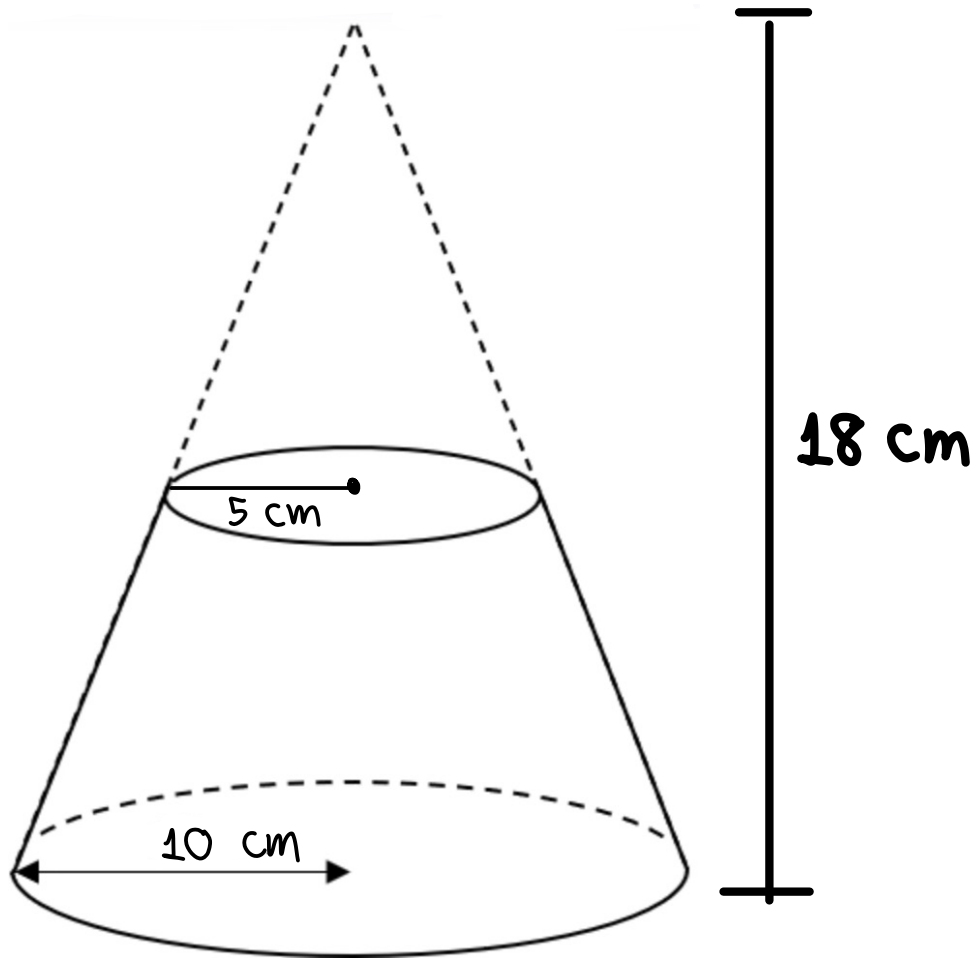

1. The diagram shows a shape.

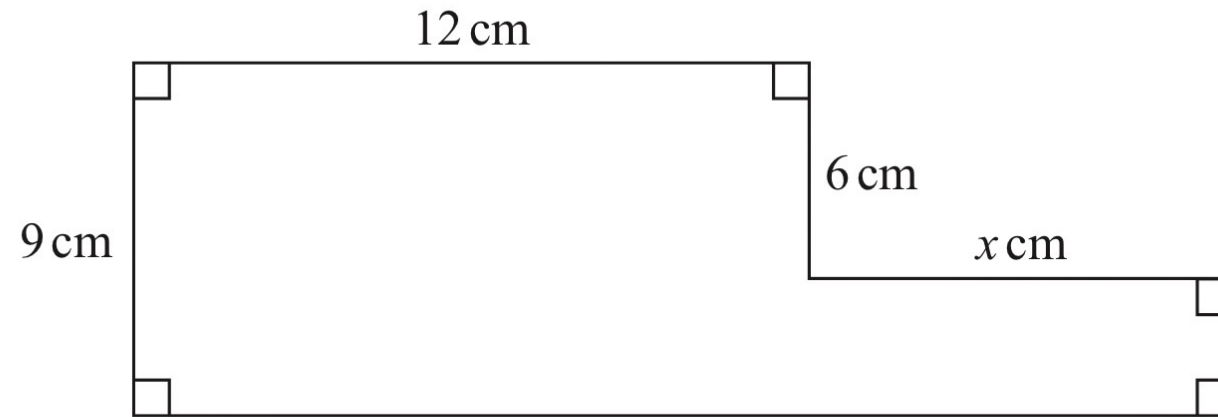

The shape has area 129 cm^2

Work out the value of x .

2.

The diagram shows a solid cylinder with radius 3 m.

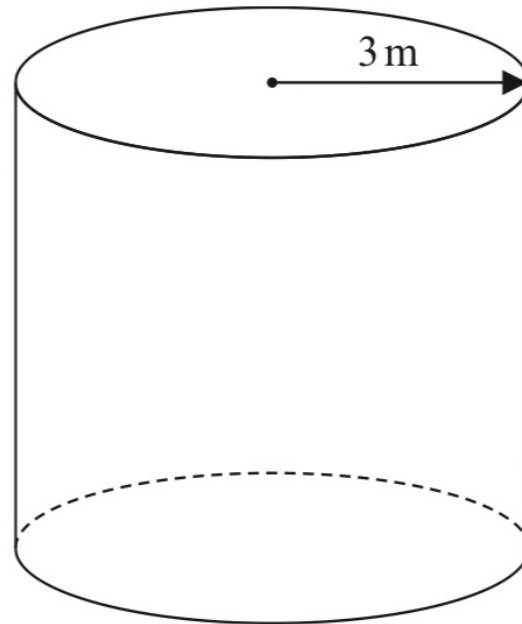

The volume of the cylinder is $72\pi \text{ m}^3$

Calculate the **total** surface area of the cylinder.
Give your answer correct to 3 significant figures.

3. A solid is made from a hemisphere and a cylinder.
The plane face of the hemisphere coincides with the upper plane face of the cylinder.

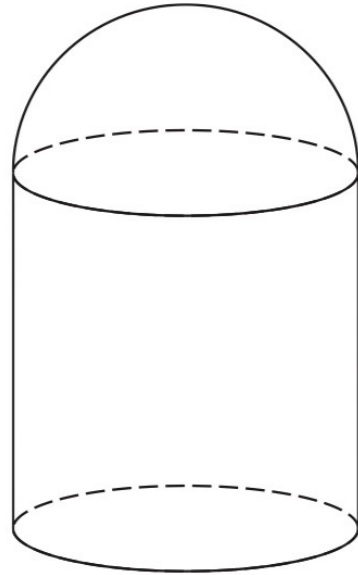

The hemisphere and the cylinder have the same radius.

The ratio of the radius of the cylinder to the height of the cylinder is 1 : 3

Given that the solid has volume $792\pi \text{ cm}^3$
work out the height of the solid.

4. Here are a solid sphere and a solid cylinder.

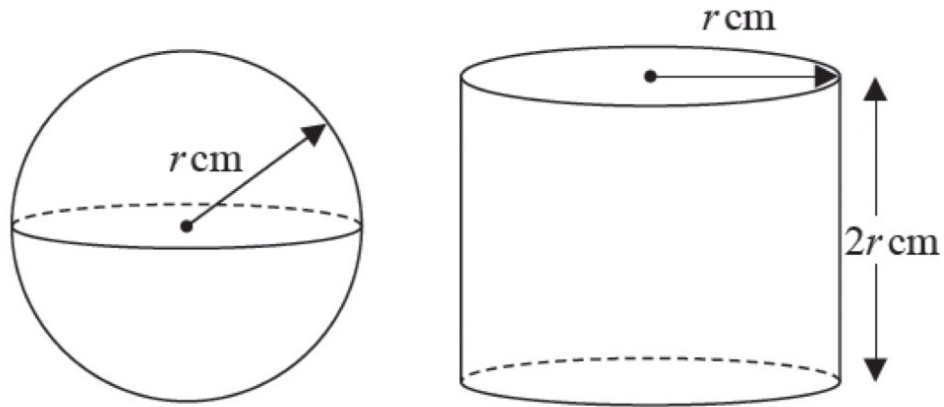

The radius of the sphere is r cm.

The radius of the cylinder is r cm.

The height of the cylinder is $2r$ cm.

The total surface area of the cylinder is $k\pi$ cm²

Find an expression for k in terms of r .

5. Here is a sector, AOB , of a circle with centre O and angle $AOB = x^\circ$

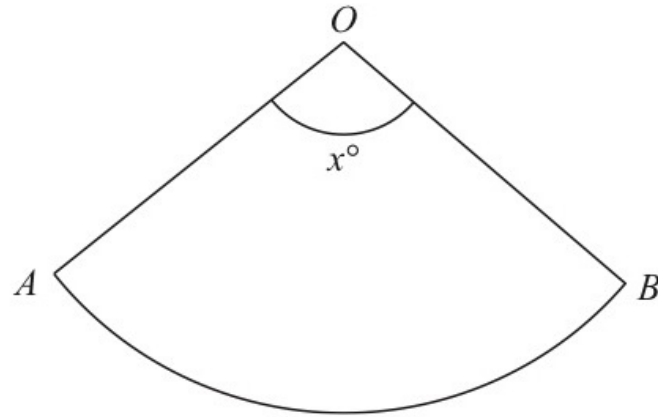

The sector can form the curved surface of a cone by joining OA to OB .

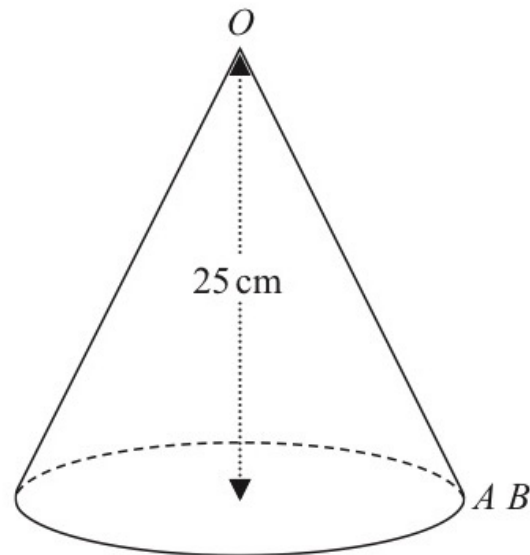

The height of the cone is 25 cm .

The volume of the cone is 1600 cm^3

Work out the value of x .

Give your answer correct to the nearest whole number.

6.

The diagram shows a frustum of a cone and a sphere.

The frustum is made by removing a small cone from a large cone.

The cones are similar.

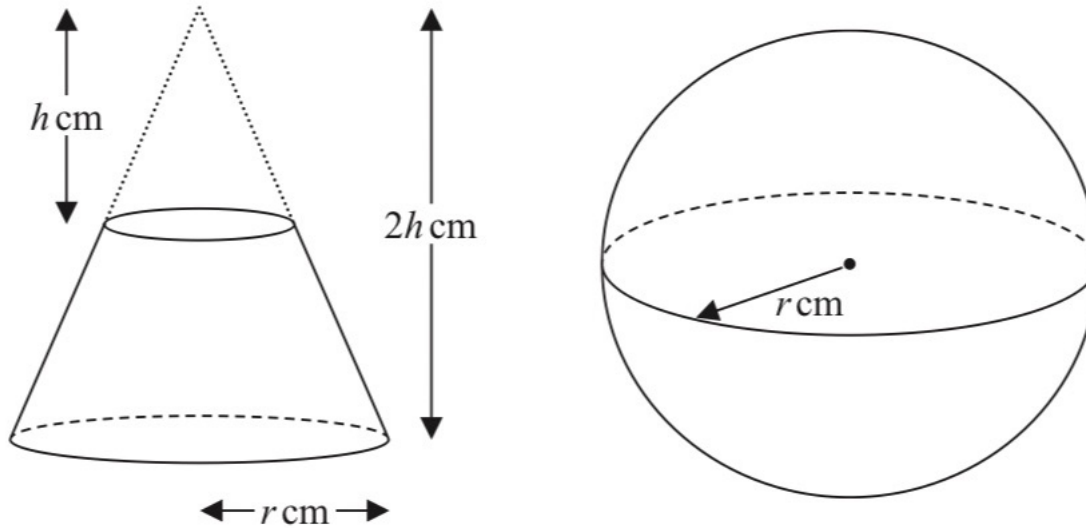

The height of the small cone is h cm.

The height of the large cone is $2h$ cm.

The radius of the base of the large cone is r cm.

The radius of the sphere is r cm.

Given that the volume of the frustum is equal to the volume of the sphere,

find an expression for r in terms of h .

Give your expression in its simplest form.

7. The diagram shows a prism $ABCDEFGH$ in which $ABCD$ is a trapezium with BC parallel to AD and $CDEF$ is a rectangle.

$$BC = 7 \text{ cm} \quad AD = 12 \text{ cm} \quad DE = 10 \text{ cm}$$

The height of trapezium $ABCD$ is h cm

The volume of the prism is 608 cm^3

Work out the value of h .

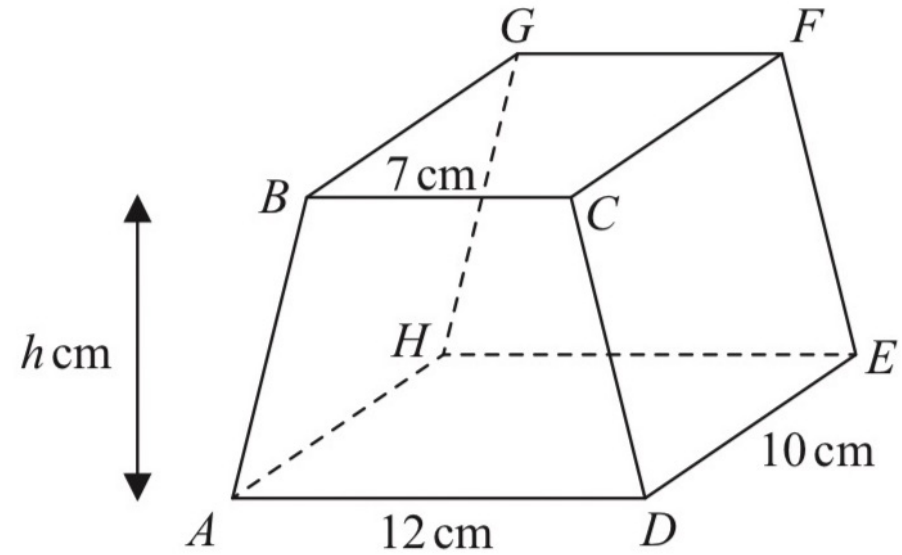

8. The diagram shows a sphere of diameter x cm and a pyramid $ABCDE$ with a horizontal rectangular base $BCDE$.

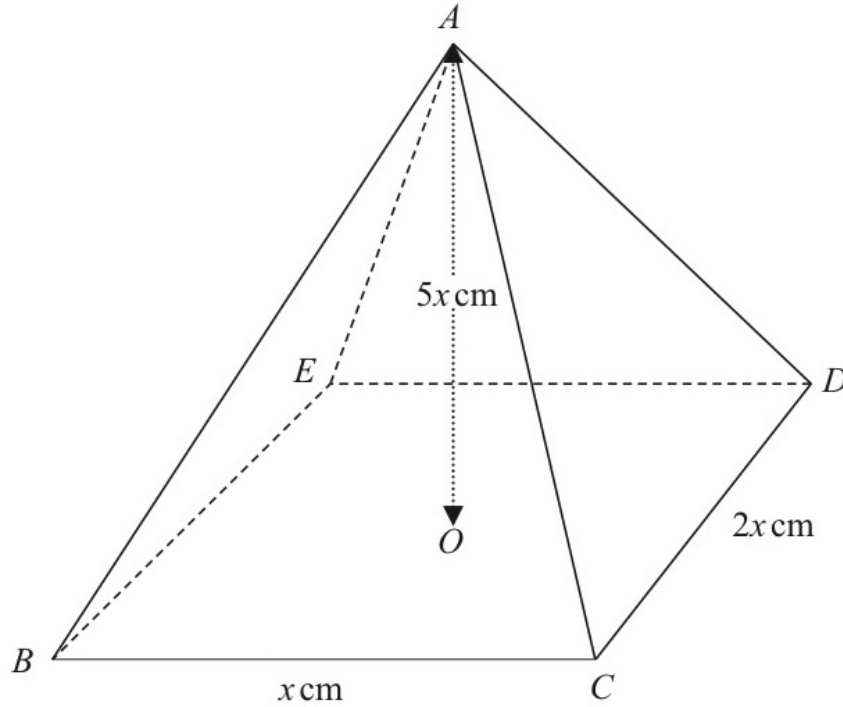
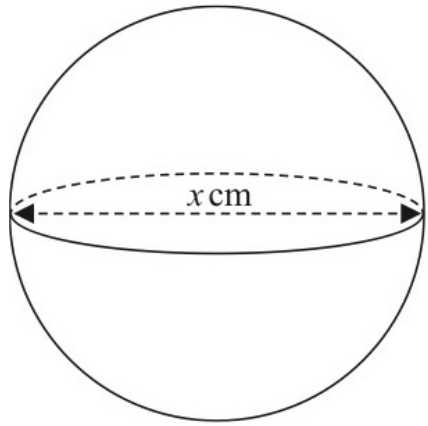

The vertex A of the pyramid is vertically above the centre O of the base so that $AB = AC = AD = AE$.

$BC = x$ cm, $CD = 2x$ cm and $AO = 5x$ cm.

The volume of the sphere is 288π cm³

Calculate the total surface area of the pyramid.

Give your answer correct to the nearest cm²

9.
The diagram shows a solid prism $ABCDEFGH$.

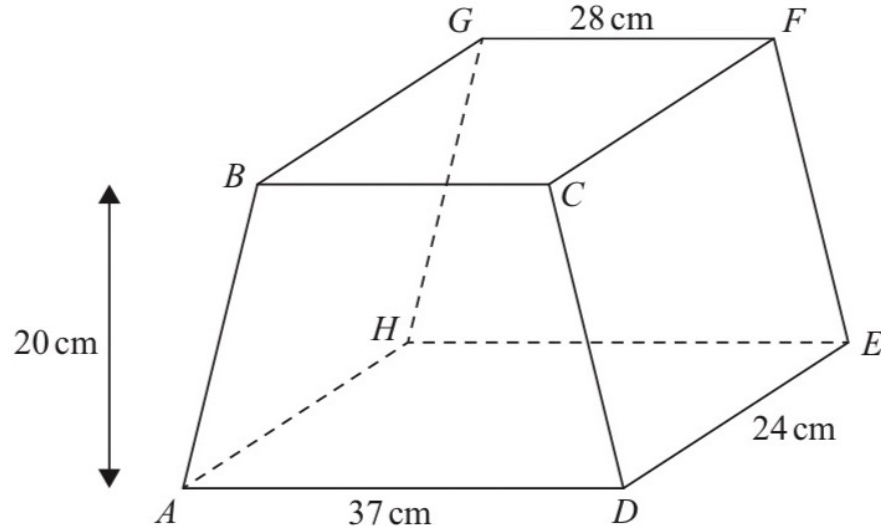

The trapezium $ABCD$, in which AD is parallel to BC , is a cross section of the prism.
The base $ADEH$ of the prism is a horizontal plane.
 $ADEH$ and $BCFG$ are rectangles.
The midpoint of BC is vertically above the midpoint of AD so that $BA = CD$.

$$AD = 37 \text{ cm} \qquad GF = 28 \text{ cm} \qquad DE = 24 \text{ cm}$$

The perpendicular distance between edges AD and BC is 20 cm.

Work out the total surface area of the prism.

10. The diagram shows the cross section of a circular water pipe.

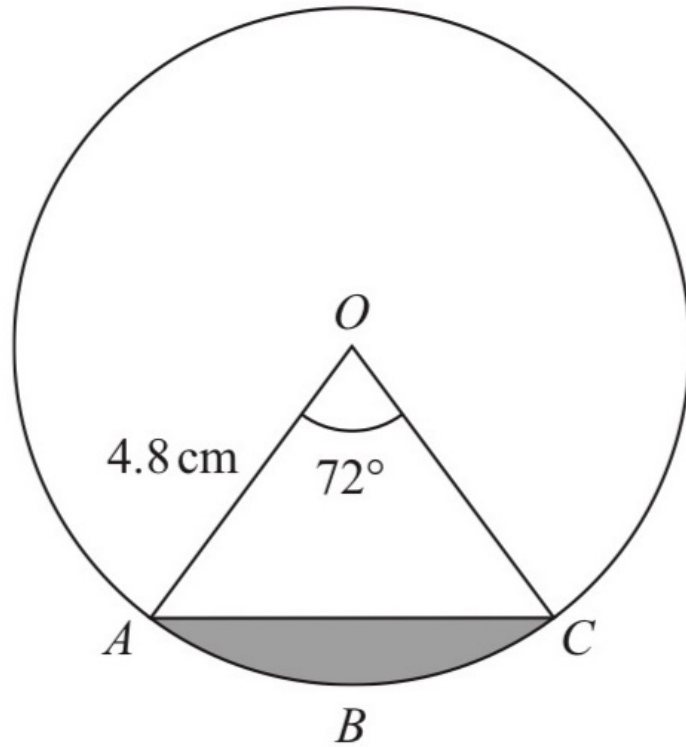

OAC is a sector of the circle, centre O

The shaded region in the diagram represents the water flowing in the pipe.

The water flows at 14 cm/s in the pipe.

Work out the volume of water that has flowed through the pipe in 3 minutes.
Give your answer in cm^3 correct to 3 significant figures.

Pythagoras Theorem and Trigonometry

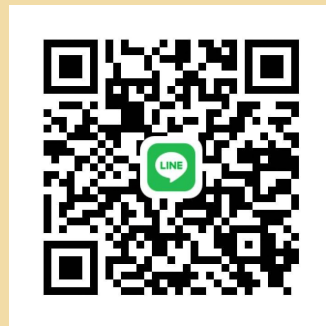

By Kru ชี

Pythagoras Theorem

The ratio between sides in right angle triangles

Calculate missing length by using
SIN , COS , TAN

Example

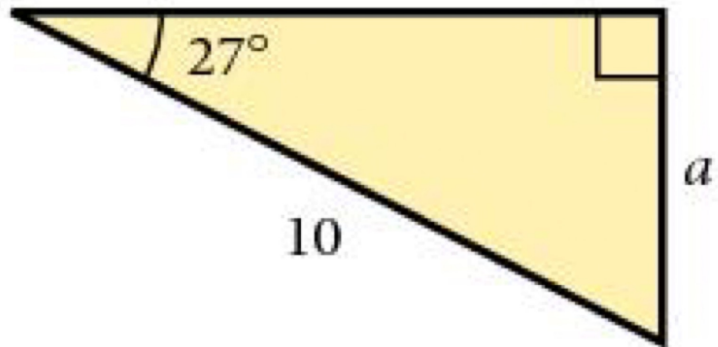

Calculate missing angle by using
 SIN^{-1} , COS^{-1} , TAN^{-1}

Example

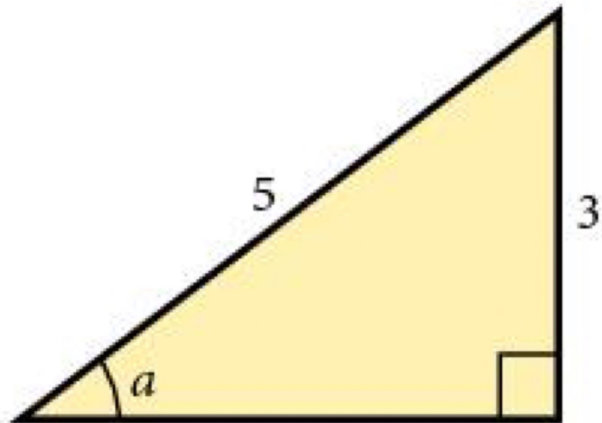

3-D shapes

Cube

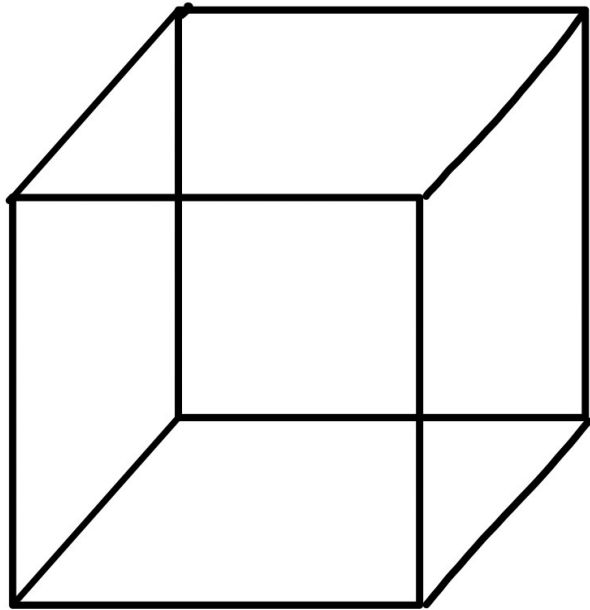

Cuboid

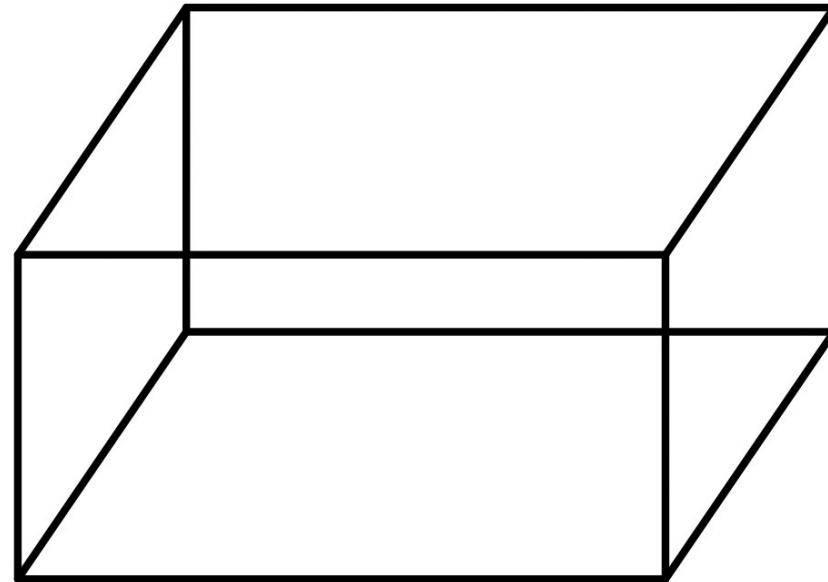

Prism

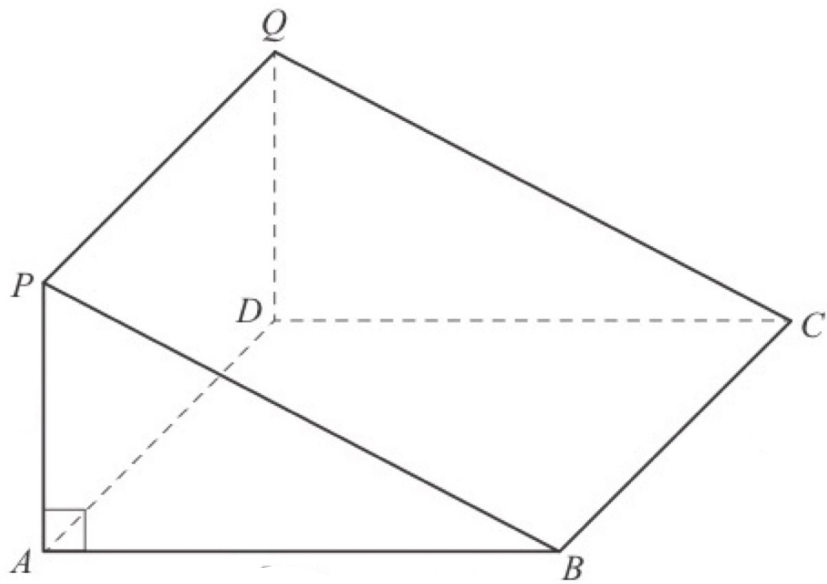

Pyramid

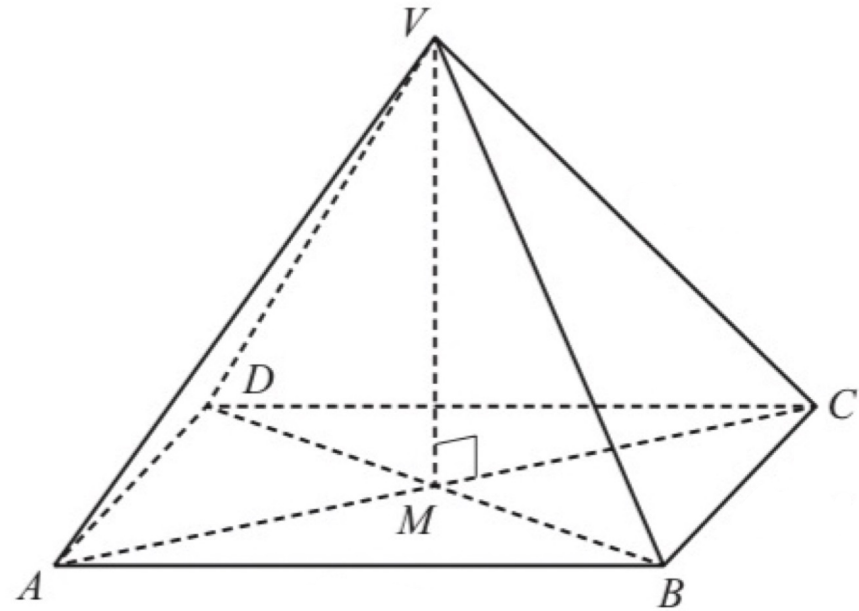

Rules

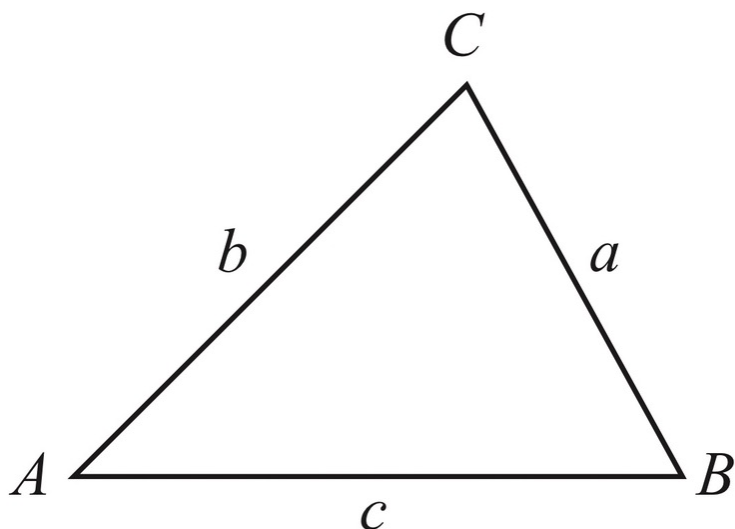

In any triangle ABC

Sine Rule $\frac{a}{\sin A} = \frac{b}{\sin B} = \frac{c}{\sin C}$

Cosine Rule $a^2 = b^2 + c^2 - 2bc \cos A$

Area of triangle $= \frac{1}{2} ab \sin C$



Area of triangles



Example

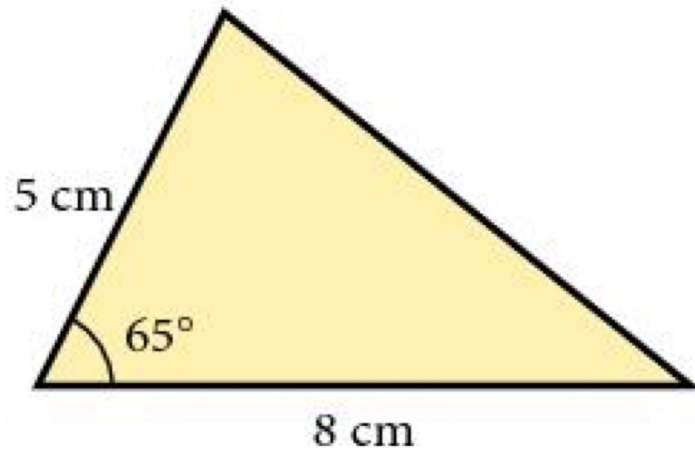



Example

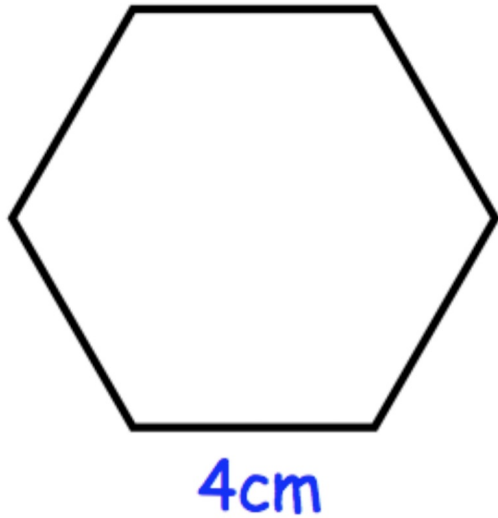

A regular hexagon has side length 4cm.

Calculate the area of the hexagon.



Sine Rule



Example

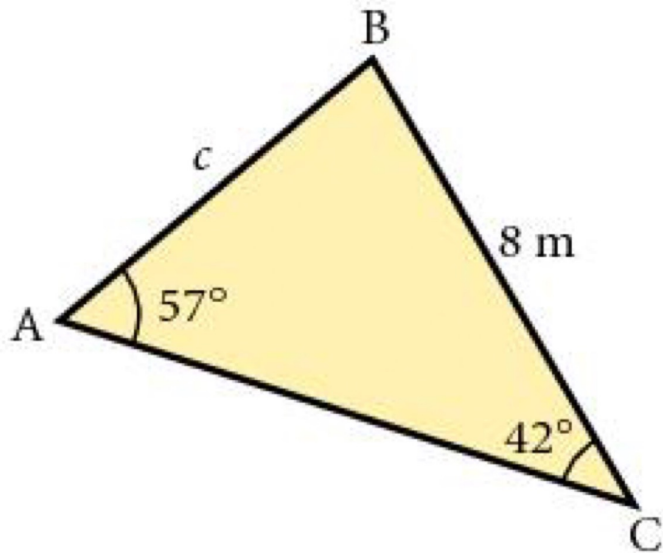



Example

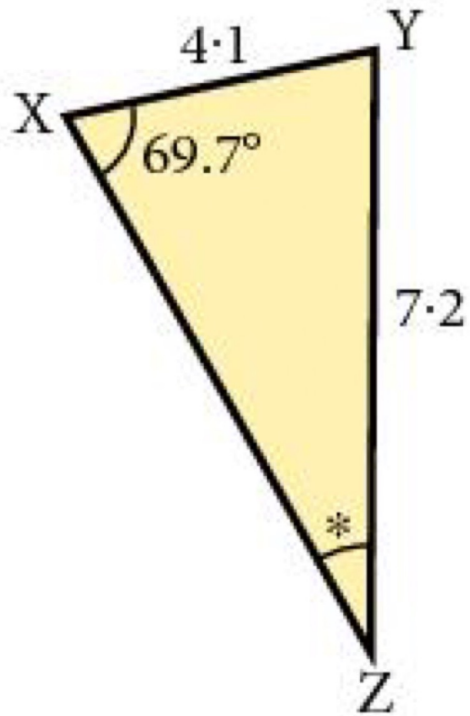



Example

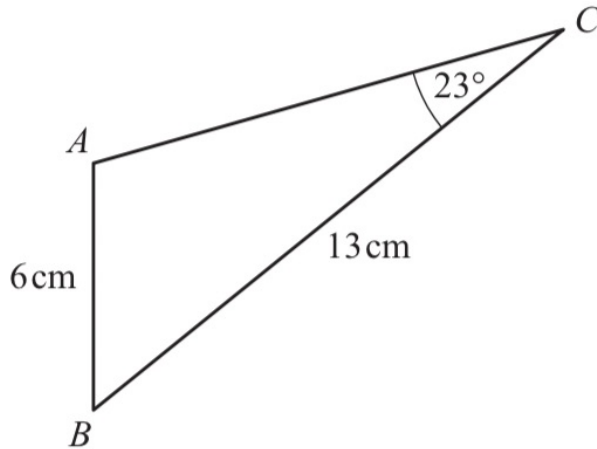

In triangle ABC , $AB = 6$ cm, $BC = 13$ cm and angle $ACB = 23^\circ$.
Calculate angle BAC , which is obtuse.



Cosine Rule



Example

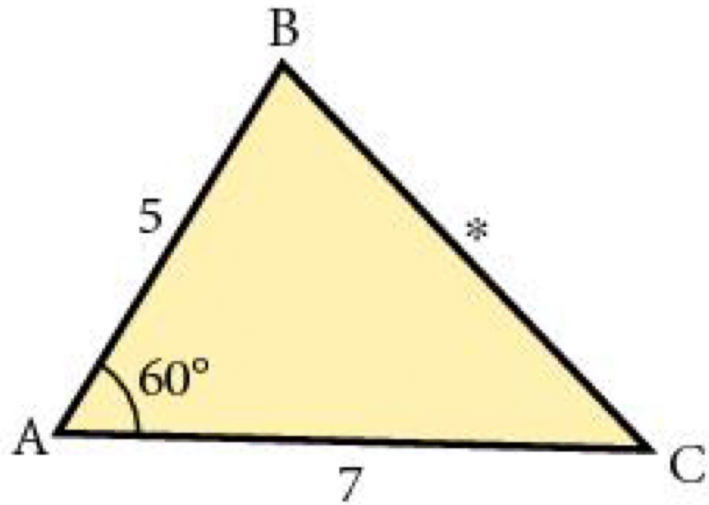



Example

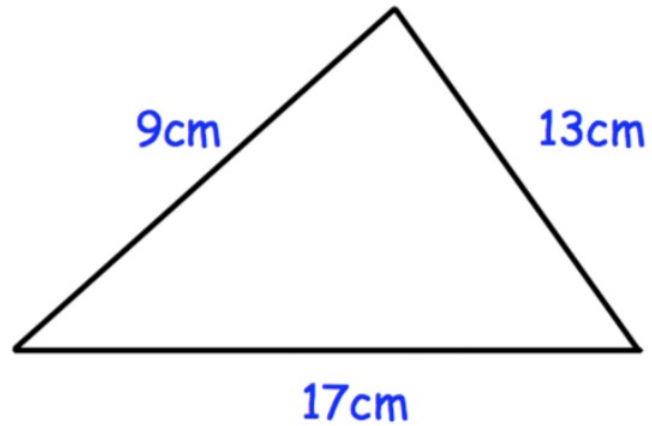

Calculate the smallest angle in the triangle.

Bearing

Find the bearing of A from B

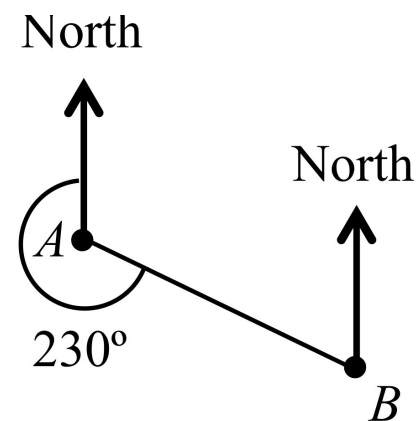
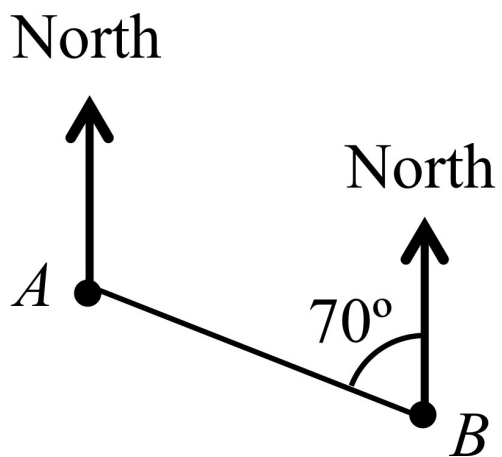

Angles of elevation

Angles of depression

1. The diagram shows a rectangle and a diagonal of the rectangle.

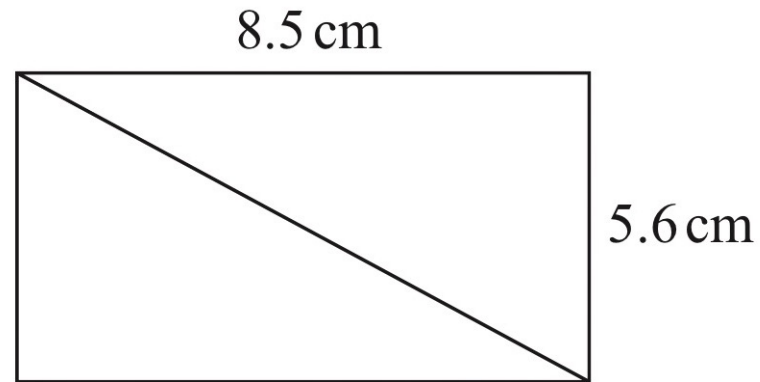

Work out the length of the diagonal of the rectangle.
Give your answer correct to 1 decimal place.

2. The diagram shows a right-angled triangle.

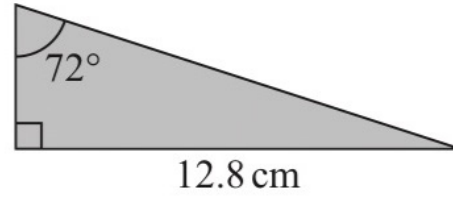

Five of these triangles are put together to make a shape.

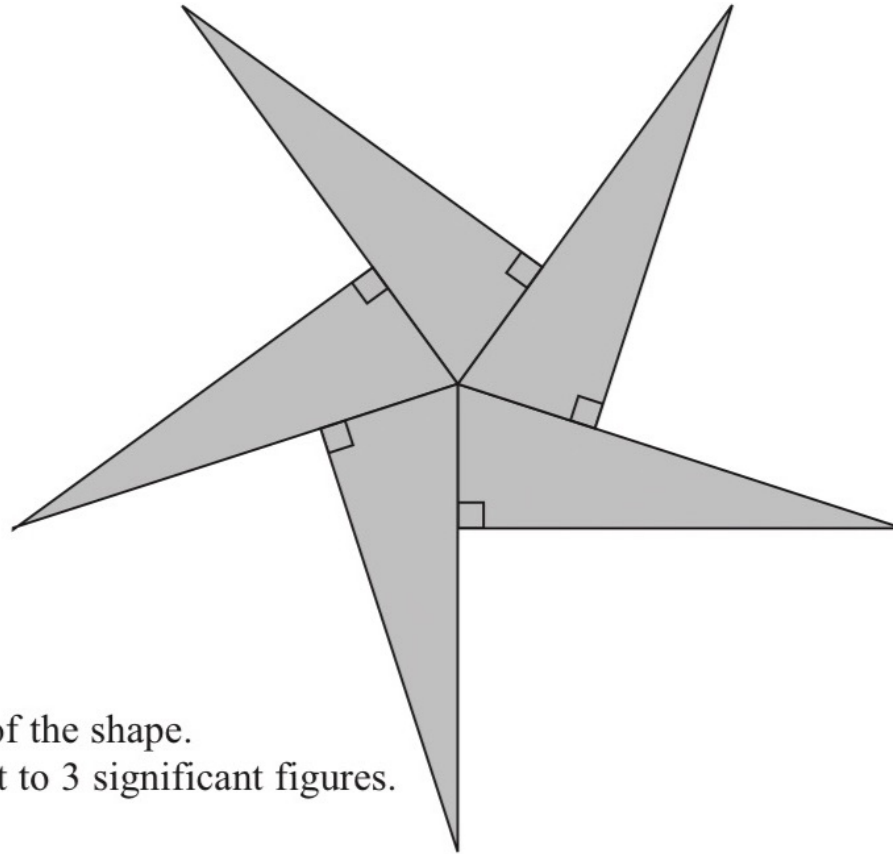

Calculate the perimeter of the shape.
Give your answer correct to 3 significant figures.

3. The diagram shows two hot air balloons.
 A is a point on the base of one of the balloons and B is a point on the base of the other balloon.

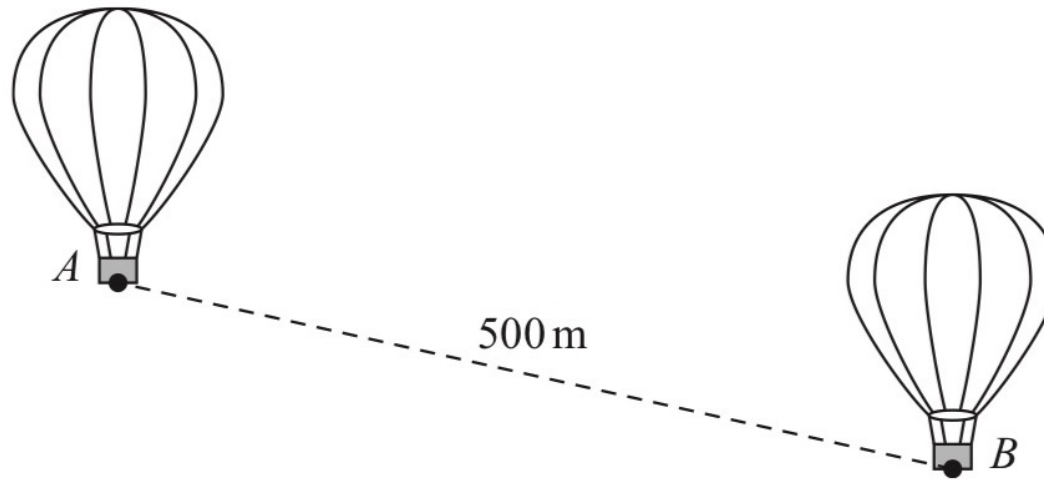
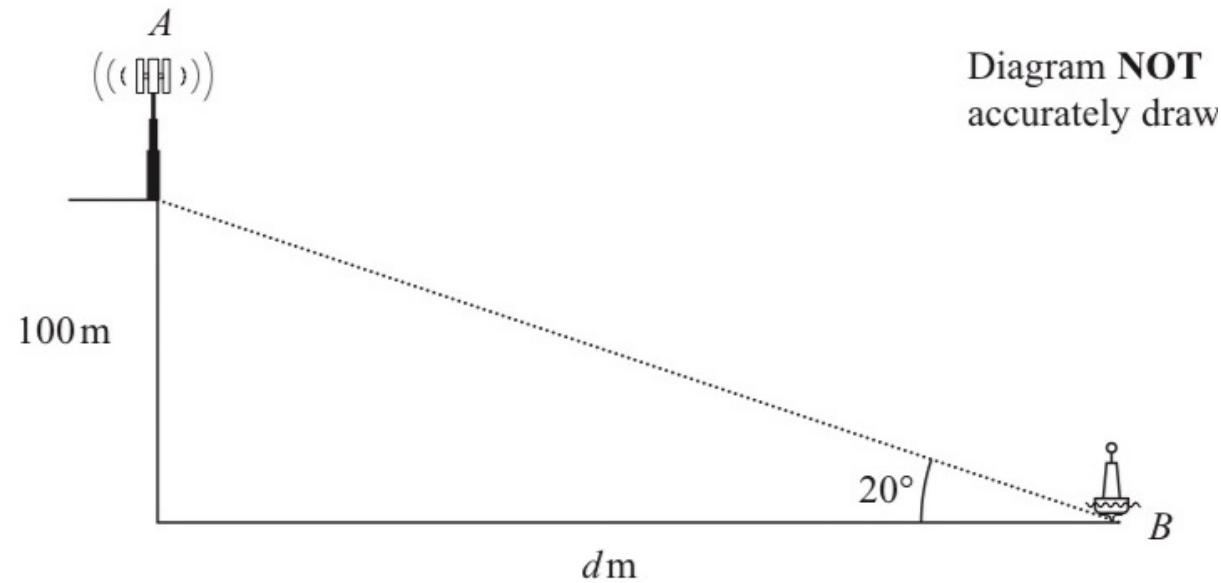

Diagram **NOT**
accurately drawn

The distance between A and B is 500 metres.
The angle of depression of B from A is 23°

Calculate the vertical height of A above B .
Give your answer correct to one decimal place.

4. The diagram shows a vertical cliff with a vertical radio mast on top of the cliff and a buoy in the sea.



The height of the cliff is 100 metres.

The buoy is at the point B that is d metres from the base of the cliff.

The angle of elevation from B to the top of the cliff is 20°

- (a) Calculate the value of d .

Give your answer correct to 3 significant figures.

The point A at the top of the radio mast is vertically above the top of the cliff.

The angle of elevation from B to A is 25°

- (b) Calculate the height of the radio mast.

Give your answer correct to 3 significant figures.

5. The diagram shows trapezium $ABCD$ in which BC and AD are parallel.

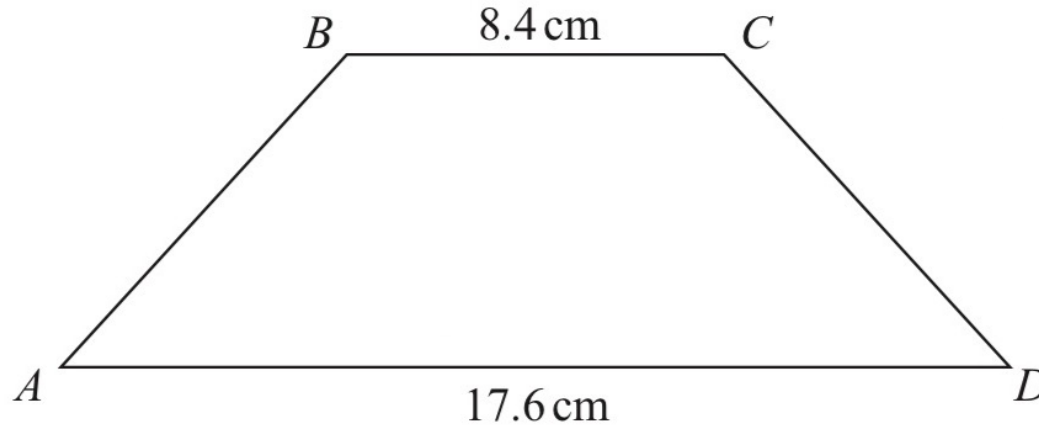

The trapezium has exactly one line of symmetry.

$$BC = 8.4\text{ cm}$$

$$AD = 17.6\text{ cm}$$

The trapezium has area 179.4 cm^2

Work out the size of angle ABC .

Give your answer correct to 1 decimal place.

6. The diagram shows two right-angled triangles, DEF and EFG .

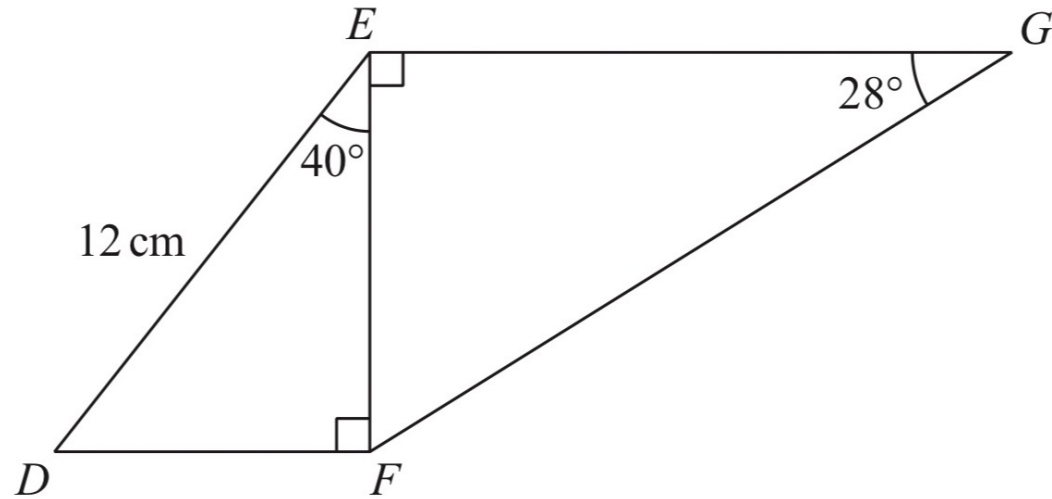

Work out the length of EG .

Give your answer correct to 3 significant figures.

7. Here is a quadrilateral $PQRS$.

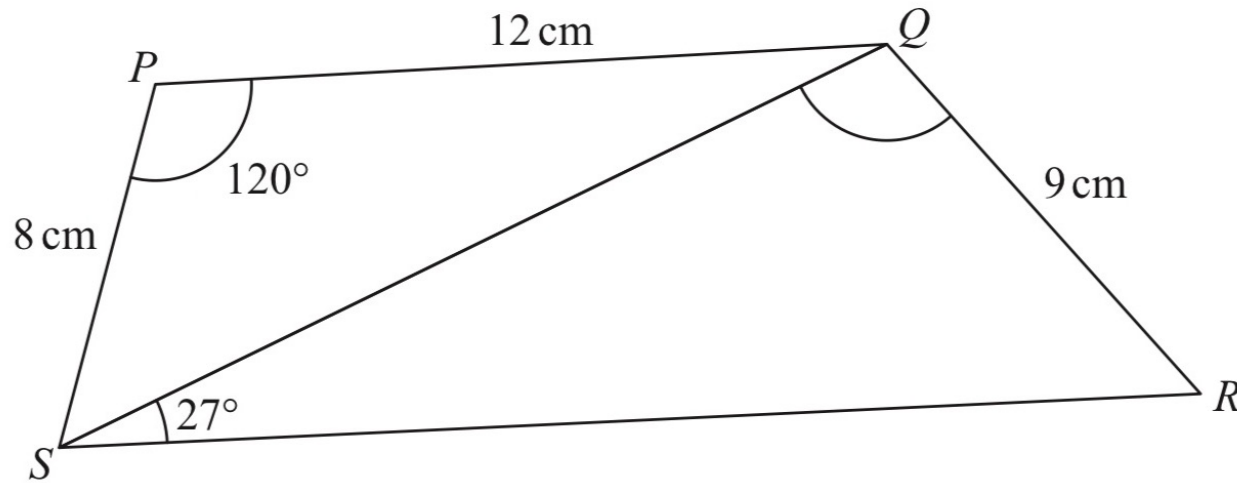

Angle SRQ is acute.

Work out the size of angle SQR .

Give your answer correct to 1 decimal place.

8. Here is a quadrilateral $ABCD$.

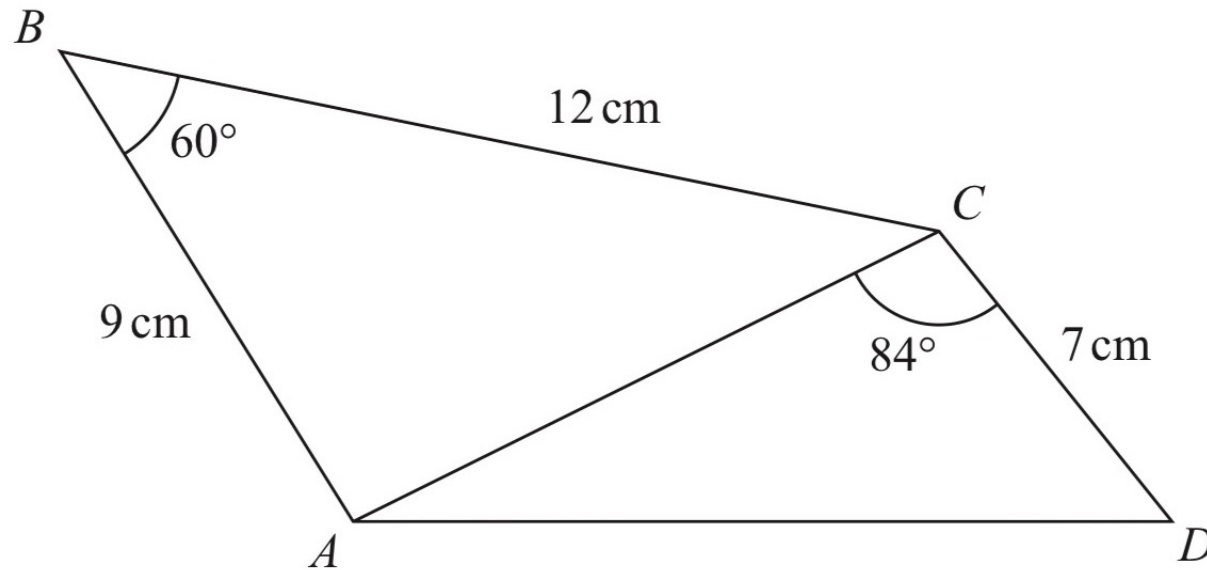

Calculate the area of quadrilateral $ABCD$.
Give your answer correct to 3 significant figures.
Show your working clearly.

9. The diagram shows the positions of three ships, A , B and C .

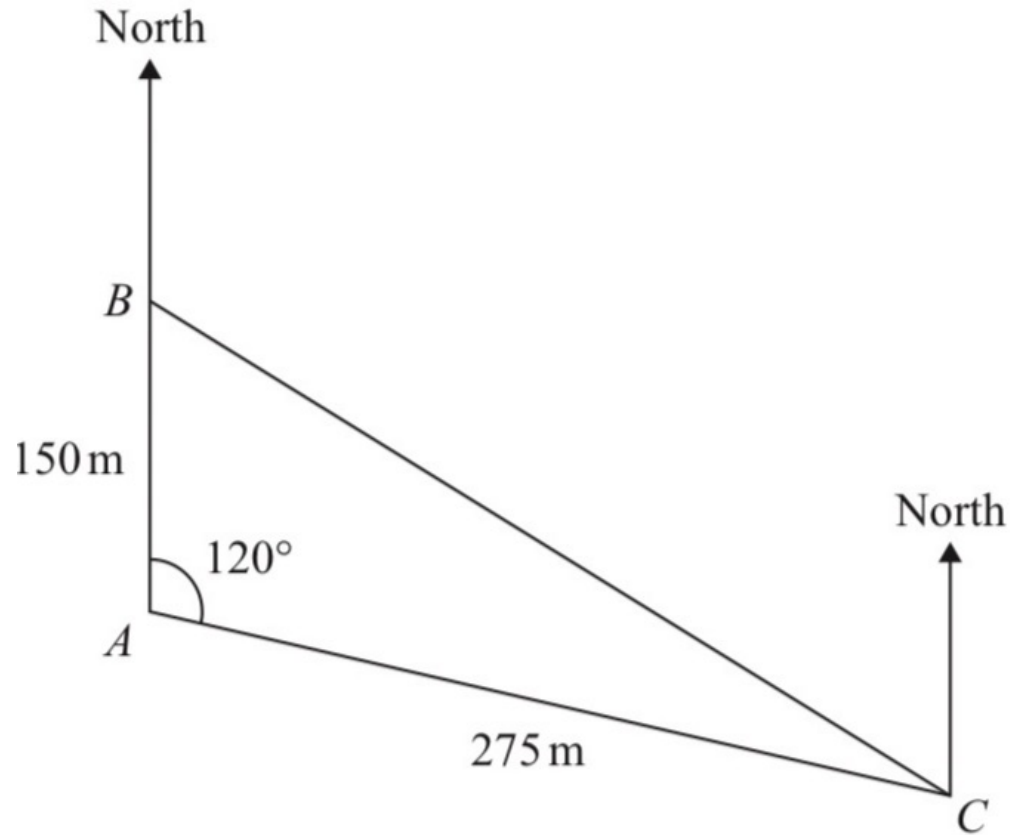

Ship B is due north of ship A .

The bearing of ship C from ship A is 120°

Calculate the bearing of ship C from ship B .

Give your answer correct to the nearest degree.

10. AEC and BED are chords of a circle.

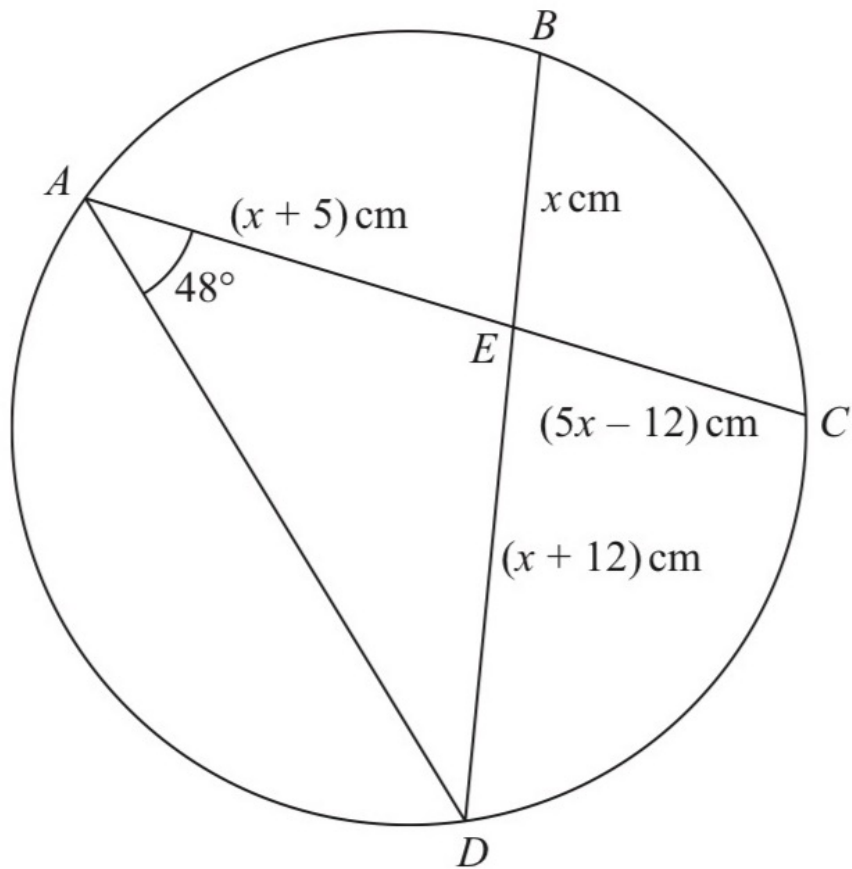

$$AE = (x + 5) \text{ cm} \quad BE = x \text{ cm} \quad CE = (5x - 12) \text{ cm} \quad DE = (x + 12) \text{ cm}$$

$$\text{Angle } DAE = 48^\circ$$

Work out the size of angle ADE

Give your answer correct to one decimal place.

11. Here is a triangle XYZ .

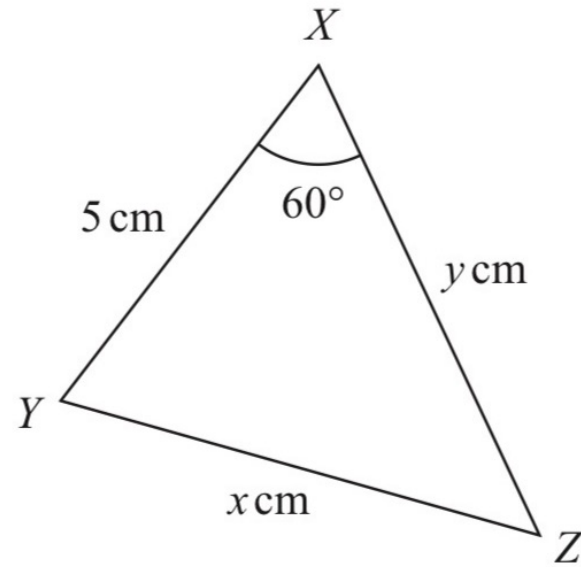

The perimeter of the triangle is $k\text{ cm}$.

Given that $x = y - 1$

find the value of k .

Show your working clearly.

12.

The diagram shows a triangular prism.

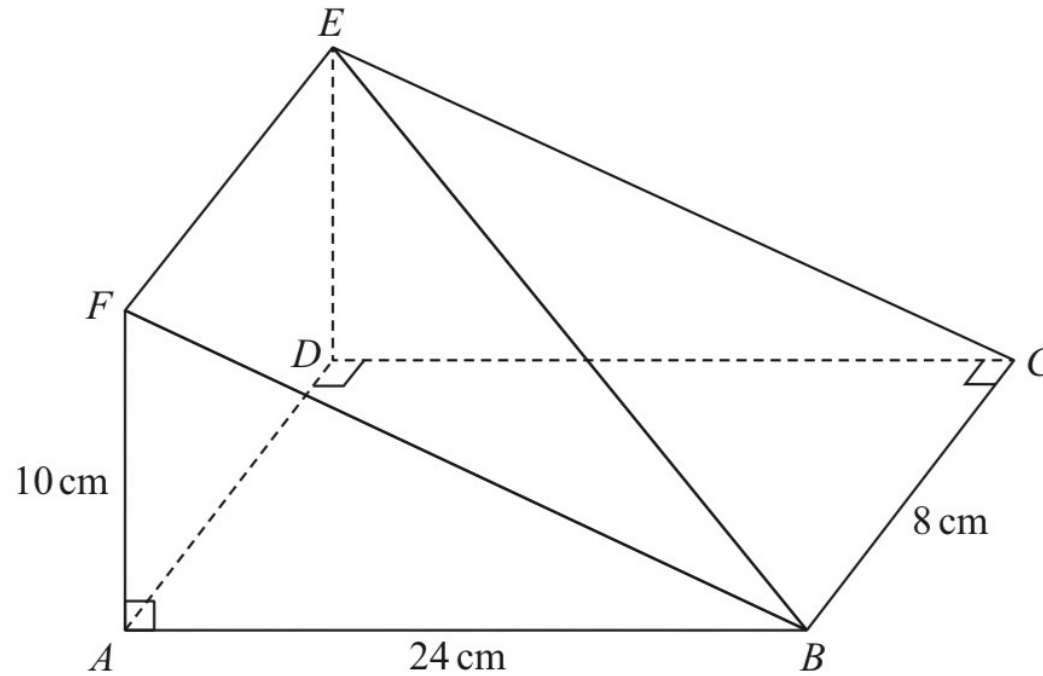

$AF = 10\text{ cm}$, $AB = 24\text{ cm}$ and $BC = 8\text{ cm}$.

Angle $FAB = \text{angle } ADC = \text{angle } BCD = 90^\circ$

Work out the size of the angle between the line BE and the plane $ABCD$.

Give your answer correct to 1 decimal place.

13. The diagram shows a triangular prism, $ABCDEF$, with a rectangular base $ABCD$

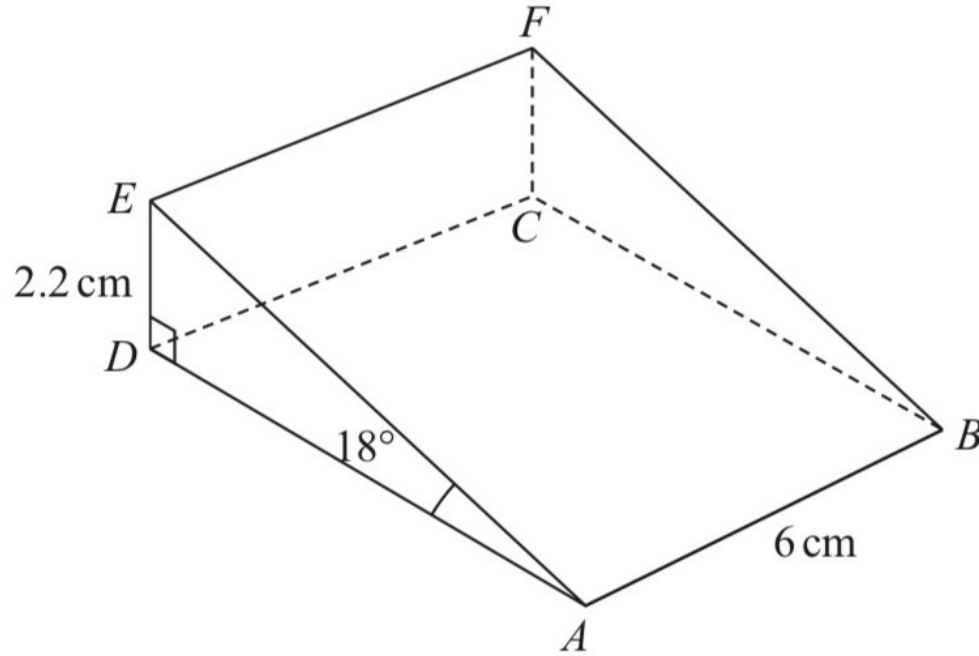

$$AB = 6 \text{ cm}$$

$$DE = 2.2 \text{ cm}$$

$$\text{angle } DAE = 18^\circ$$

$$\text{angle } ADE = 90^\circ$$

Work out the angle that BE makes with the plane $ABCD$

Give your answer correct to one decimal place.

14. The diagram shows cuboid $ABCDEFGH$.

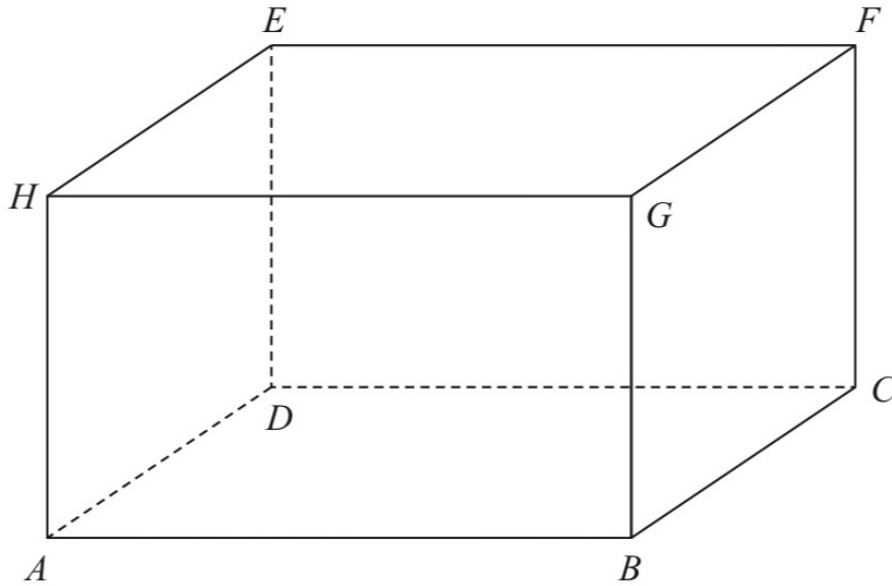

For this cuboid

the length of AB : the length of BC : the length of $CF = 4 : 2 : 3$

Calculate the size of the angle between AF and the plane $ABCD$.
Give your answer correct to one decimal place.

15. The diagram shows a solid pyramid $ABCDE$ with a horizontal base.

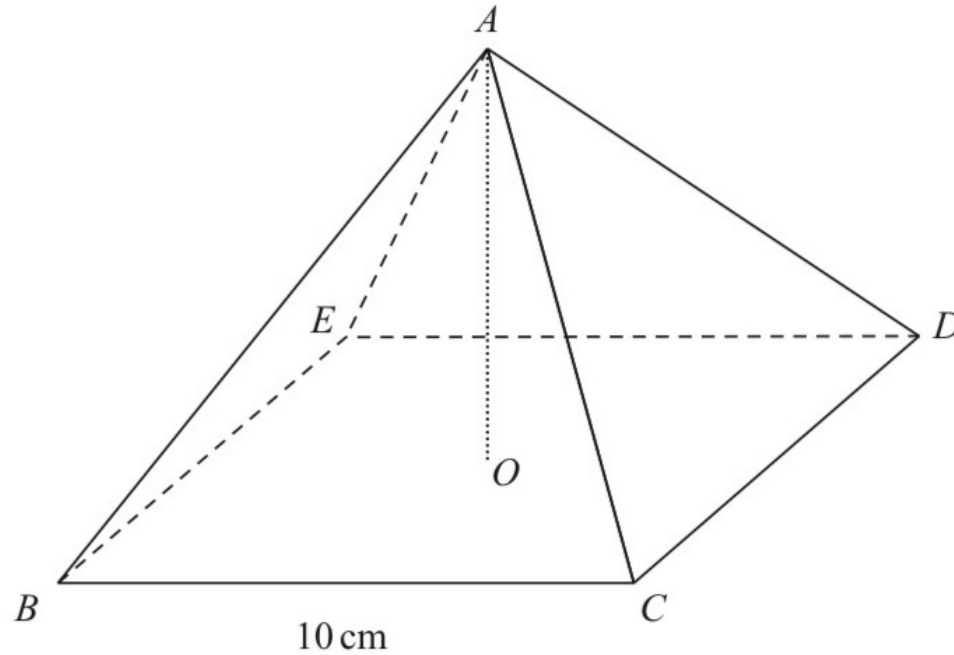

The base, $BCDE$, of the pyramid is a square of side 10 cm .

The vertex A of the pyramid is vertically above the centre O of the base so that $AB = AC = AD = AE$

The **total** surface area of the pyramid is 360 cm^2

Work out the size of the angle between AC and the base $BCDE$.
Give your answer correct to 3 significant figures.

16.

The diagram shows the prism $ABCDEF$ with cross section triangle ABC .

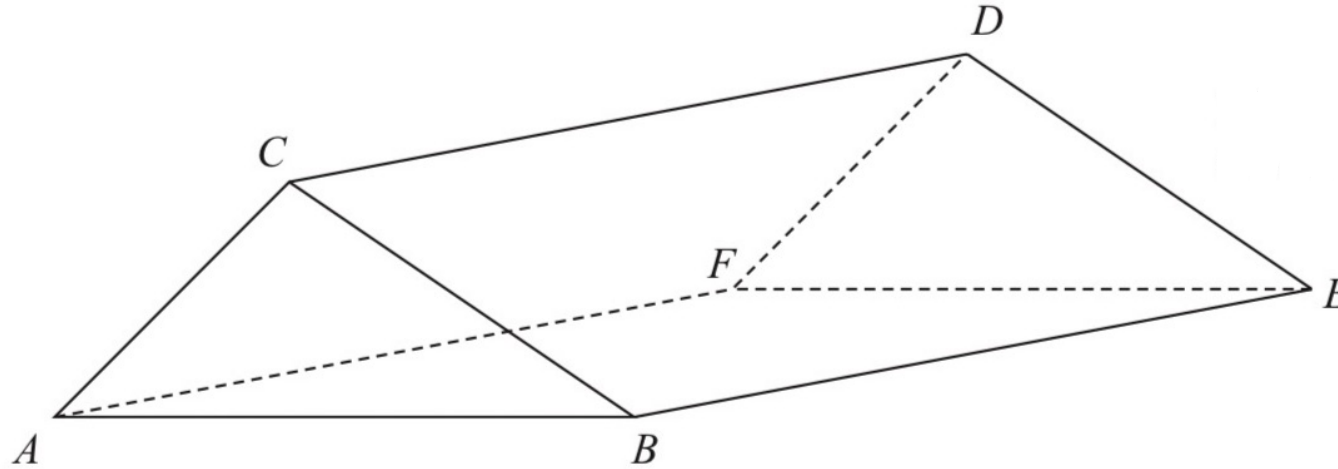

Angle $BEC = 40^\circ$ and angle ACB is obtuse.

$AC = 6$ cm and $CE = 13$ cm

The area of triangle ABC is 22 cm²

Calculate the length of AB .

Give your answer correct to one decimal place.

17. The diagram shows cuboid $ABCDEFGH$.

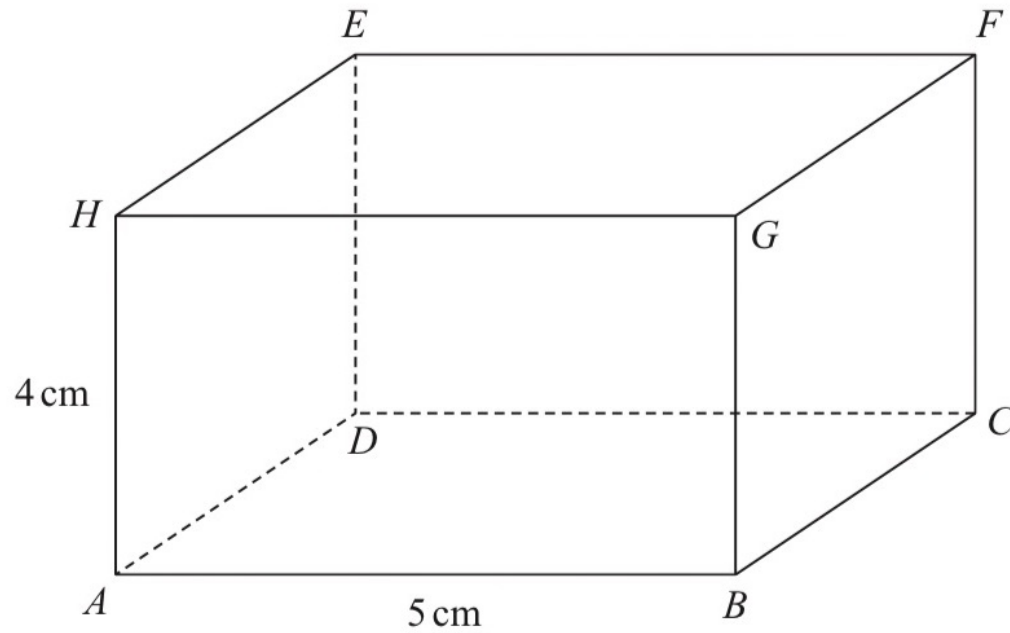

$$AB = 5\text{ cm}$$

$$AH = 4\text{ cm}$$

The size of the angle between CH and the plane $ABCD$ is 35°

Calculate the volume of the cuboid.

Give your answer correct to 3 significant figures.

18. ABC is an isosceles triangle in a horizontal plane.
The point T is vertically above B .

Angle $ABC = 140^\circ$
 $AB = BC = 8 \text{ cm}$
 $TB = 10 \text{ cm}$
 M is the midpoint of AC .

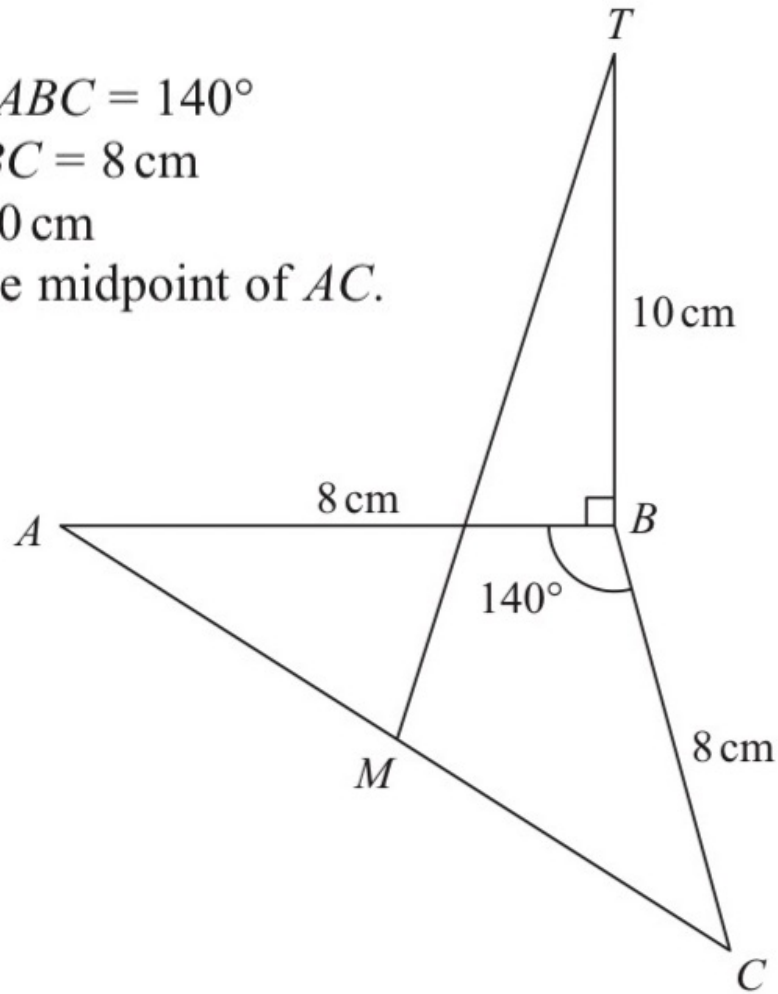

Calculate the size of the angle between MT and the horizontal plane ABC .
Give your answer correct to one decimal place.

19. The diagram shows a regular octagon $ABCDEFGH$.

Each side of the octagon has length 10 cm.

Find the area of the shaded region $ACDEH$.
Give your answer correct to the nearest cm^2

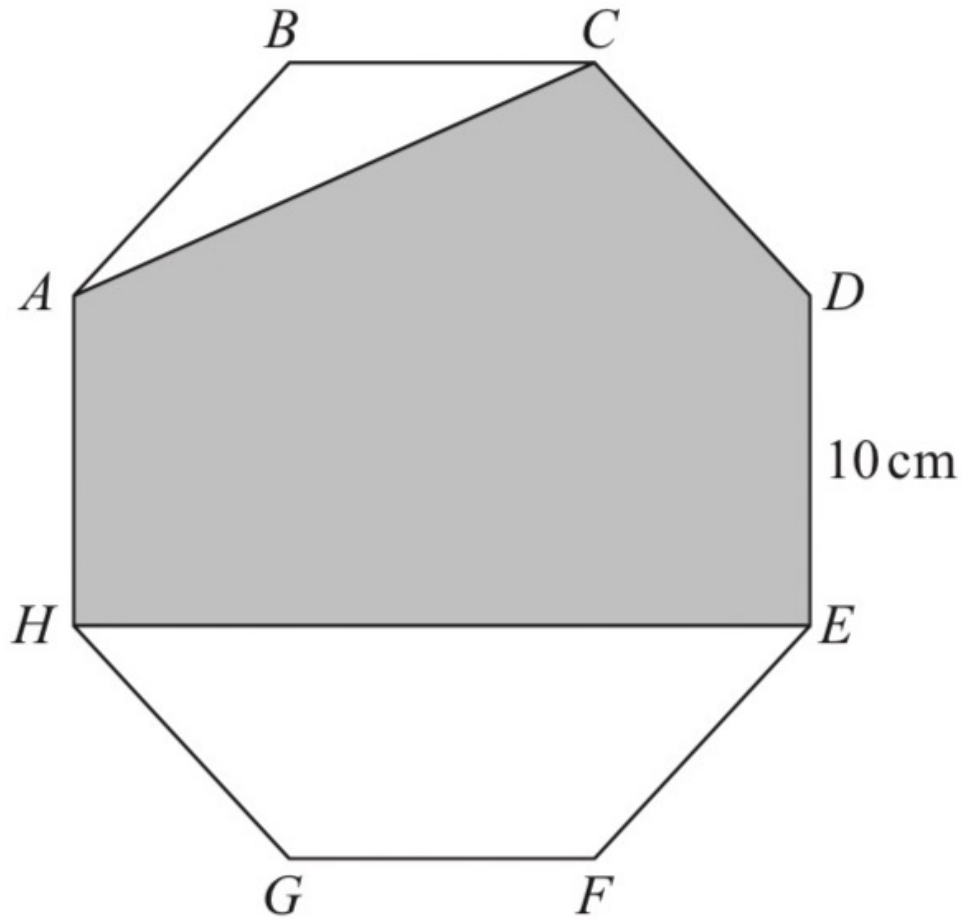

20. The diagram shows two circles such that the region **R**, shown shaded in the diagram, is the region common to both circles.

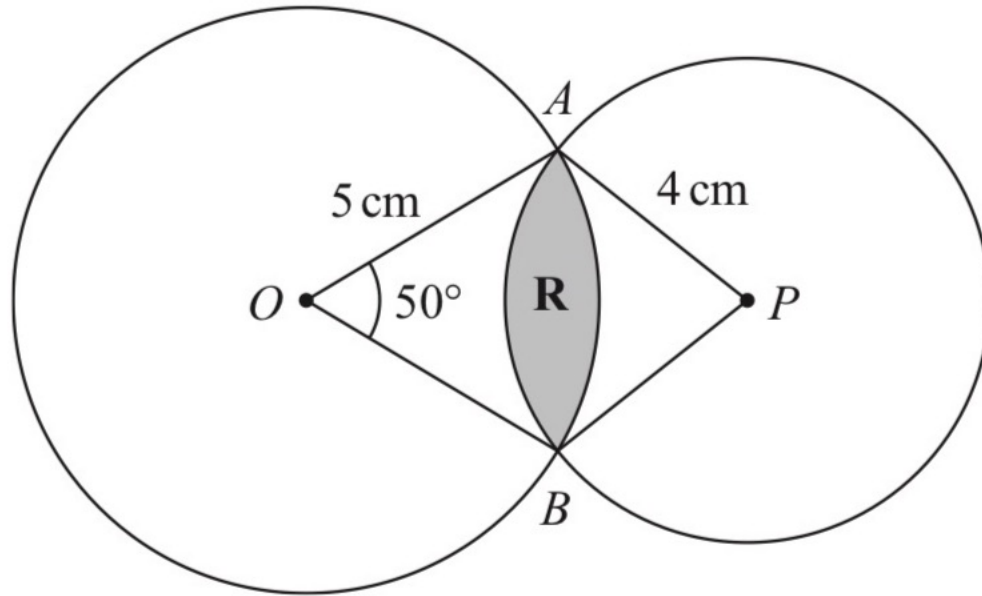

One of the circles has centre O and radius 5 cm .
The other circle has centre P and radius 4 cm .
Angle $AOB = 50^\circ$

Calculate the area of region **R**.
Give your answer correct to 3 significant figures.

21. The diagram shows a cone.

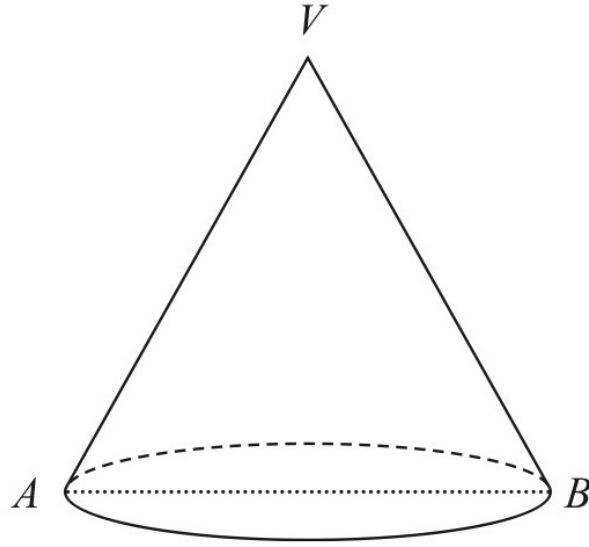

AB is a diameter of the cone.
 V is the vertex of the cone.

Given that

$$\text{the area of the base of the cone} : \text{the total surface area of the cone} = 3 : 8$$

work out the size of angle AVB .

Give your answer correct to 1 decimal place.

22. The diagram shows a solid prism $ABCDEF GHIJ$

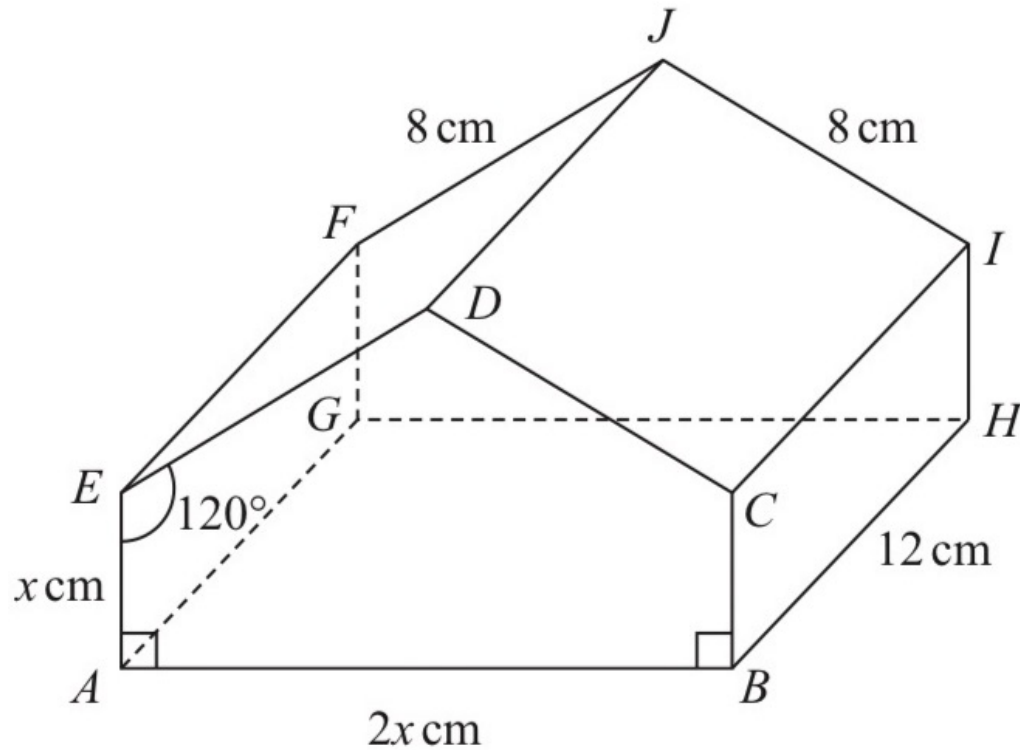

The prism is such that each cross section is a pentagon where

$$AE = BC = x \text{ cm}$$

$$AB = 2x \text{ cm}$$

$$ED = CD = 8 \text{ cm}$$

$$\text{angle } EAB = \text{angle } CBA = 90^\circ$$

$$\text{angle } AED = \text{angle } BCD = 120^\circ$$

Given that $AG = BH = EF = DJ = CI = 12 \text{ cm}$

calculate the angle that AJ makes with the base $ABHG$ of the prism.

Give your answer correct to 3 significant figures.

Compound measurements and Travel time graphs



By Kru ชี

A compound measure is made up of two or more different measurements

- Speed
- Density
- Force

Speed is a compound measure because $\text{speed} = \frac{\text{distance}}{\text{time}}$

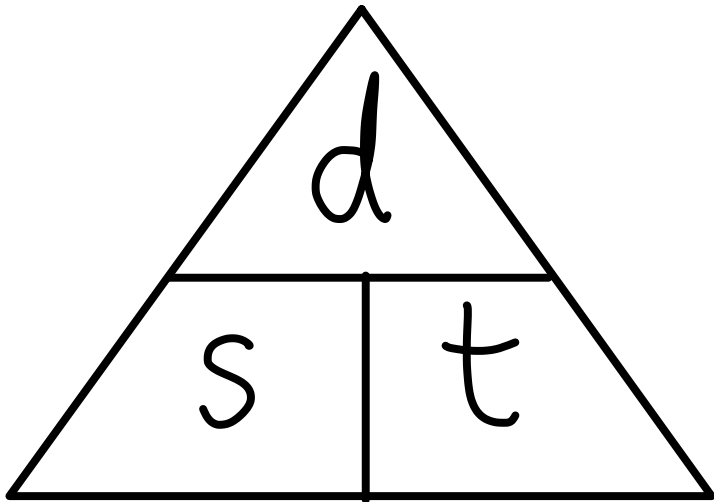

Density is the mass of a substance contained in a certain volumes

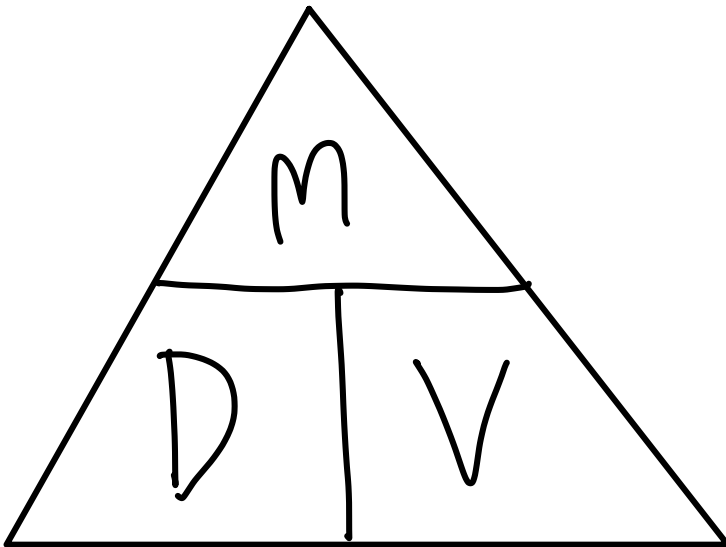

Pressure is the force applied over a certain area

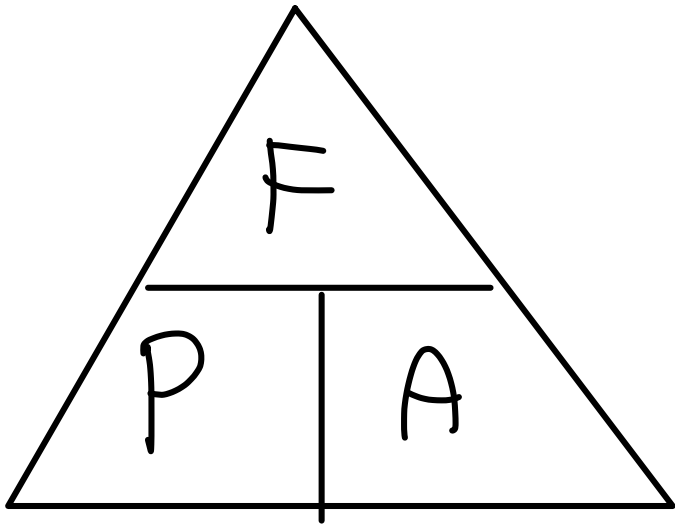

1. Change a speed of 50 metres per second to a speed in kilometres per hour.
2. Change a speed of 630 kilometres per hour to a speed in metres per second.

3. A solid metal sphere has radius 1.5 cm.
The mass of the sphere is 109.6 grams.

Work out the density of the sphere.

Give your answer correct to 3 significant figures.

4. The diagram shows a solid cuboid made from wood.

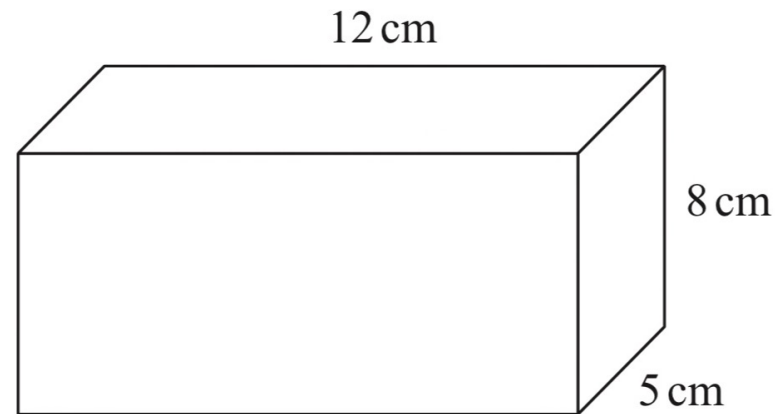

The wood has density 0.7 g/cm^3

Work out the mass of the cuboid.

5.

$$\text{pressure} = \frac{\text{force}}{\text{area}}$$

A box is put on a table.

The face of the box in contact with the table is in the shape of a rectangle, 2 m by 1.25 m.
The pressure on the table due to the box is 42 newtons/m²

Work out the force exerted by the box on the table.

6. Jalina left her home at 1000 to cycle to a park.
On her way to the park, she stopped at a friend's house and then continued her journey to the park.
Here is the distance-time graph for her journey to the park.

**Distance from
home (km)**

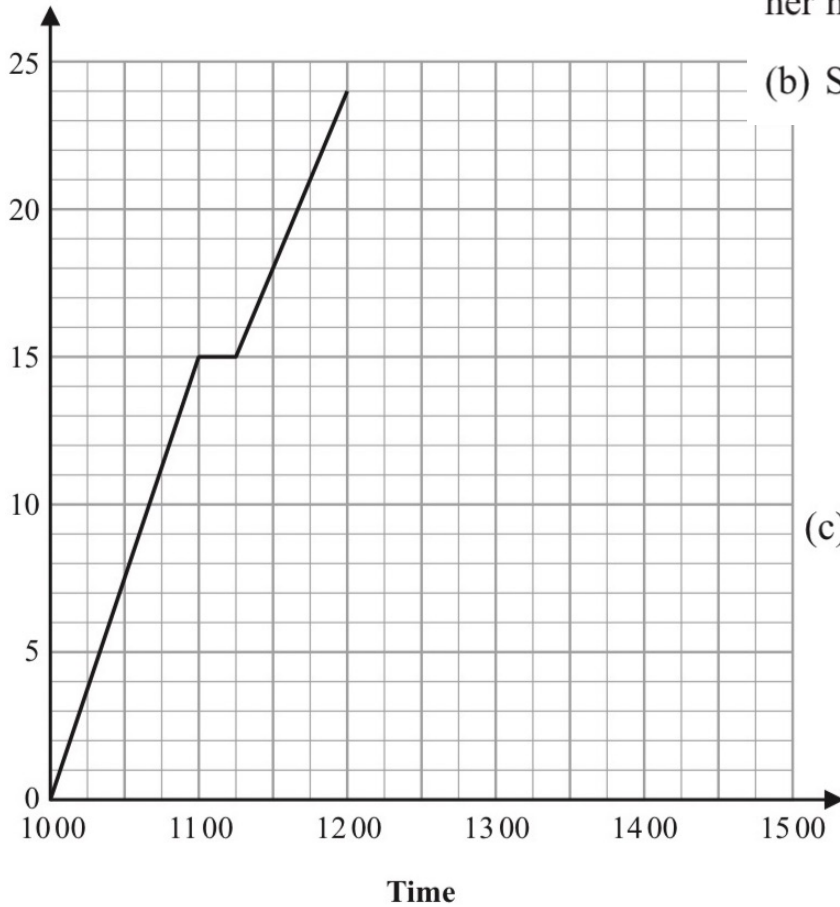

Jalina stayed at the park for 45 minutes.

She then cycled, without stopping, at a constant speed of 16 km/h from the park back to her home.

(b) Show all this information on the distance-time graph.

(c) Work out Jalina's average cycling speed, in kilometres per hour, for the complete journey to the park and back.

Do **not** include the times when she was not cycling in your calculation.

Give your answer correct to 1 decimal place.

7. The diagram shows a solid cube.
The cube is placed on a table so that the whole of one face of the cube is in contact with the table.

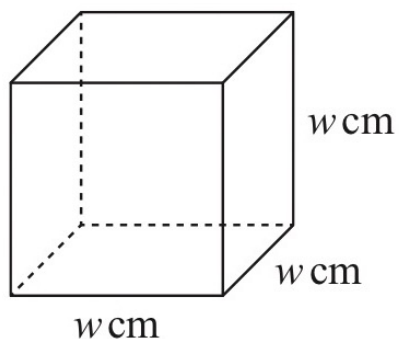

Diagram **NOT**
accurately drawn

The cube exerts a force of 56 newtons on the table.
The pressure on the table due to the cube is $0.14 \text{ newtons/cm}^2$

$$\text{pressure} = \frac{\text{force}}{\text{area}}$$

Work out the volume of the cube.

8.

$$\text{pressure} = \frac{\text{force}}{\text{area}}$$

A box, in the shape of a cuboid, is going to be put on a table.

The whole of one face of the box will be in contact with the table.

The force exerted by the box on the table is always 105 newtons.

The box is 5 m by 4 m by 3 m.

The greatest pressure exerted by the box on the table is P newtons/m²

The least pressure exerted by the box on the table is Q newtons/m²

Work out the value of $P - Q$

9. Abelle flew by plane from Dubai to Rome.

The flight time was 6 hours 42 minutes.

The average speed of the plane was 650 kilometres per hour.

Work out the distance the plane flew.

10. A plane takes 3 hours 36 minutes to fly from the Cayman Islands to New York.
The plane flies a distance of 2470 km.

Work out the average speed of the plane in km/h.

Give your answer correct to the nearest whole number.

11. The Shanghai Maglev Train takes 8 minutes to travel a distance of 30.5 kilometres.

Work out the average speed of the train.

Give your answer in kilometres per hour.

12. Pedro drove from Toulouse to Montpellier in 2 hours 42 minutes.
He drove at an average speed of 90 km/hour.

Janine drove from Toulouse to Montpellier along the same route as Pedro.
The journey took her 3 hours.

Work out Janine's average speed for the journey.

13. The diagram shows a solid made from a cylinder and a hemisphere.
The cylinder and the hemisphere are both made from the same metal.

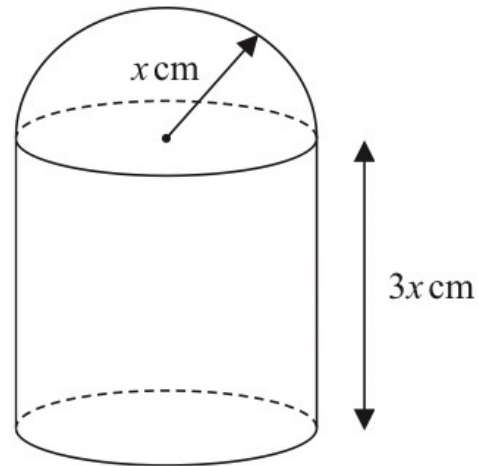

The plane face of the hemisphere coincides with the upper plane face of the cylinder.

The radius of the cylinder and the radius of the hemisphere are both $x \text{ cm}$.
The height of the cylinder is $3x \text{ cm}$.

The total surface area of the solid is $81\pi \text{ cm}^2$
The mass of the solid is 840 grams.

The following table gives the density of each of four metals.

Metal	Density (g/cm^3)
Aluminium	2.7
Nickel	8.9
Gold	19.3
Silver	10.5

The metal used to make the solid is one of the metals in the table.

Determine the metal used to make the solid.
Show your working clearly.

14. A 3-D shape consists of a hollow sphere made of metal.



The diagram shows a cross section drawn through the centre, O , of the sphere.

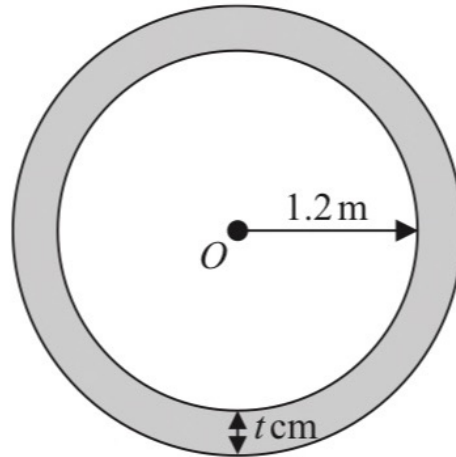

The internal radius of the sphere is 1.2 m .
The thickness of the metal is $t\text{ cm}$.

The density of the metal is 2700 kg per m^3

The mass of the 3-D shape is 1980 kg .





Work out the value of t .

Give your answer correct to 2 significant figures.

Symmetry

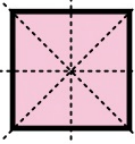

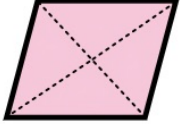
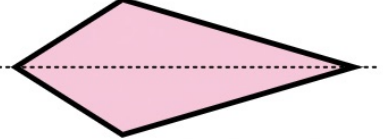
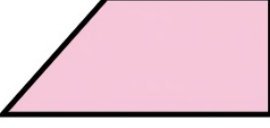
By Kru ชี

Quadrilateral	Image	Number of Lines of Symmetry
Square		4
Rectangle		2
Parallelogram		0
Rhombus		2
Kite		1
Trapezium		0
Isosceles Trapezium		1

Lines of symmetry in regular polygons

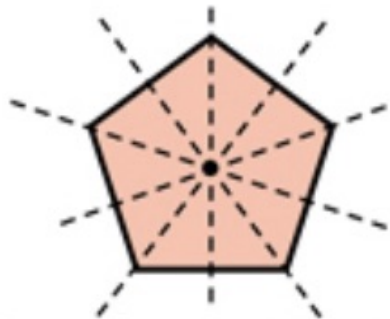

Regular Pentagon
Five lines of Symmetry

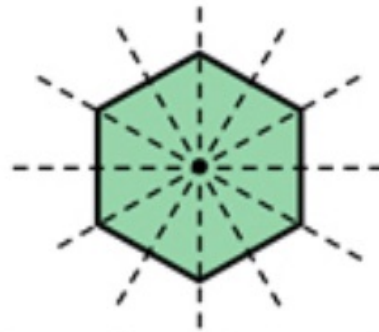

Regular Hexagon
Six lines of Symmetry

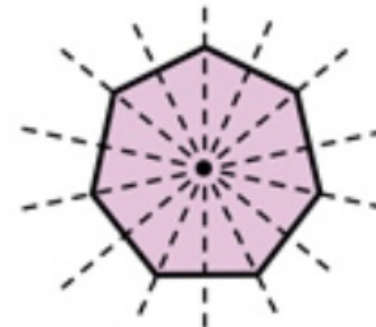

Regular Heptagon
Seven lines of Symmetry

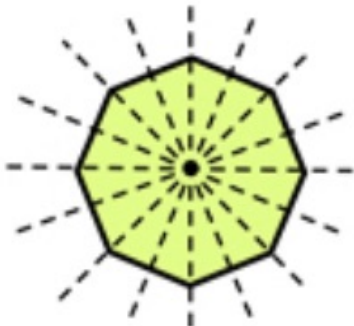

Regular Octagon
Eight lines of Symmetry

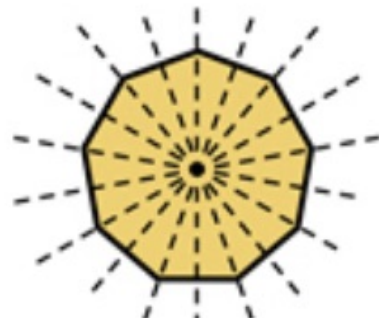

Regular Nonagon
Nine lines of Symmetry

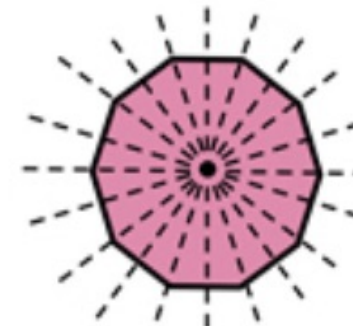

Regular Decagon
Ten lines of Symmetry

What is rotational symmetry ?

Rotational symmetry is the number of times a shape can “fit into itself” when it is rotated **360** degrees about its centre.

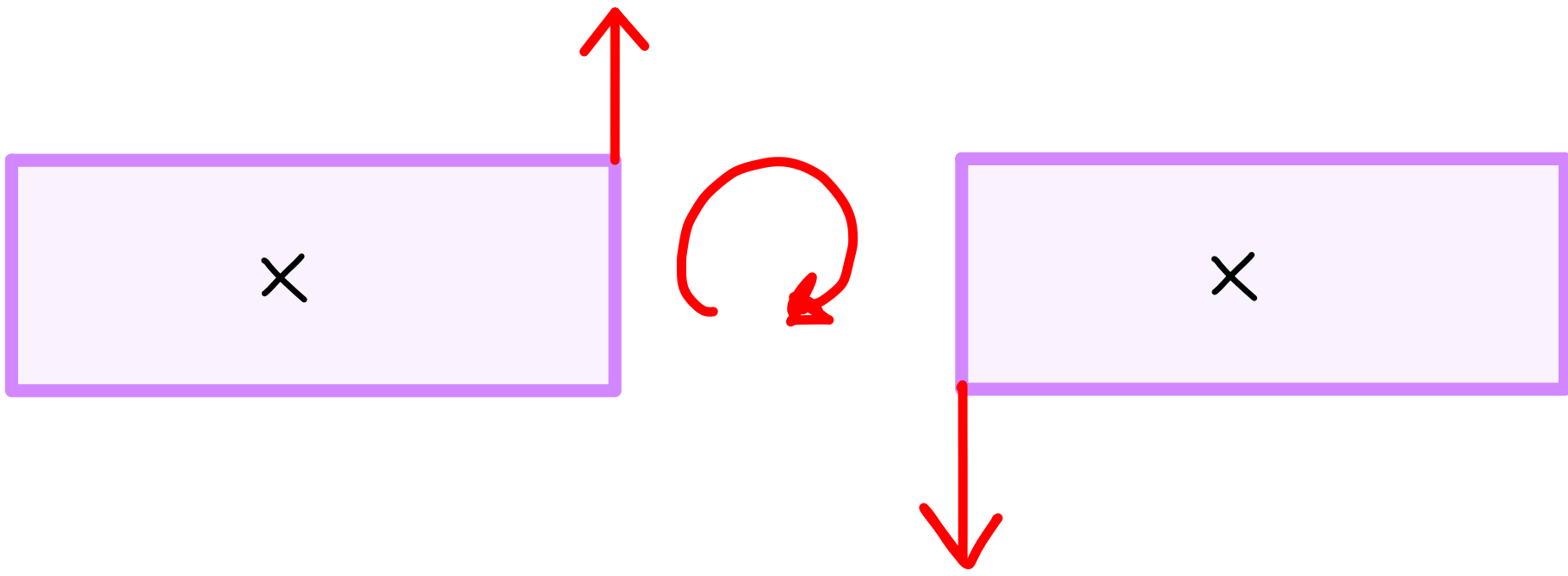

Rectangle

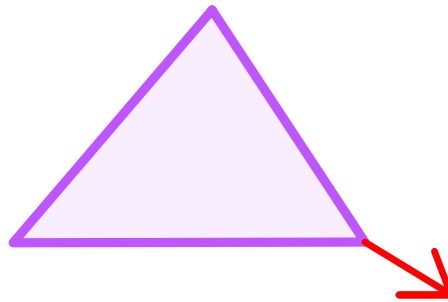
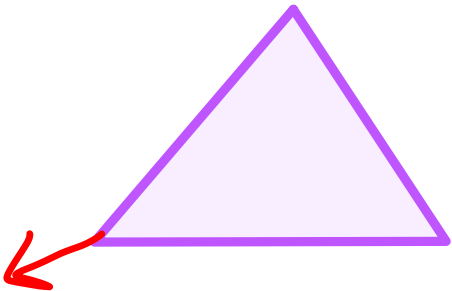
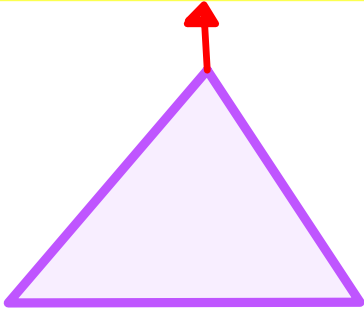

Order 2

Equilateral Triangle

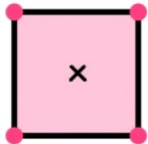
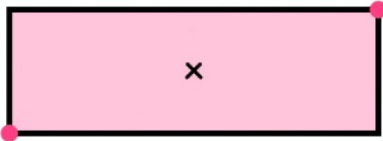
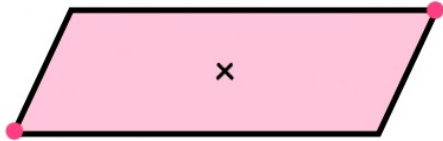
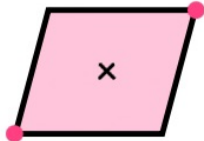
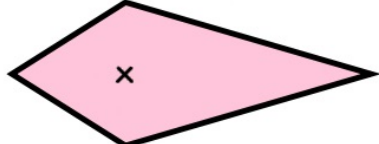
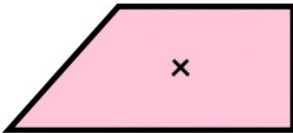

Quadrilateral	Image	Order of Rotational Symmetry
Square		4
Rectangle		2
Parallelogram		2
Rhombus		2
Kite		0
Trapezium		0
Isosceles Trapezium		0

Rotational symmetry in regular polygons

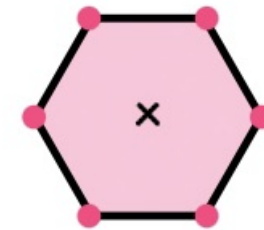
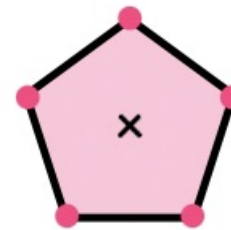
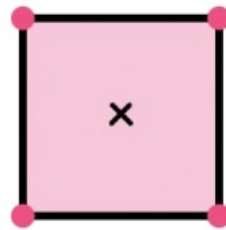
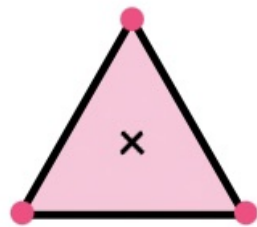

2D Polygon	Equilateral Triangle	Square	Regular Pentagon	Regular Hexagon
Order of Rotational Symmetry	3	4	5	6

Construction



By Kru ชี



For construction

- Ruler
- Pencil
- Compass
- Protractor

- Constructions are accurate drawings of shapes, angles and lines in geometry

1. Perpendicular bisector of a line



2. Perpendicular from given point to a line

Point is outside a line

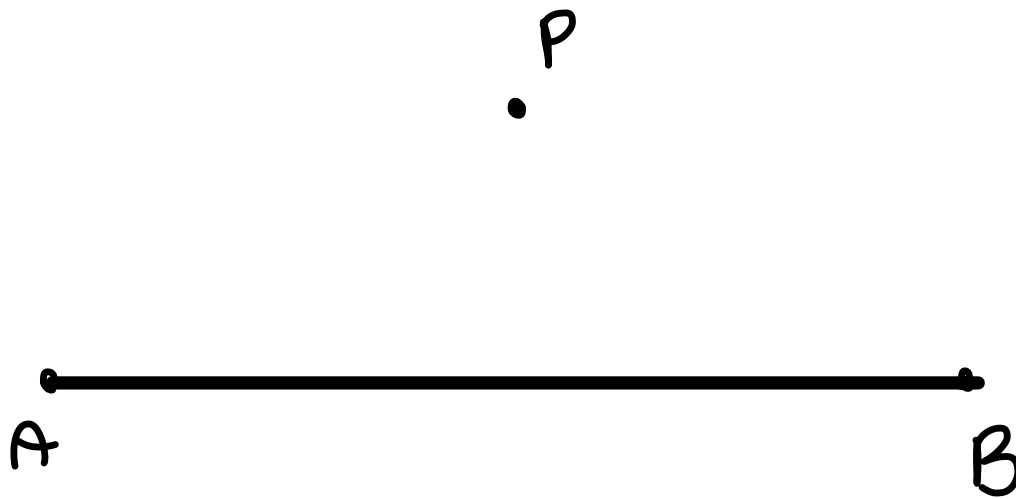

2. Perpendicular from given point to a line

Point is on a line

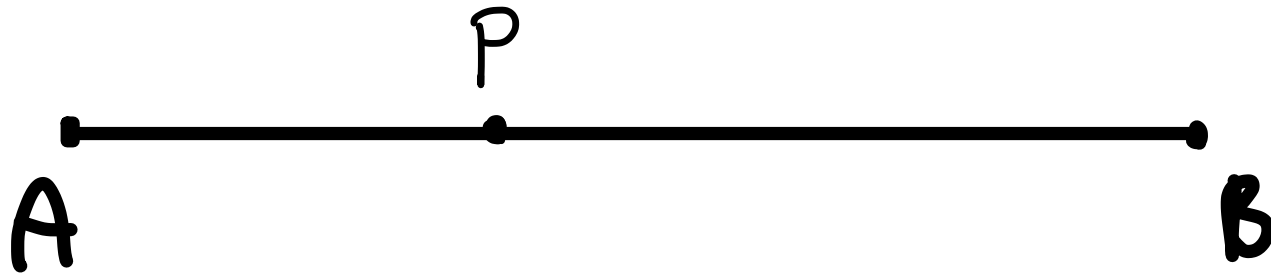

3. Bisector of angle

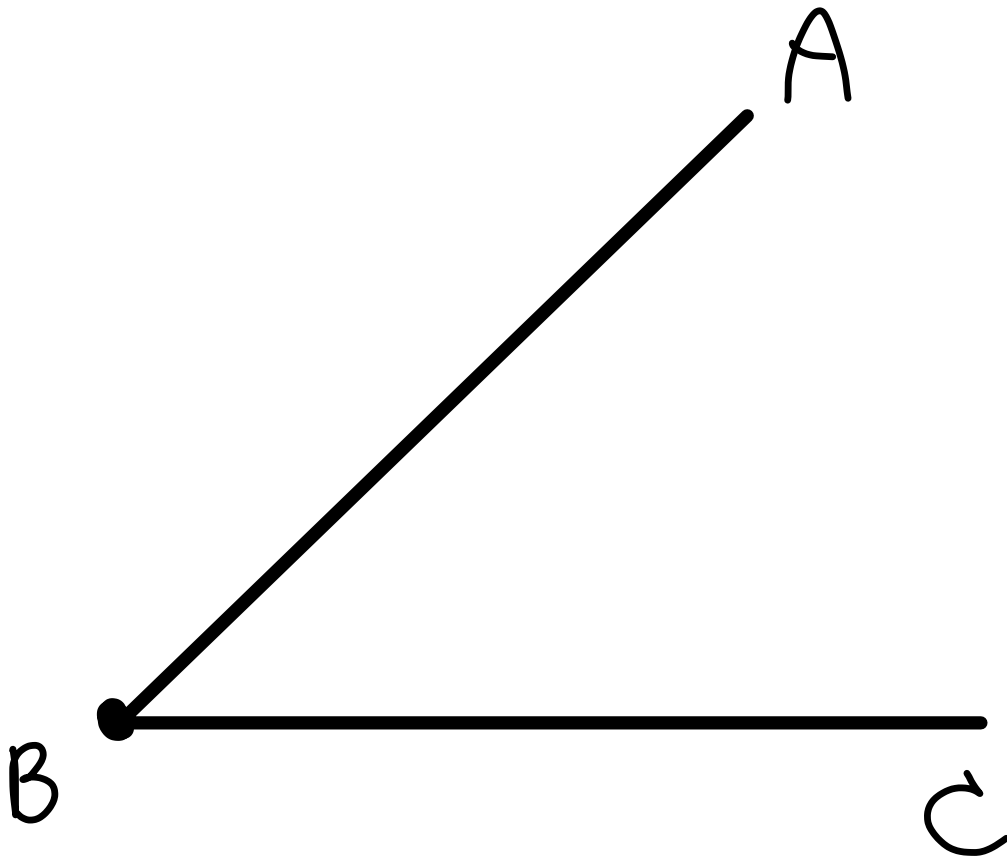

4. Equilateral triangle

Example : Draw equilateral triangle with each side is 6 cm

1. Use ruler and compasses only to construct the perpendicular bisector of the line AB . You must show all your construction lines.

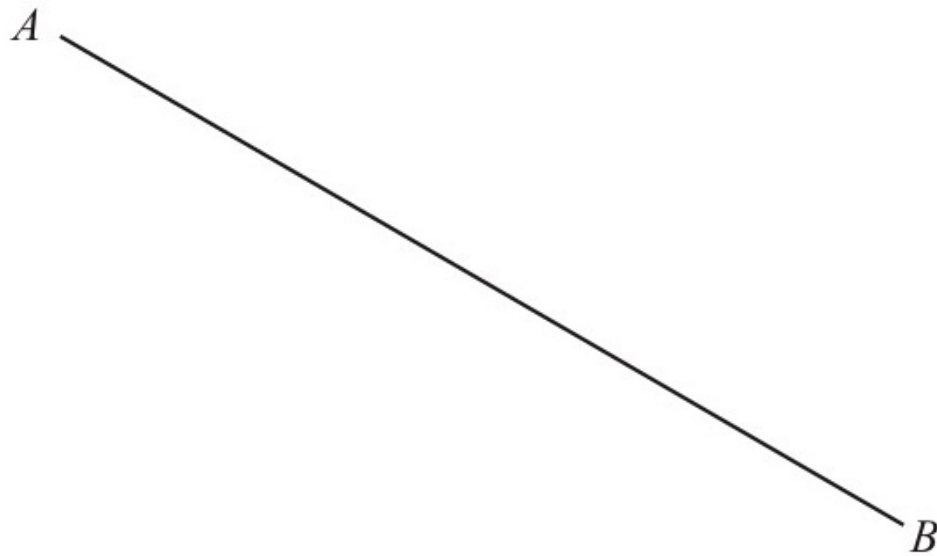

2. Use ruler and compasses to construct the bisector of angle BAC .
You must show all your construction lines.

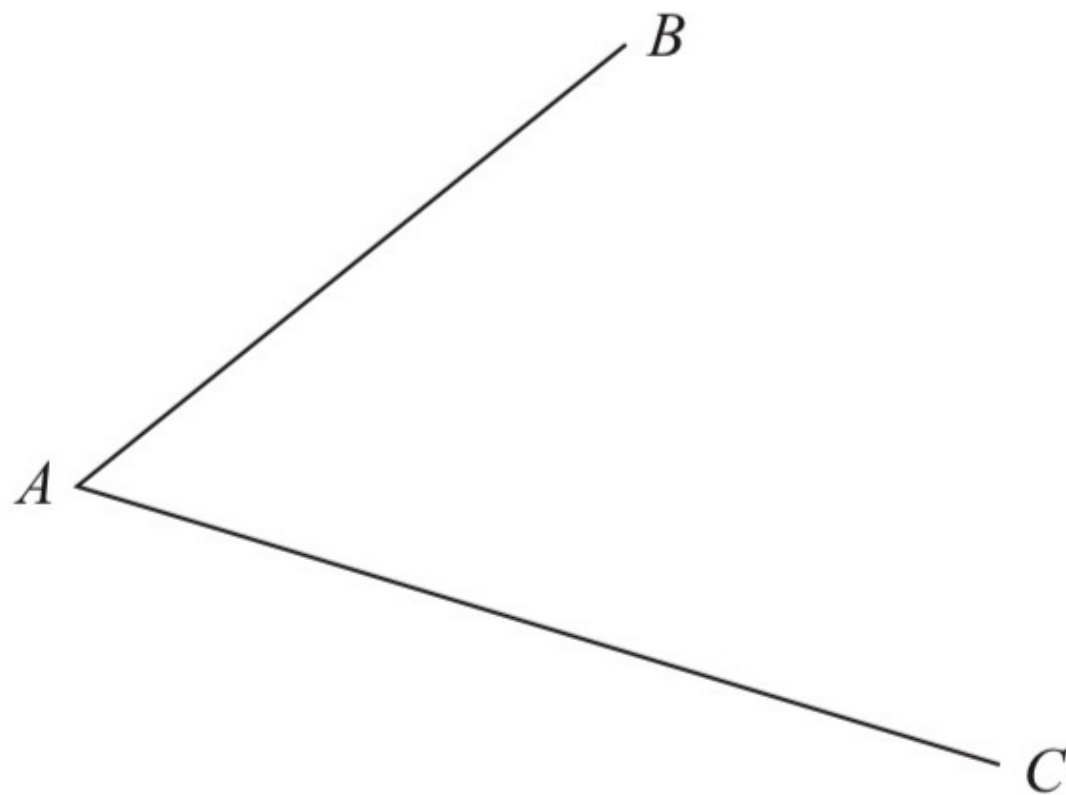

Transformation



By Kru ชี

Types of transformations

1. Translation

2. Reflection

3. Rotation

4. Enlargement (positive & negative scale factor)

Translation

translation: 5 units right and 1 unit up

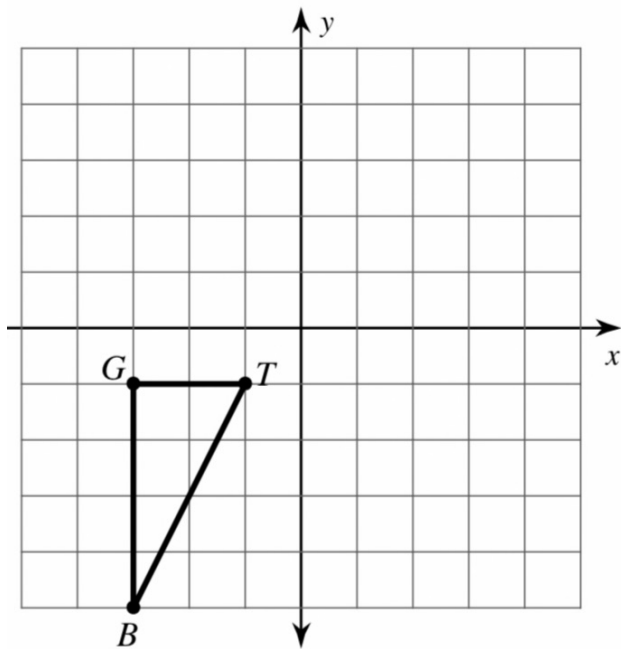

Describe the transformation of the black shape to its image (blue shape)

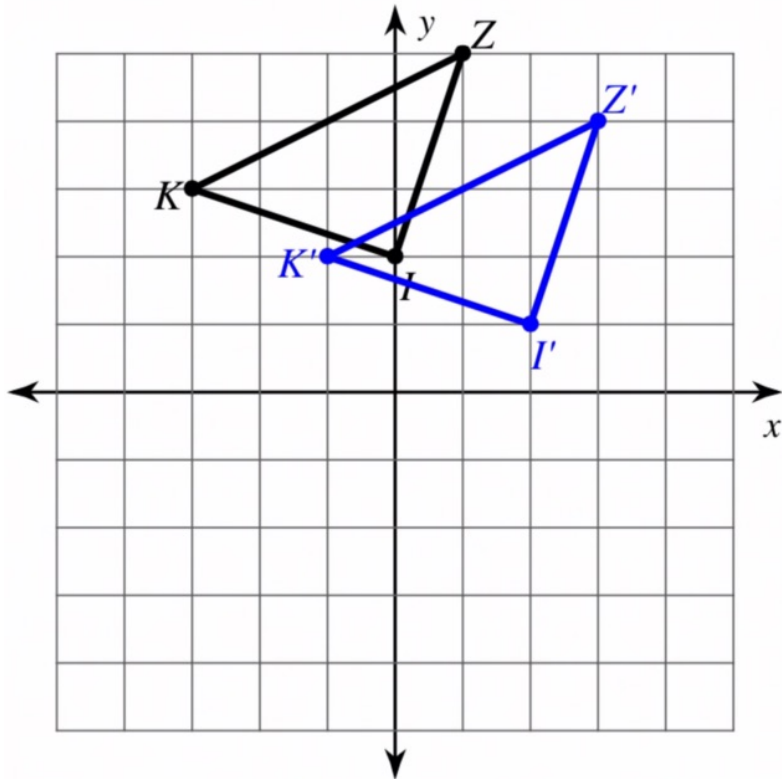

Reflection

Reflection is a type of transformation that flips a shape in a mirror line (also called a line of reflection) so that each point is the same distance from the mirror line as its reflected point.

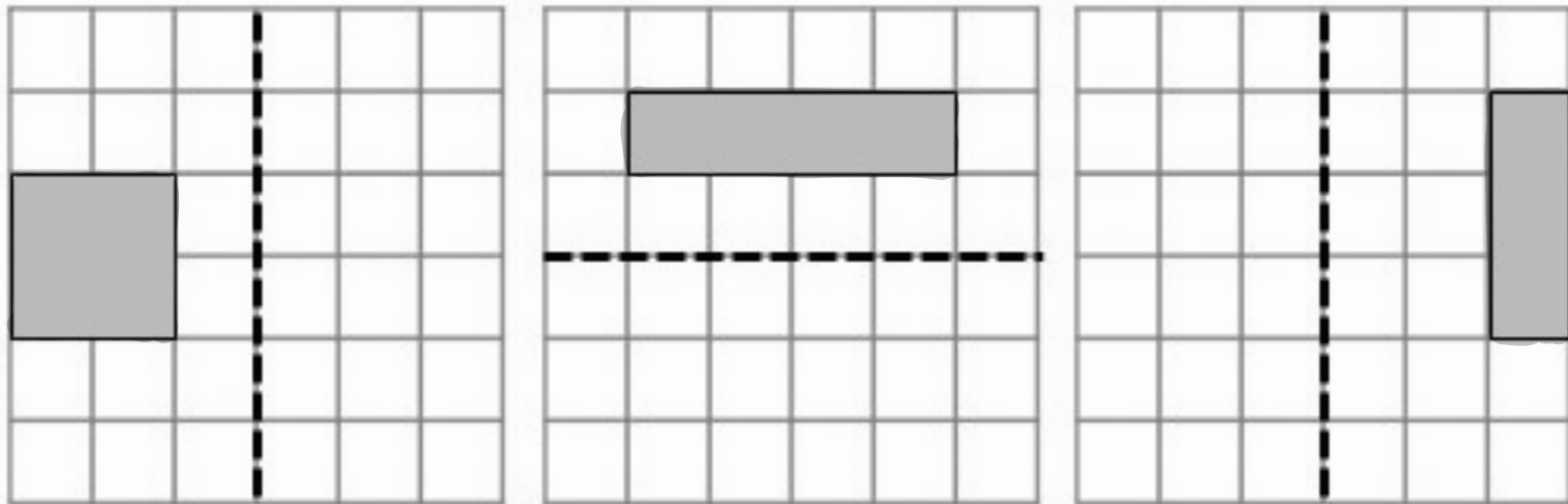

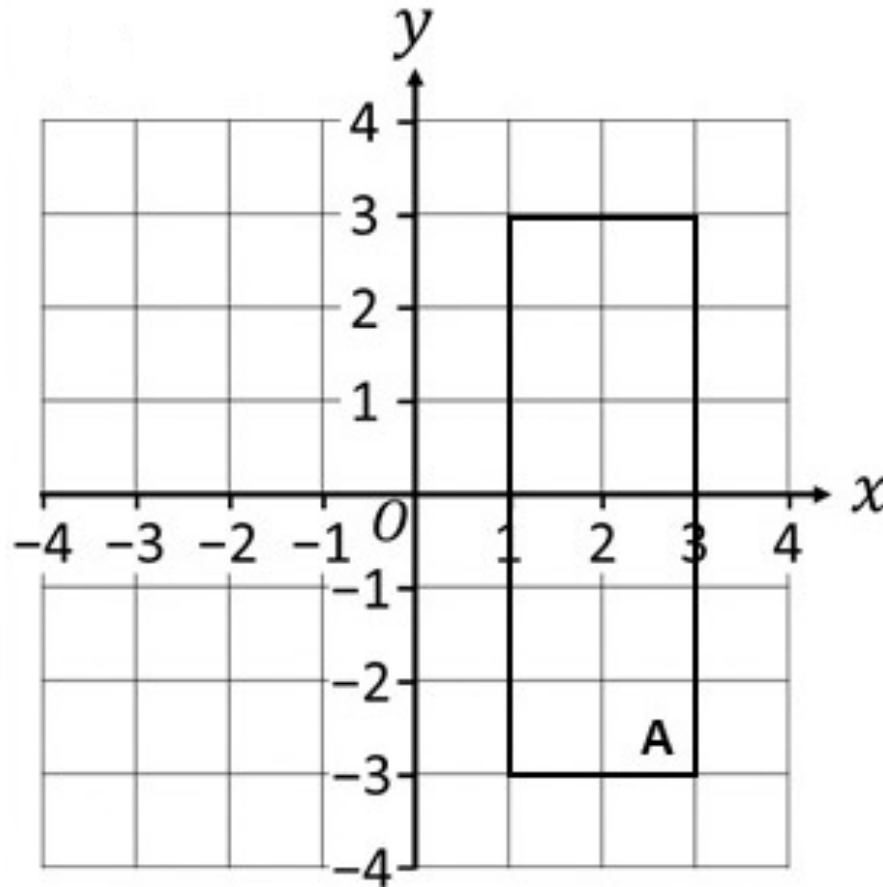

Reflect Shape **A** in the y axis.

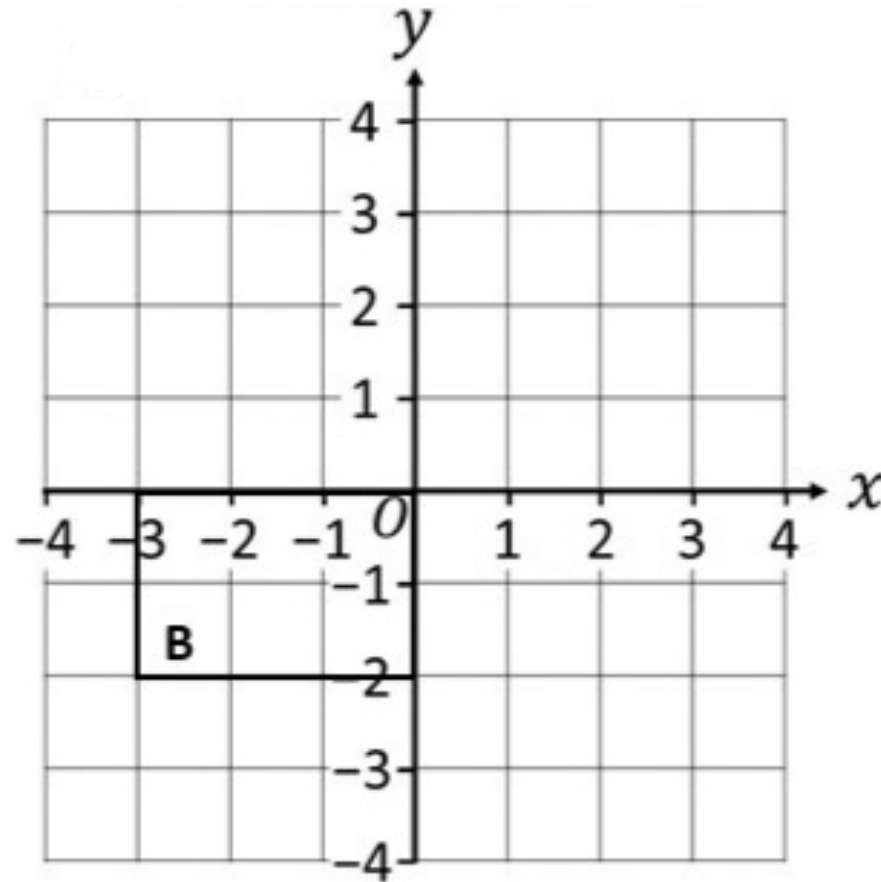

Reflect Shape **B** in the line $y = 1$

Reflection: Across Line $y = x$

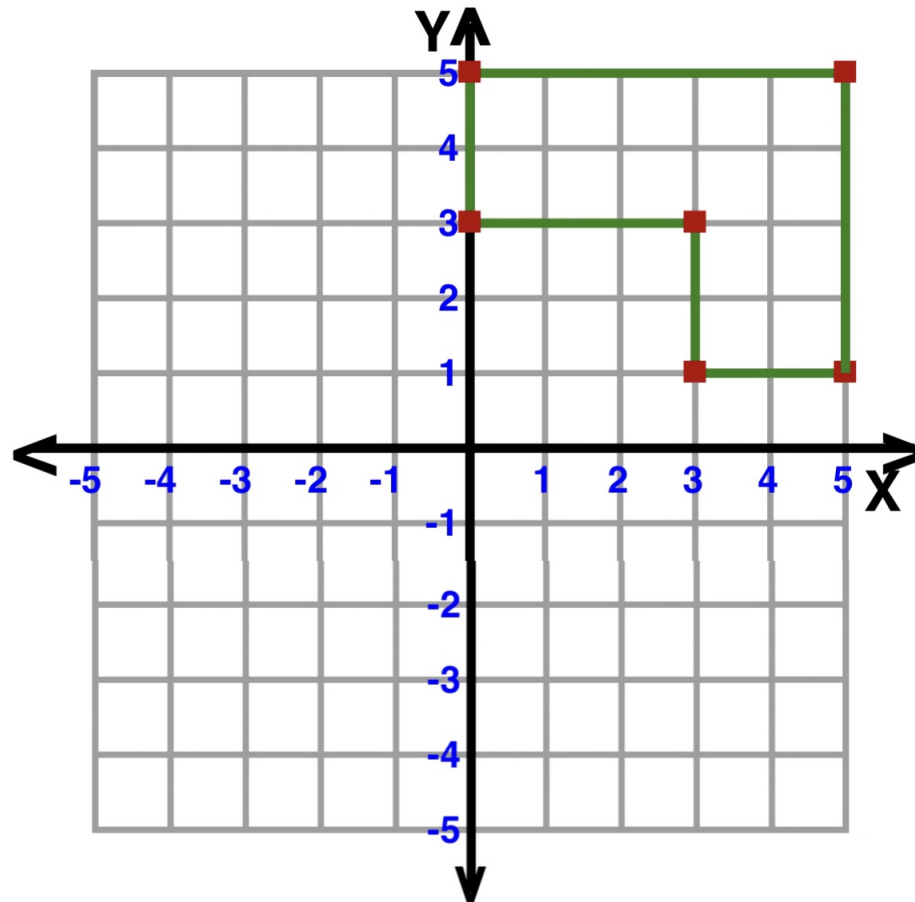

Reflection: Across Line $y = -x$

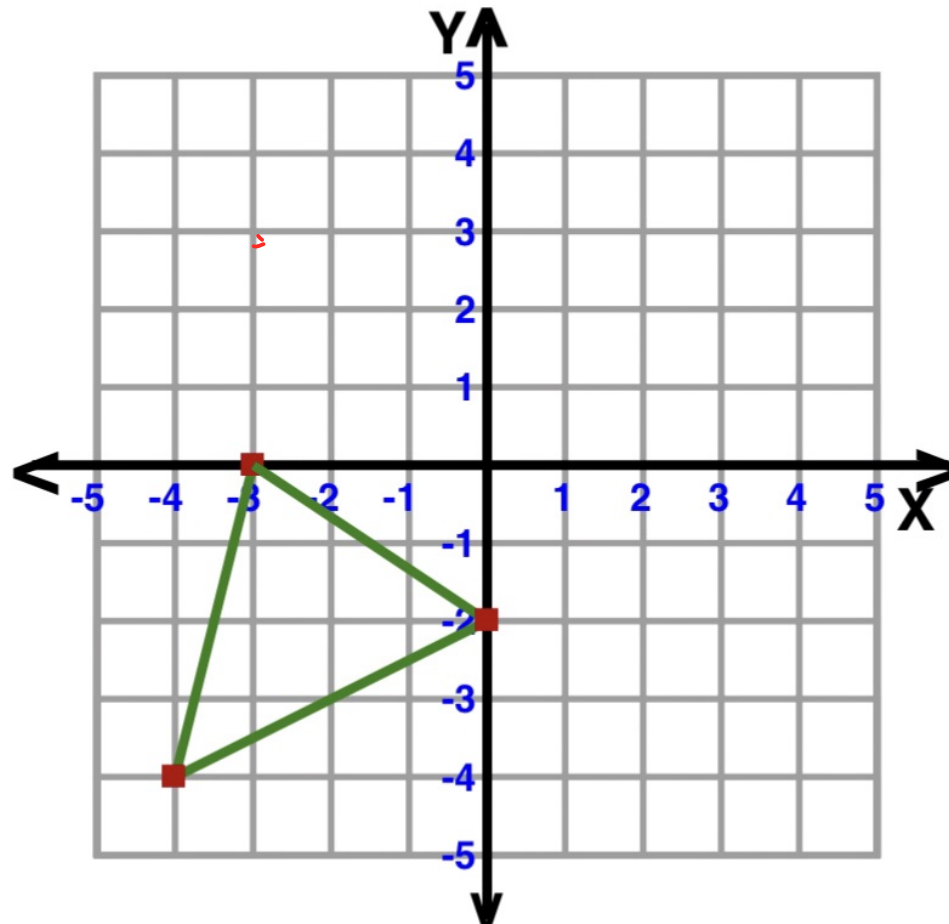

Rotation

Rotation is transformation that turn a shape around a fixed point

To rotation a shape we need

1. A centre of rotation
2. An angle of rotation
3. The direction of rotation



Clockwise



Anti-clockwise

Clockwise

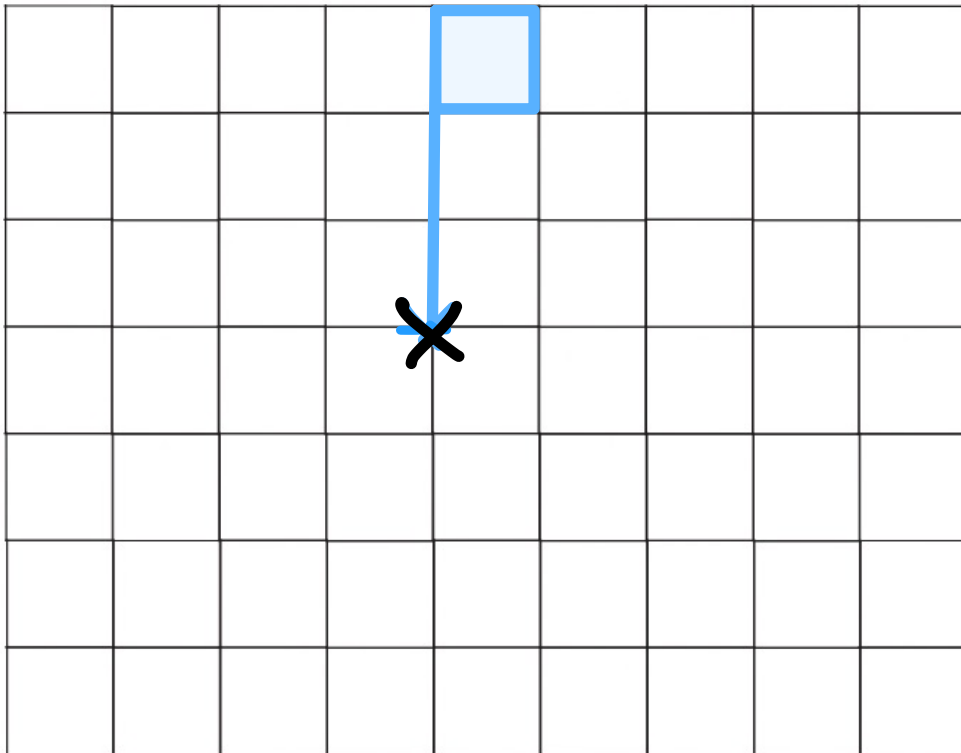

Anti-clockwise

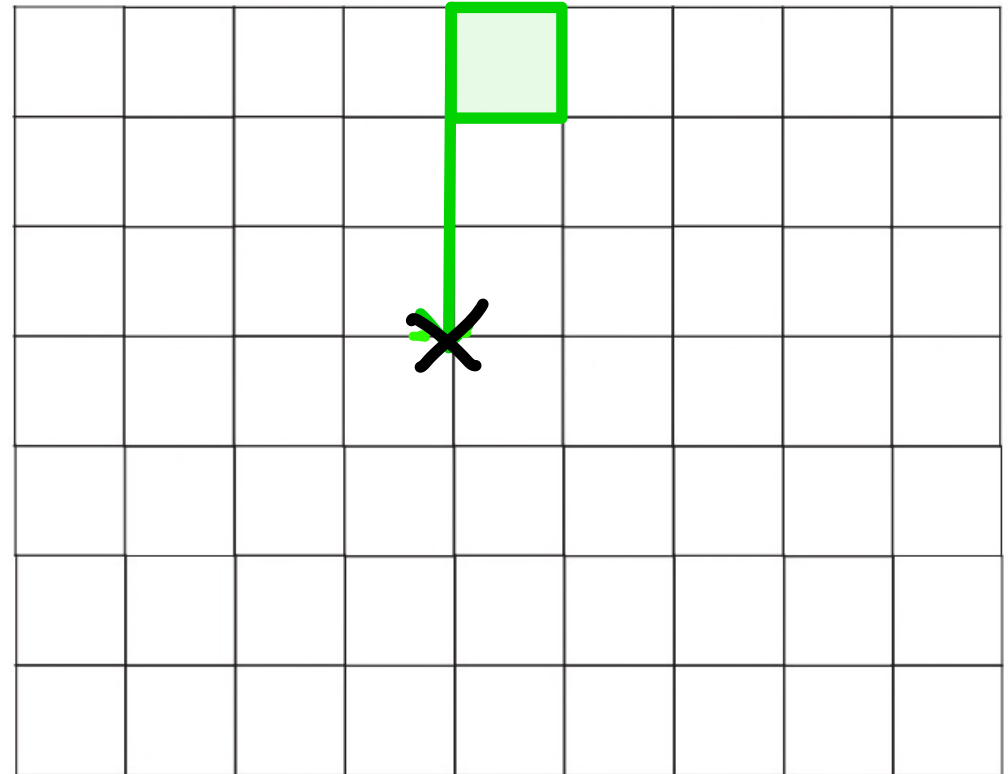

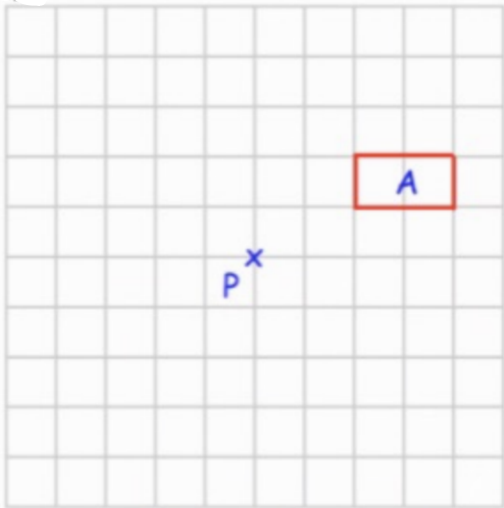

rotate 90° clockwise about P

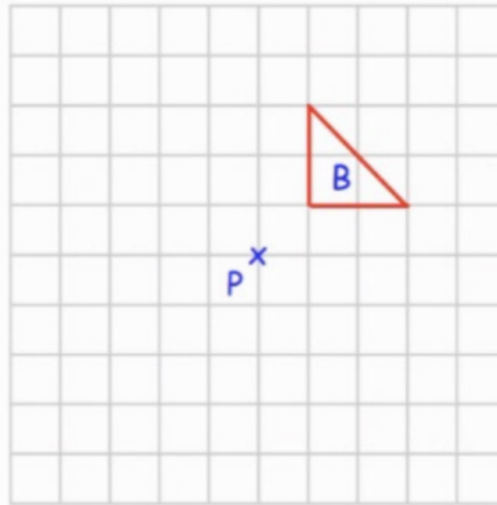

rotate 90° anticlockwise about P

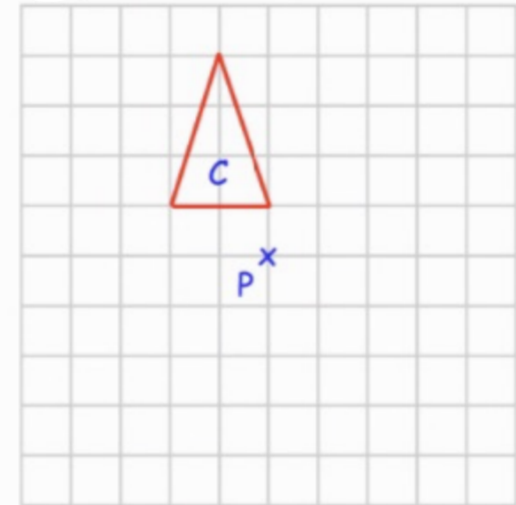

rotate 90° clockwise about P

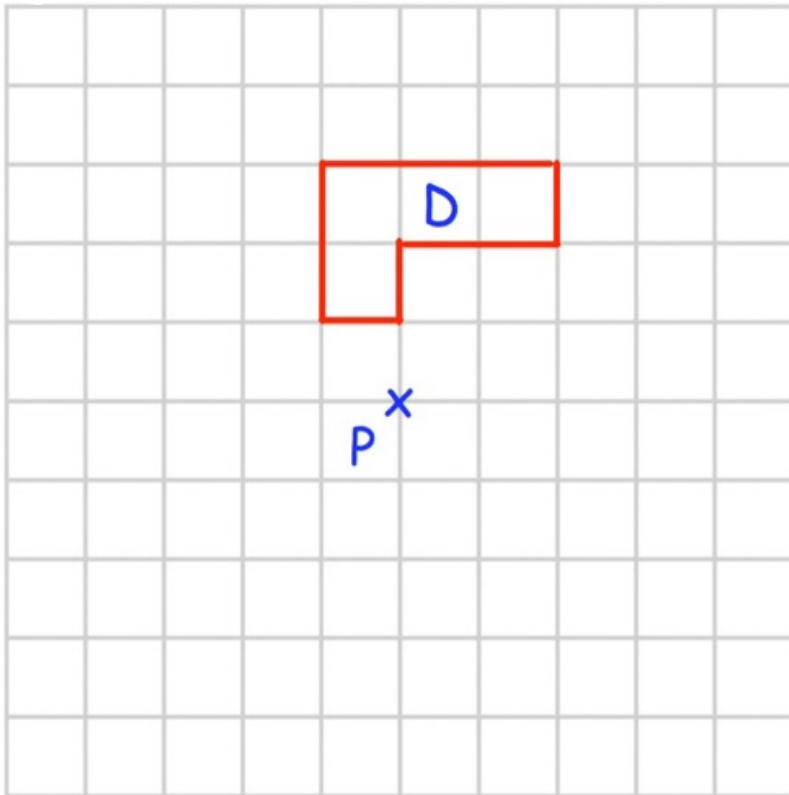

rotate 180° about P

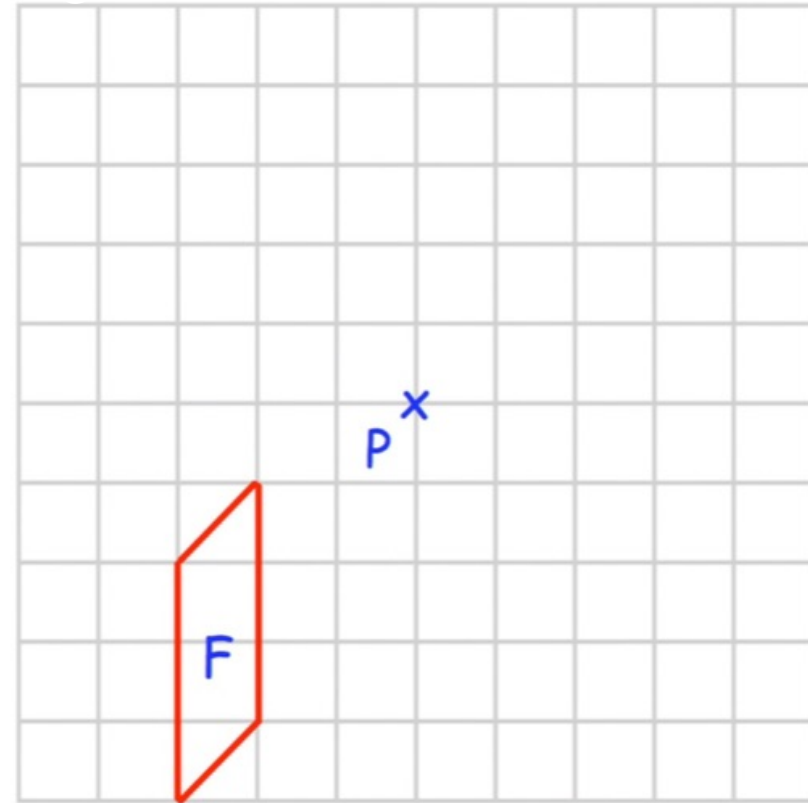

rotate 180° about P

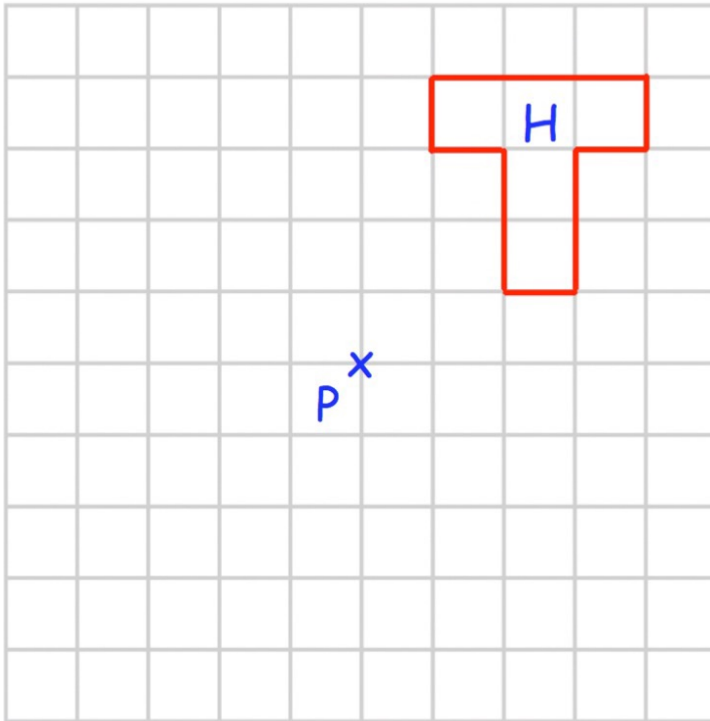

rotate 270° clockwise about P

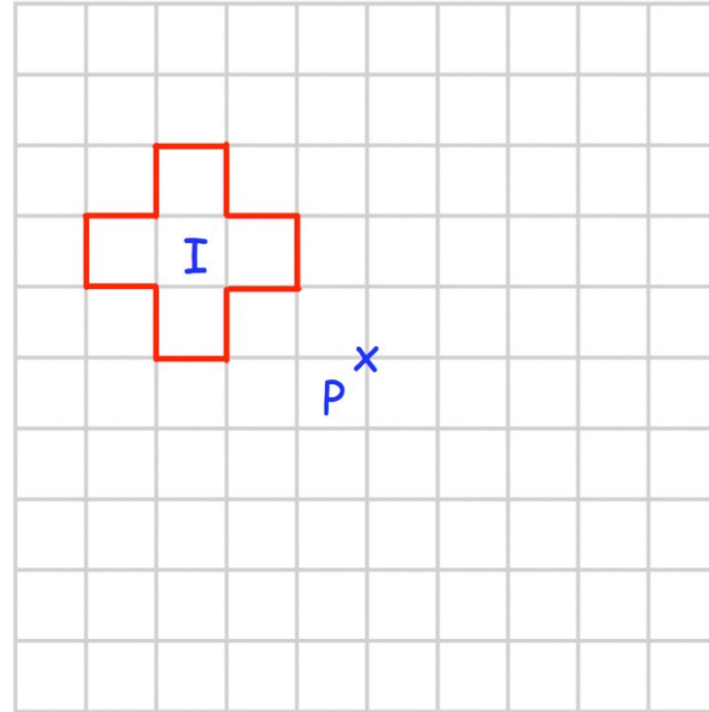

rotate 270° anticlockwise about P

Describe fully the single transformation that takes shape A to shape B.

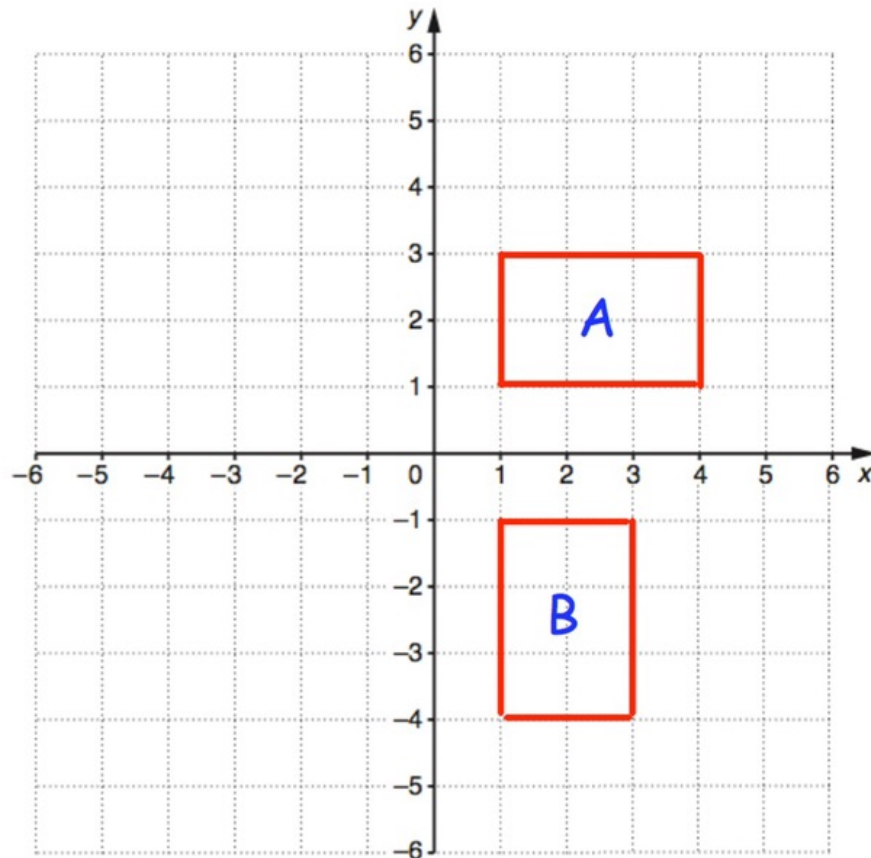

***YOU NEED TO FIND
CENTRE OF ROTATION***

Describe fully the single transformation that takes shape A to shape B.

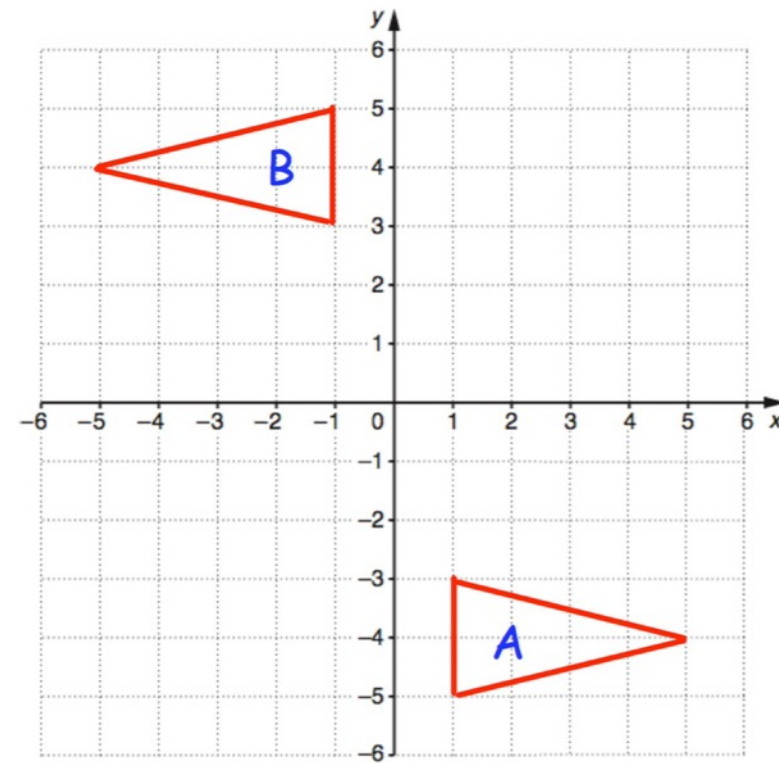
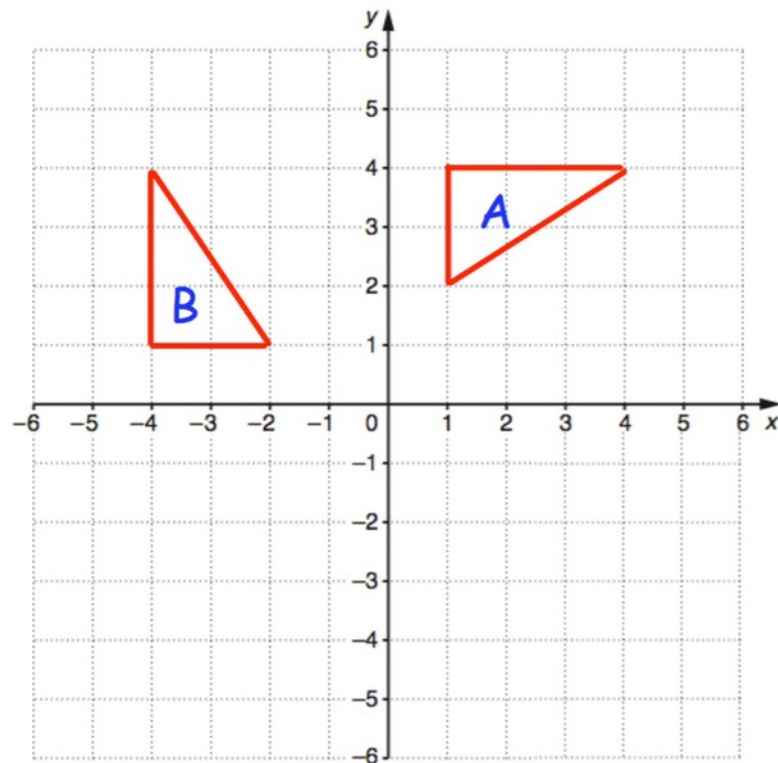

Enlargement

Enlarging a shape changes its size.

To enlarge a shape we need

1. Scale factor
2. Centre of enlargement

How to draw enlargement when scale factor and centre given

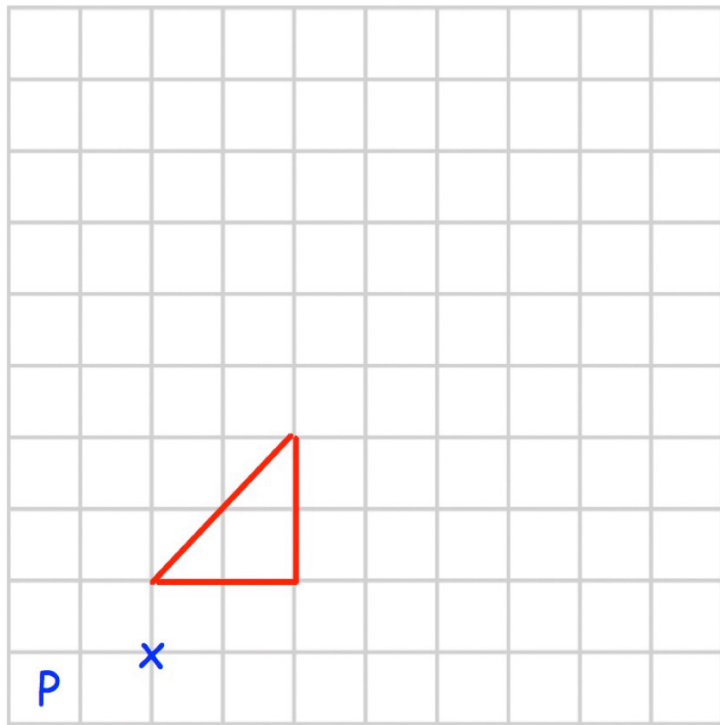

Enlarge by scale factor 3

Describe fully the single transformation that takes shape A to shape B.

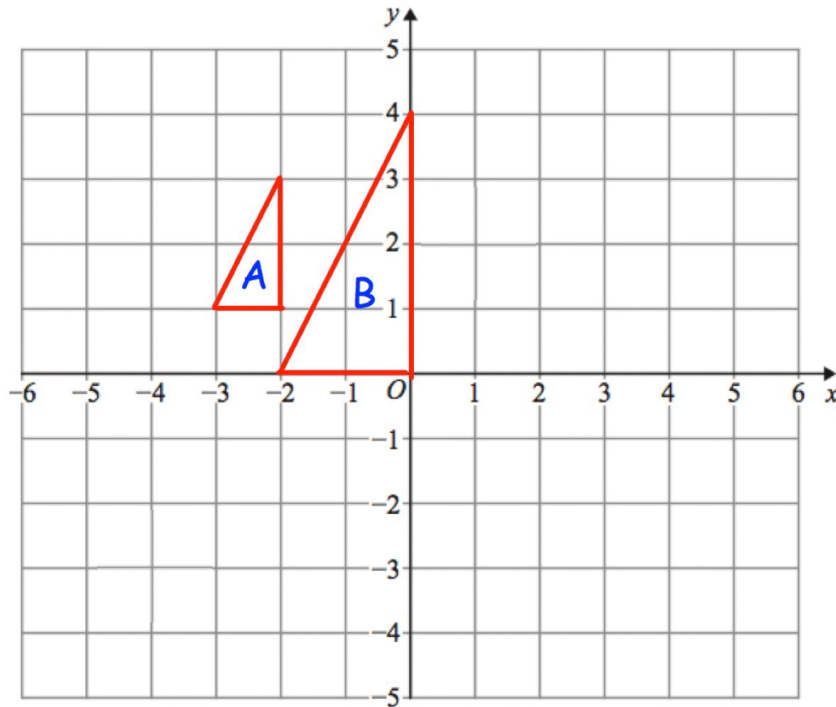

You need to find
CENTRE of enlargement

Enlargement with **NEGATIVE** scale factor



When you enlarge any shape with negative scale factor , shape with flip into opposite side of centre of enlargement

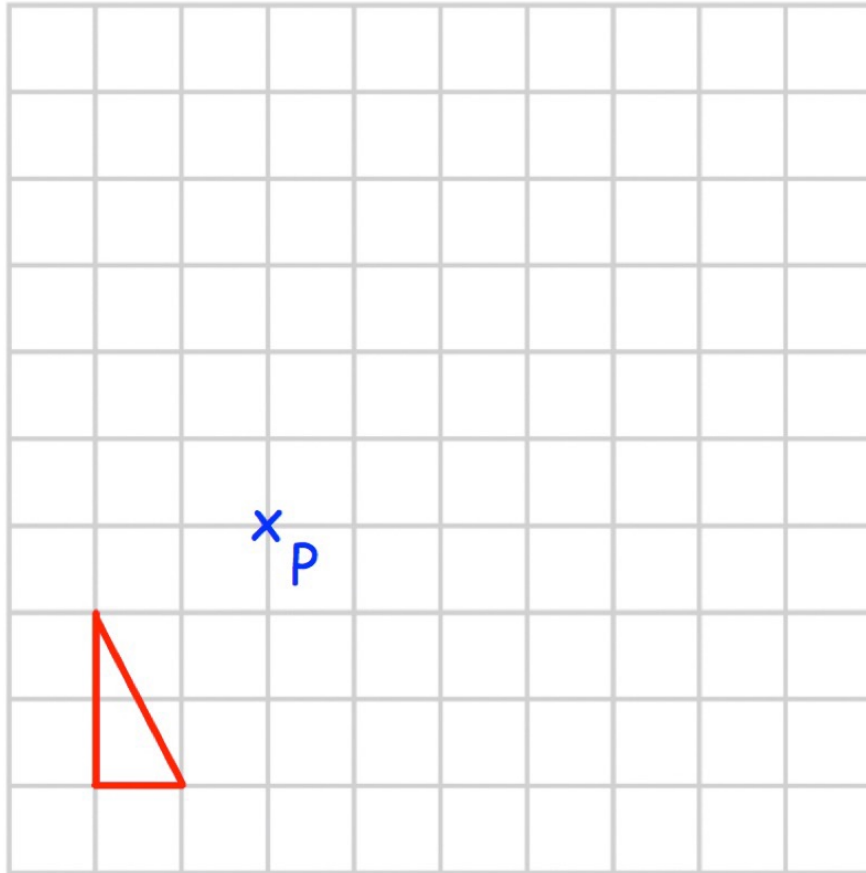

Enlarge by scale factor -2

Describe fully the single transformation that takes shape A to shape B.

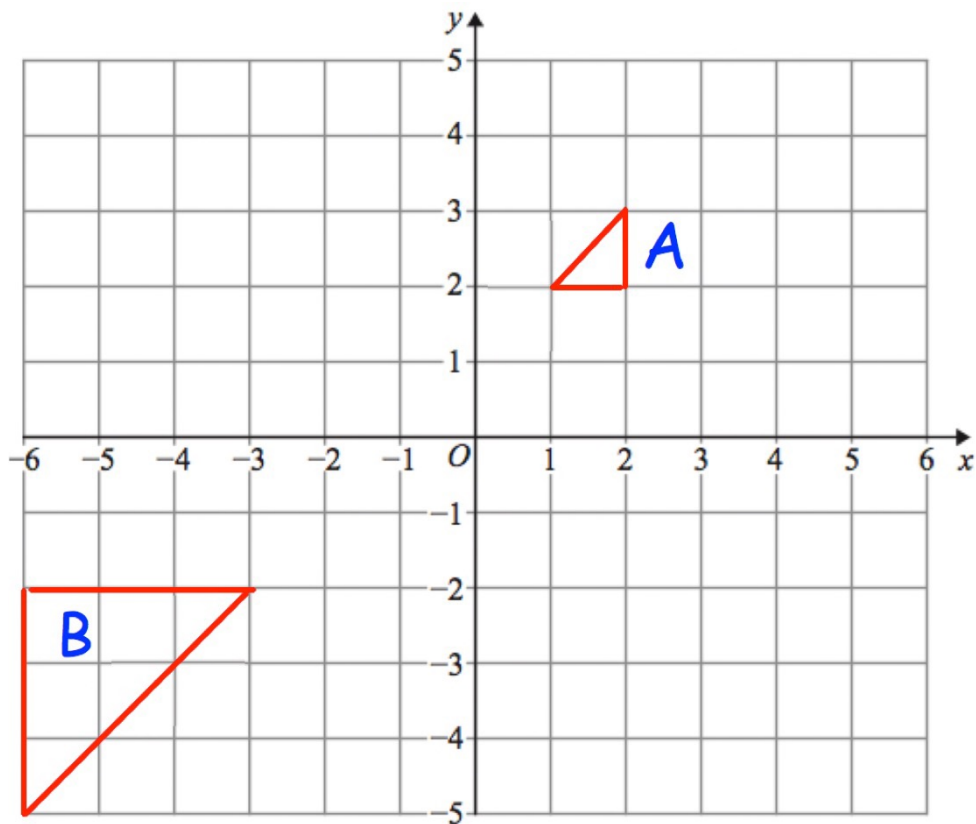

1.

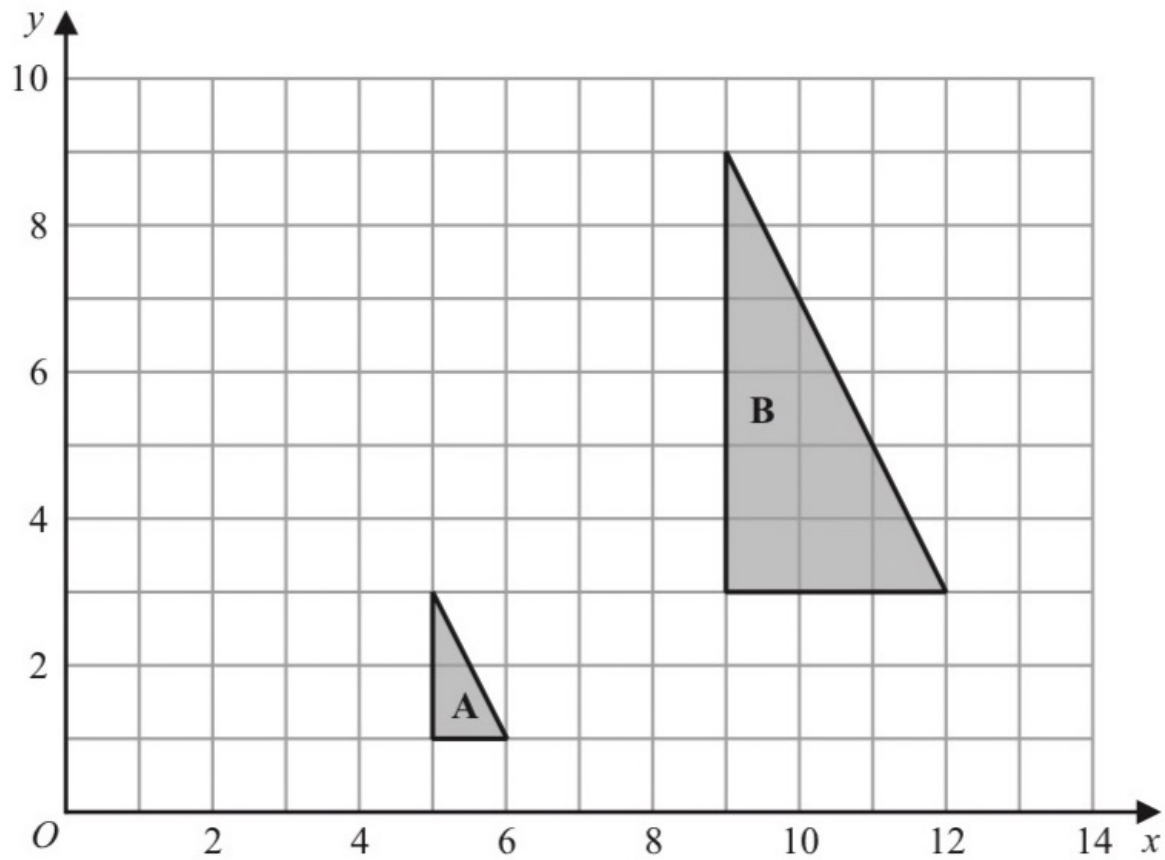

(a) Describe fully the single transformation that maps triangle **A** onto triangle **B**

.....

.....

(b) On the grid above, translate triangle **A** by the vector $\begin{pmatrix} -4 \\ 3 \end{pmatrix}$

Label your triangle **C**

2.

Here are triangle **T** and triangle **U** drawn on a grid of squares.

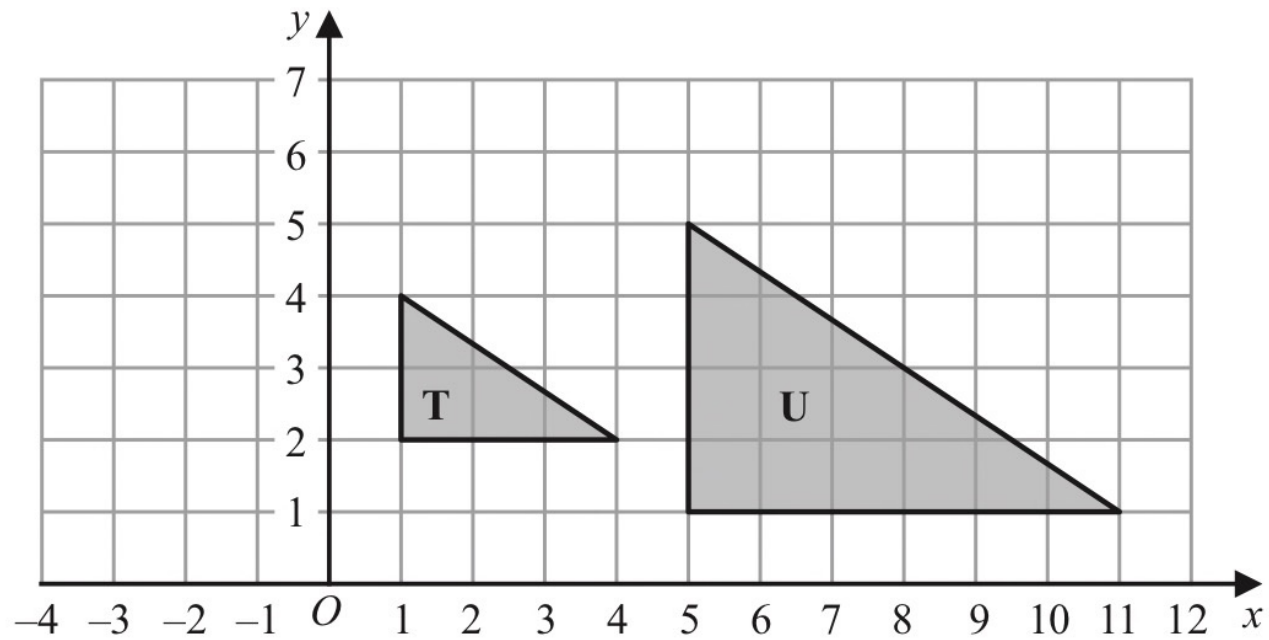

Describe fully the single transformation that maps triangle **T** onto triangle **U**.

.....

.....

3. Here is a shape **P** drawn on a grid of squares.

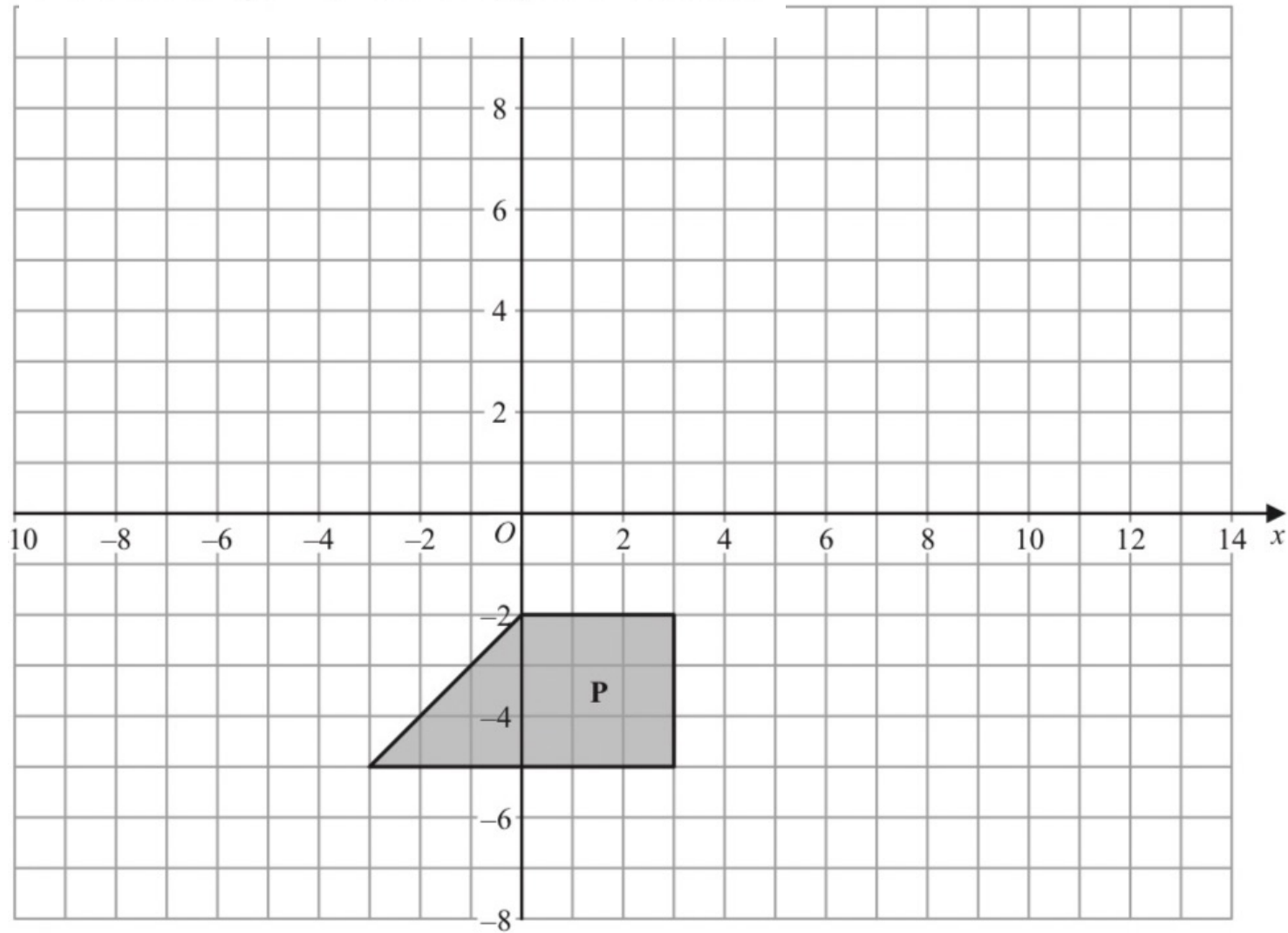

(a) On the grid, rotate shape **P** 180° about the point $(-3, 2)$
Label the new shape **Q**.

(2)

(b) On the grid, translate shape **P** by the vector $\begin{pmatrix} 10 \\ 8 \end{pmatrix}$
Label the new shape **R**.

(1)

4.

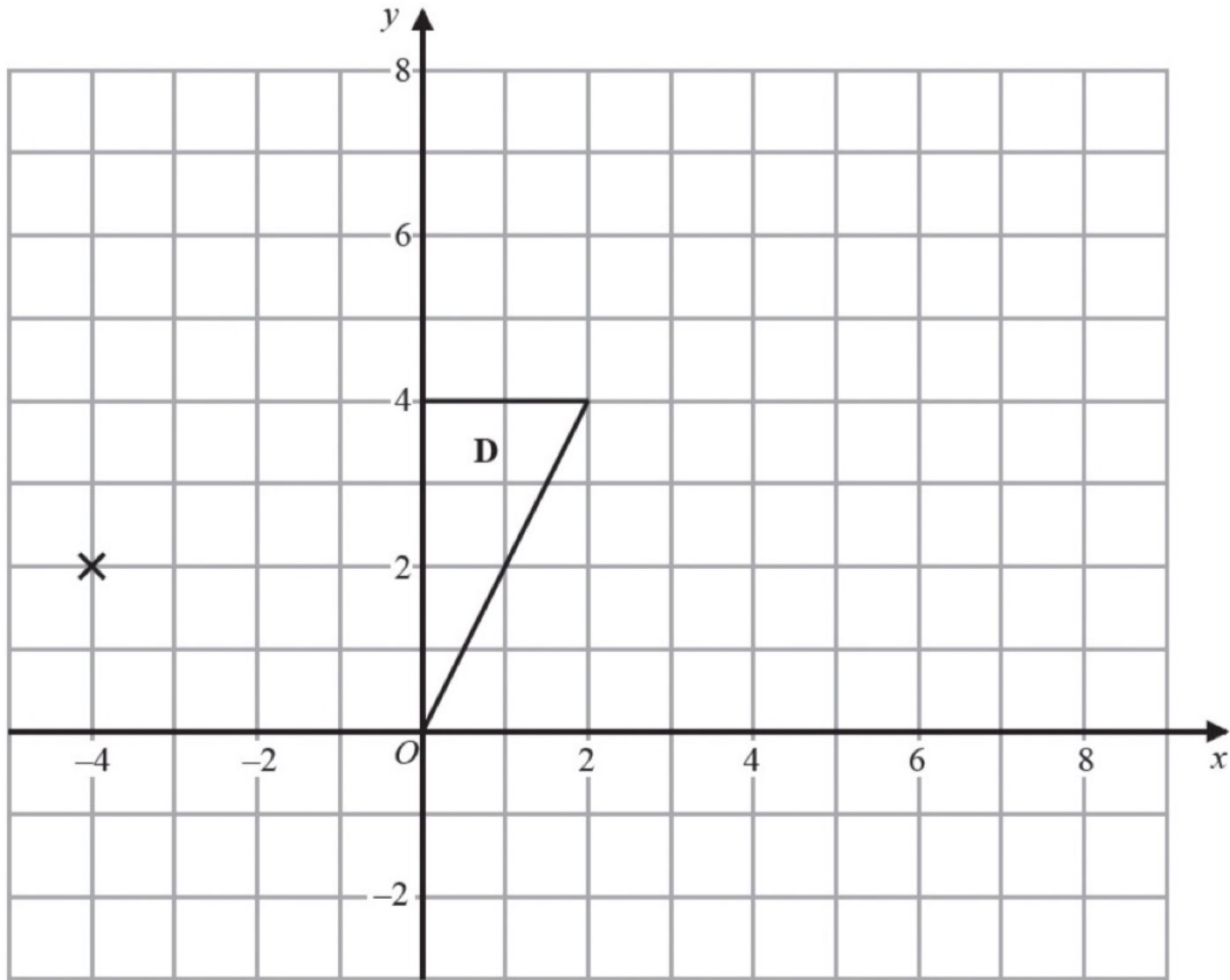

On the grid, enlarge triangle **D** with scale factor $\frac{1}{2}$ and centre $(-4, 2)$

5.

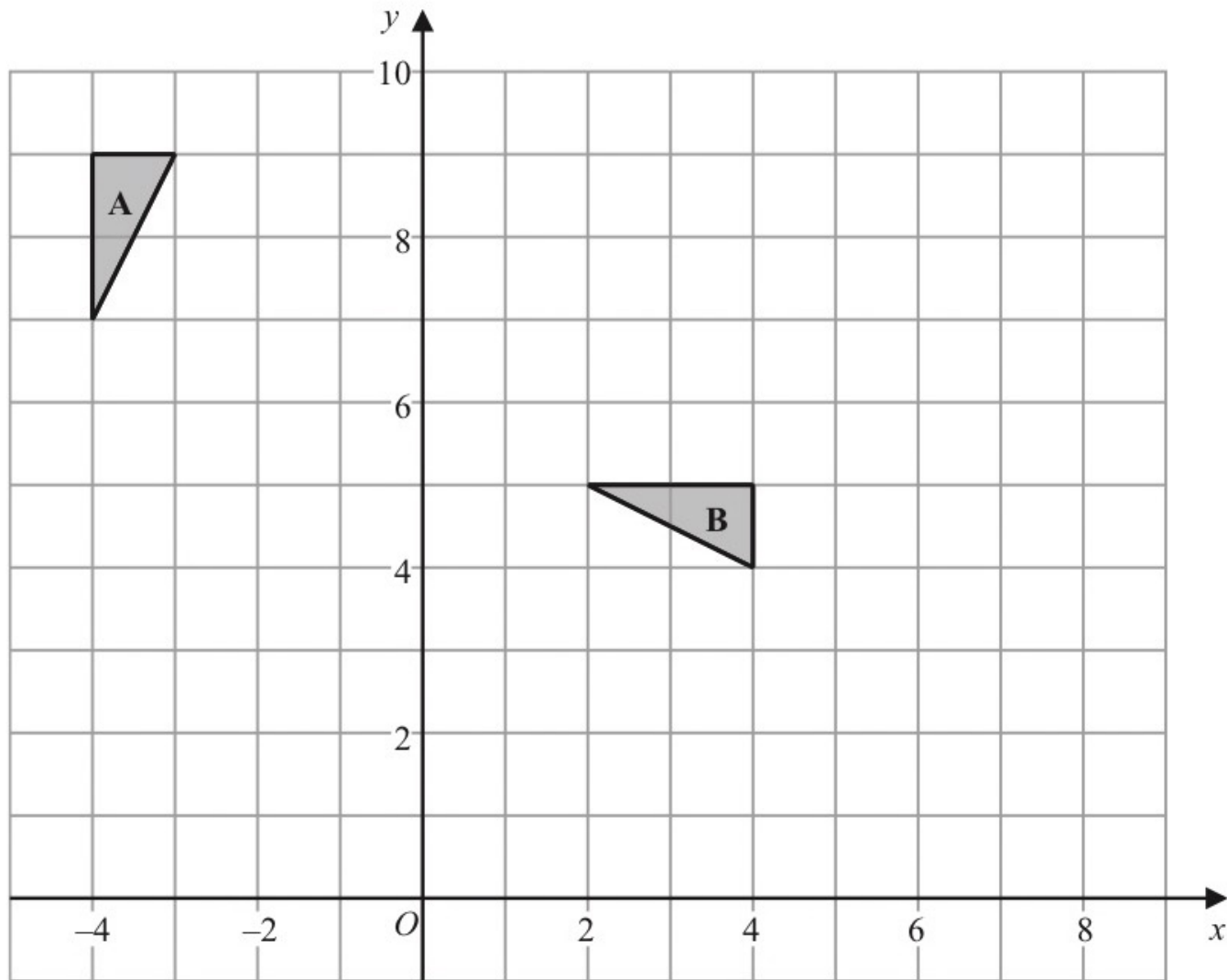

(a) Describe fully the single transformation that maps triangle **A** onto triangle **B**.

(b) On the grid, translate triangle **A** by the vector $\begin{pmatrix} 2 \\ -5 \end{pmatrix}$

Label the new triangle **C**.

6.

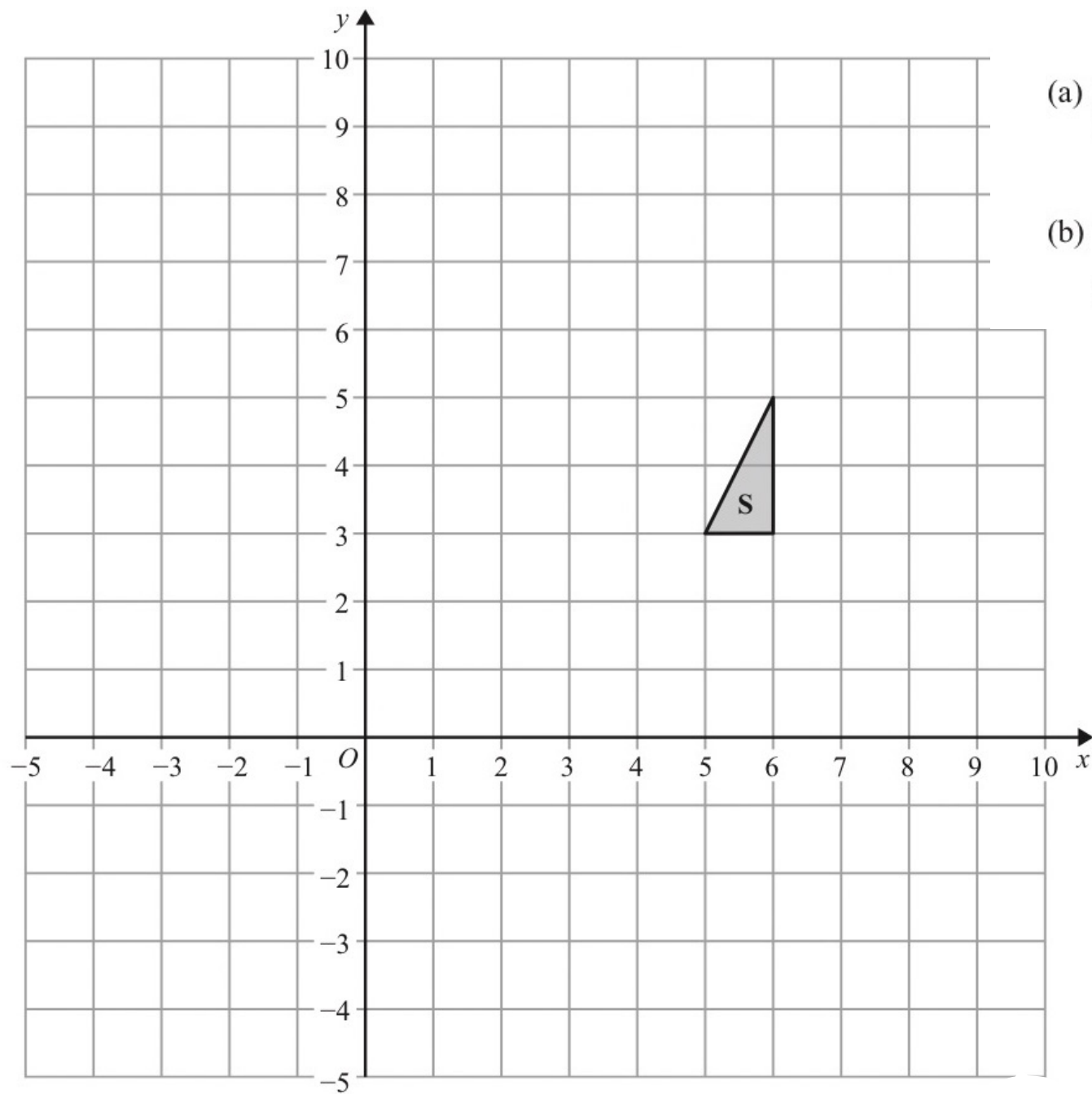

(a) Reflect triangle **S** in the line $y = x$
Label the new triangle **R**.

(b) Translate triangle **S** by the vector $\begin{pmatrix} -4 \\ -6 \end{pmatrix}$
Label the new triangle **T**.

7.

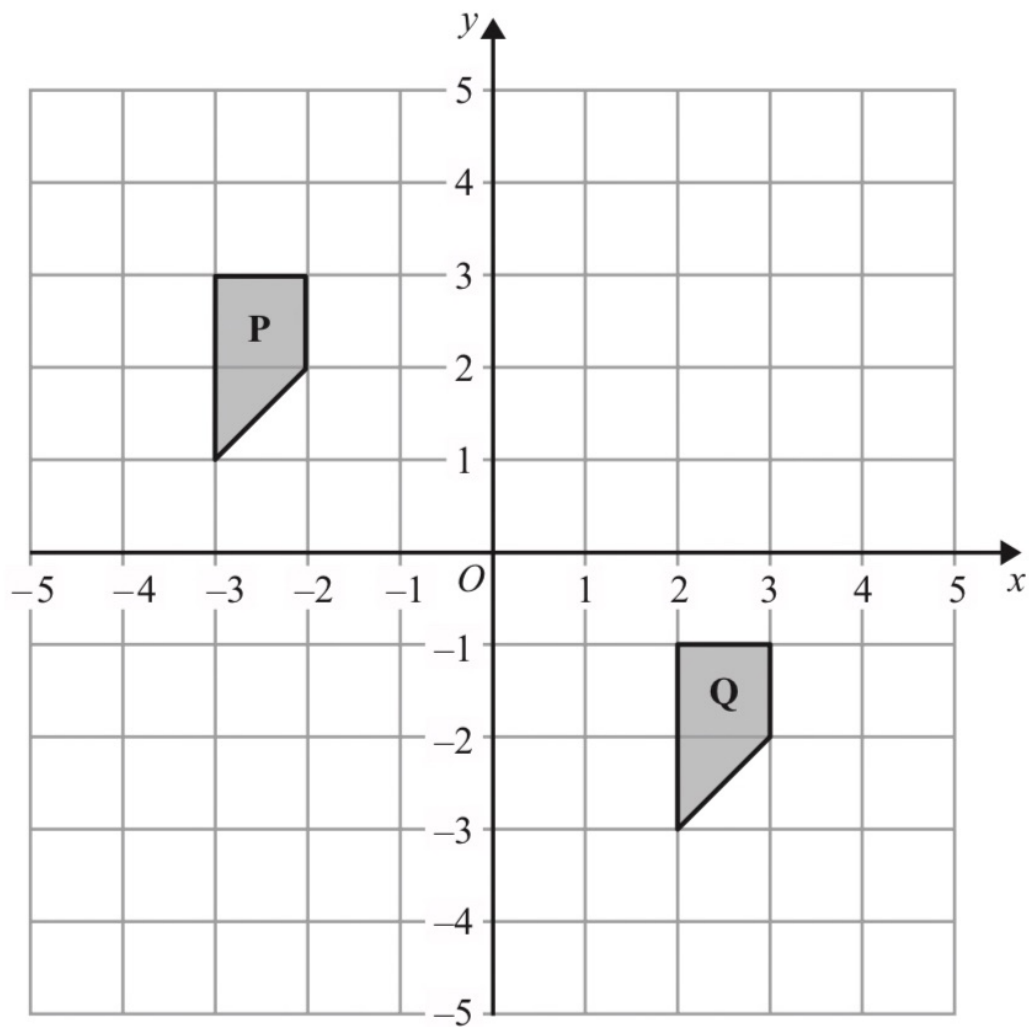

(a) Describe fully the single transformation that maps shape **P** onto shape **Q**.

.....

.....

(2)

(b) Rotate shape **Q** 90° clockwise about $(1,0)$
Label the new shape **R**.

(2)

8.

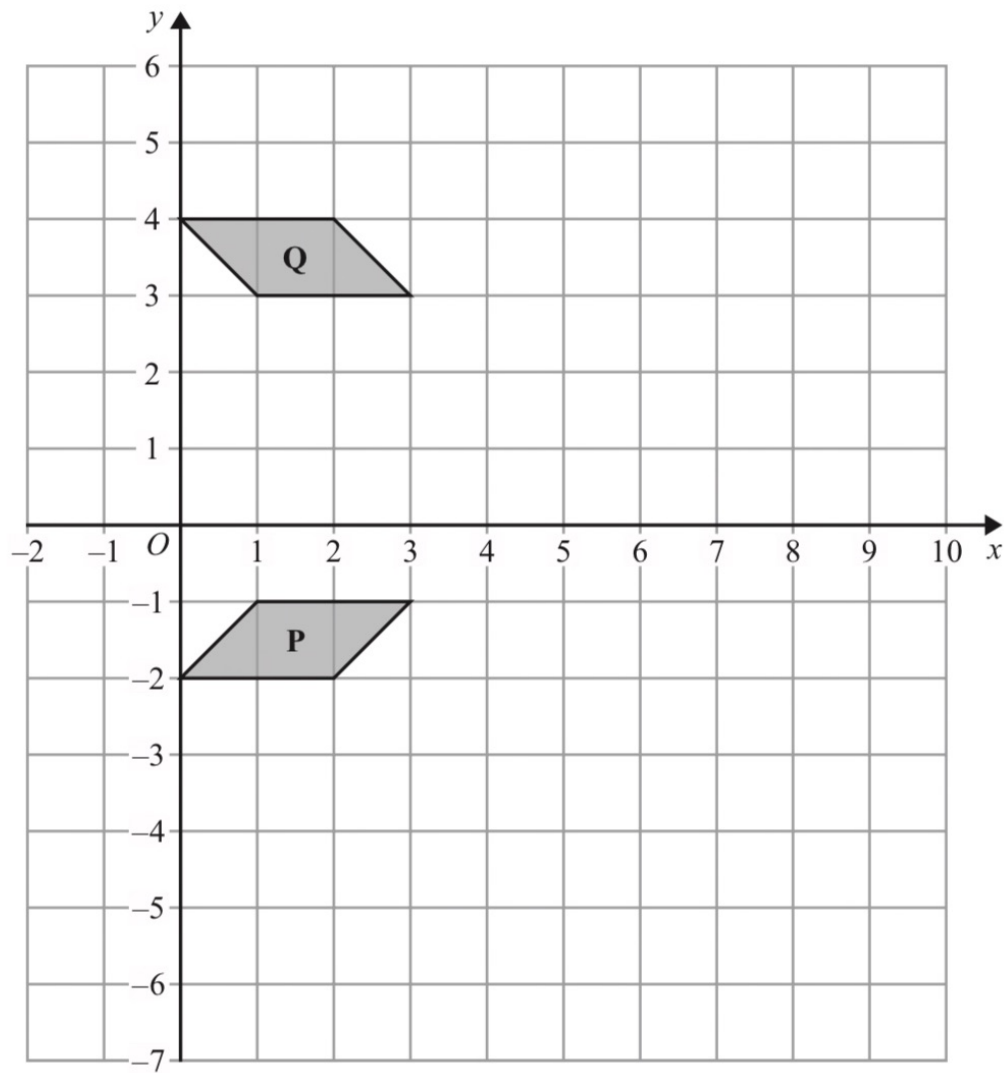

(a) Describe fully the single transformation that maps shape **P** onto shape **Q**.

.....
.....

(2)

(b) On the grid above, enlarge shape **P** with scale factor 3 and centre *O*.

(2)

9.

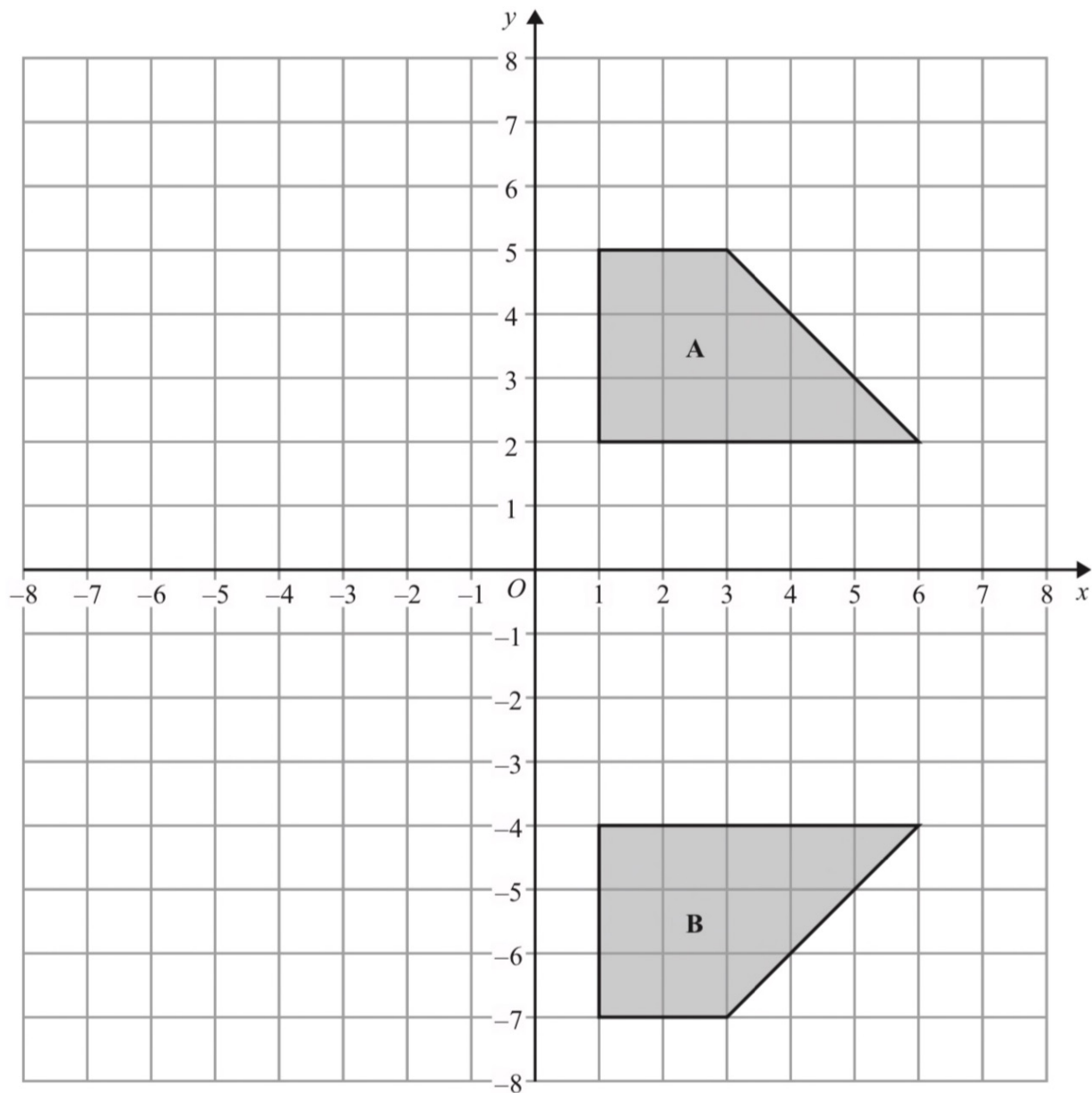

(a) Describe fully the single transformation that maps shape **A** onto shape **B**.

(b) On the grid, rotate shape **A** 90° anticlockwise about $(0, 0)$
Label the new shape **C**.