

AUTOMATED AND EMERGING TECHNOLOGIES

Chapter 6

6.1 AUTOMATED SYSTEMS

- Automated system is a combination of software and hardware that is designed and programmed to work automatically without the need of any human intervention
- Automated system requires
 - Sensors : input devices that take readings from their surroundings and send this data to a microprocessor or computer. The data from sensor is analogue, it is first converted into a digital format by an analogue-digital converter (ADC)
 - Microprocessor will process the data and take the necessary action based on programming
 - Actuator : a device to control motors, wheels, solenoids

6.1.2 AUTOMATED SYSTEM IN A NUCLEAR POWER STATION

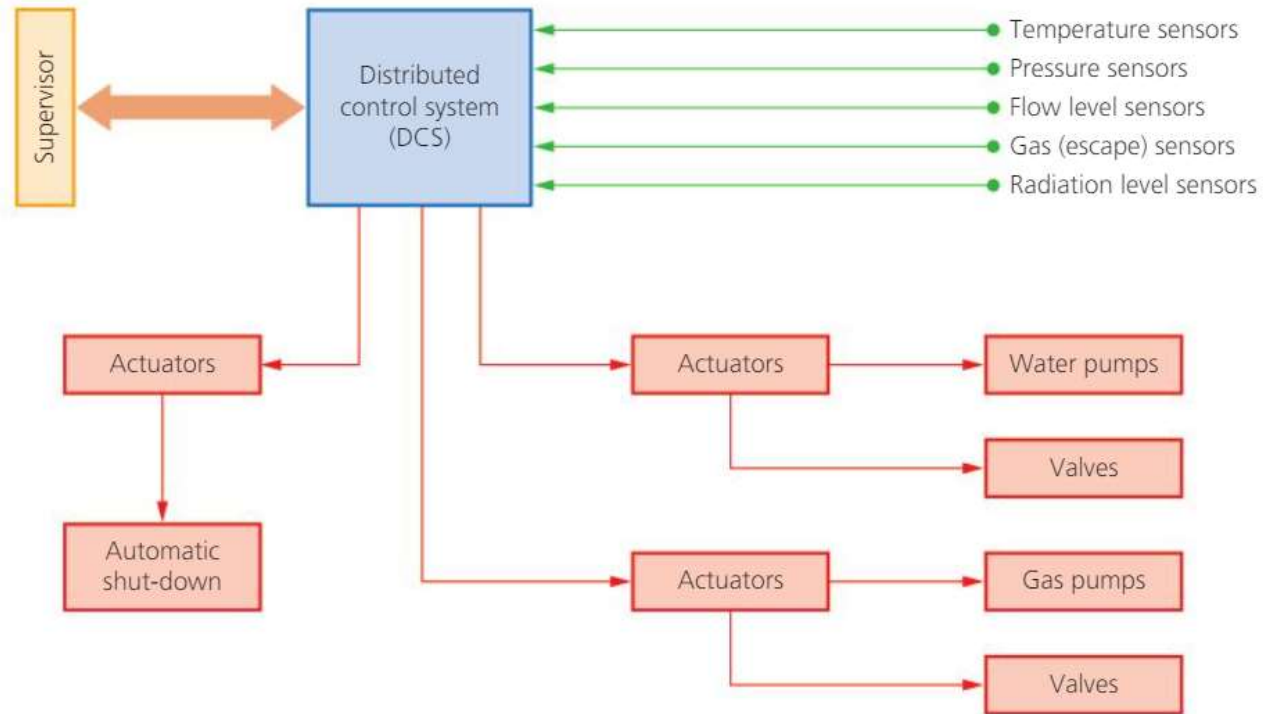

▲ Figure 6.1 Nuclear power station (automated system)

6.1.2 AUTOMATED SYSTEM IN A NUCLEAR POWER STATION

- **Advantages**

- Faster than humans
- Provide safer environment
- Quicker response
- Work 24/7
- Save cost on salary

- **Disadvantages**

- Initial set up is expensive
- Maintenance cost
- Some errors: in programming or unexpected events
- Risk of cyberattacks

6.1.2 AUTOMATED SYSTEM IN A PARACETAMOL MANUFACTURER

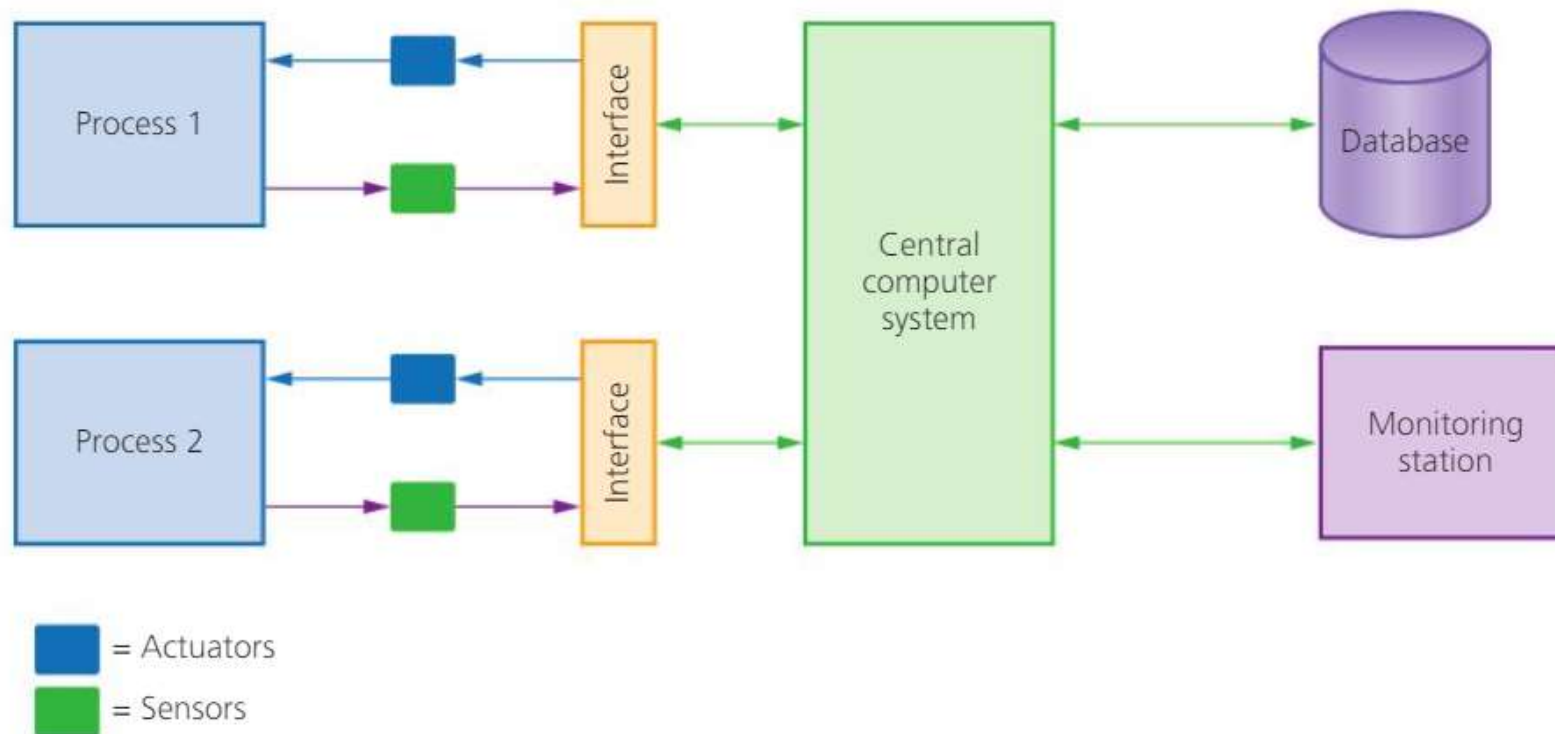

6.1.2 AUTOMATED SYSTEM IN A PARACETAMOL MANUFACTURER

- Advantages

- Faster than humans , more productivity
- Provide safer environment
- Quicker response
- Work 24/7
- Save cost on salary
- More efficient use of materials
- Consistent results

- Disadvantages

- Initial set up is expensive
- Maintenance cost
- Some errors: in programing or unexpected events

6.1.2 AUTOMATED SYSTEM IN SELF-PARKING CARS

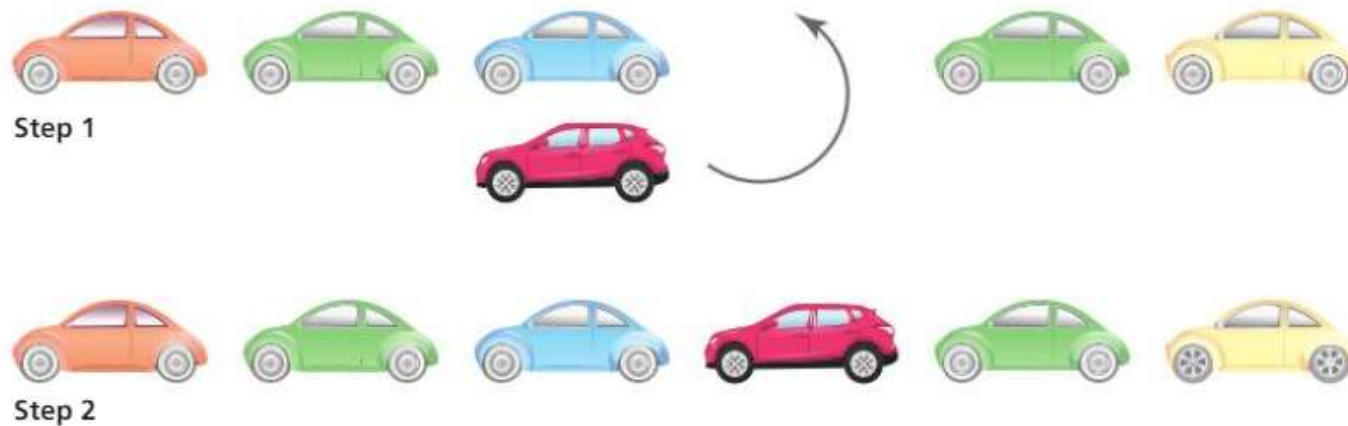

▲ Figure 6.4 Self-parking cars

6.1.2 AUTOMATED SYSTEM IN SELF-PARKING CARS

- **Advantages**

- Use less parking space since the system use optimal parking space
- Cars can fit in small space
- Faster than beginner drivers
- Fewer dents and scratches
- Safer environment

- **Disadvantages**

- Loss of driving skills
- Faulty sensors might lead to a malfunction
- Found in expensive cars
- More maintenance cost

6.1.2 AUTOMATED SYSTEM IN ADAPTIVE CRUISE CONTROL



▲ Figure 6.6 Adaptive cruise control

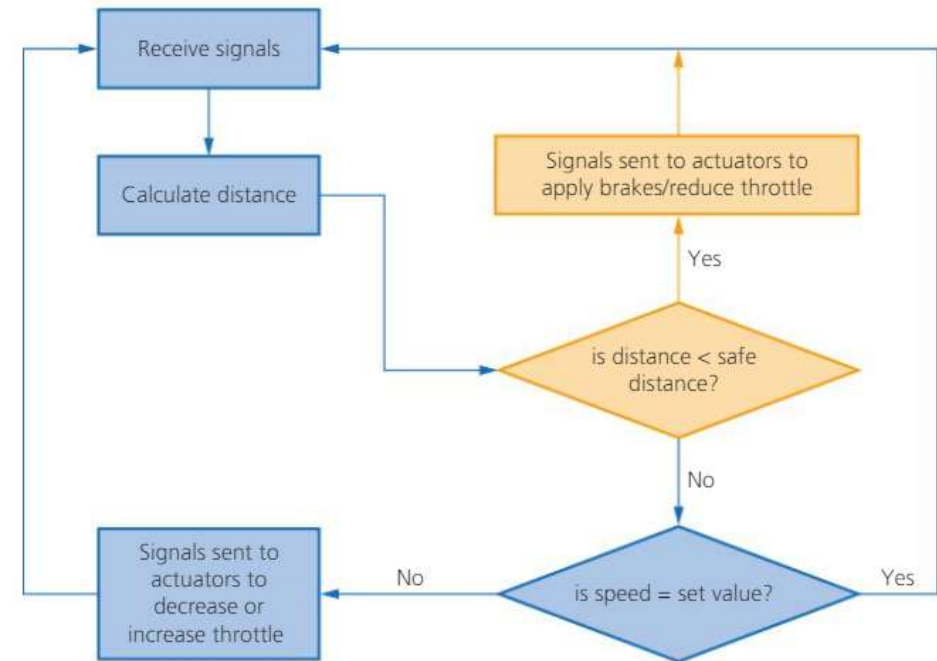

▲ Figure 6.7 Flowchart showing how adaptive cruise control works

6.1.2 AUTOMATED SYSTEM IN IRRIGATION SYSTEM

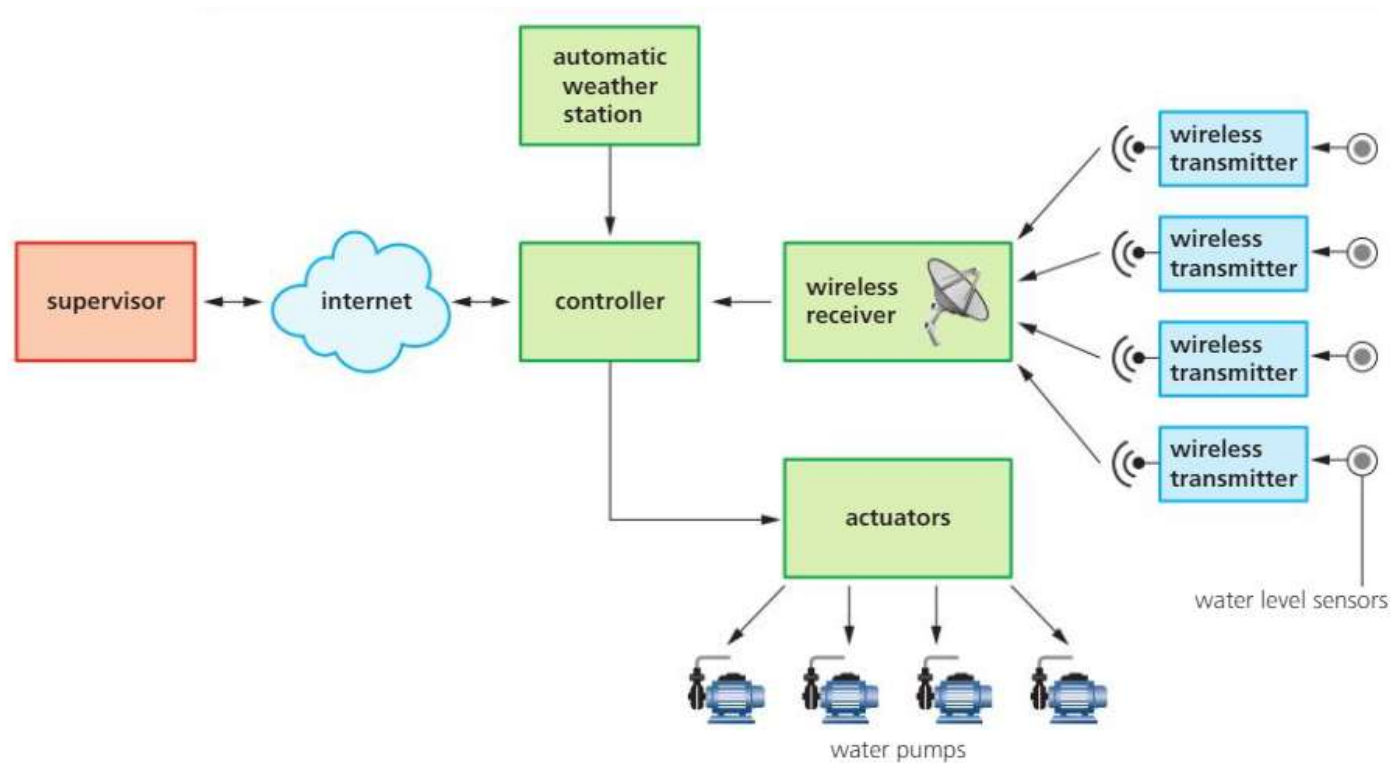

▲ Figure 6.8 Automatic irrigation system

6.1.2 AUTOMATED SYSTEM IN IRRIGATION SYSTEM

- Advantages
 - Faster than humans , more productivity
 - Provide safer environment
 - Quicker response
 - Work 24/7
 - Save cost on salary
 - More efficient use of materials
 - Consistent results
- Disadvantages
 - Initial set up is expensive
 - Maintenance cost
 - Some errors: in programing or unexpected events

6.1.2 AUTOMATED SYSTEM IN WEATHER STATIONS

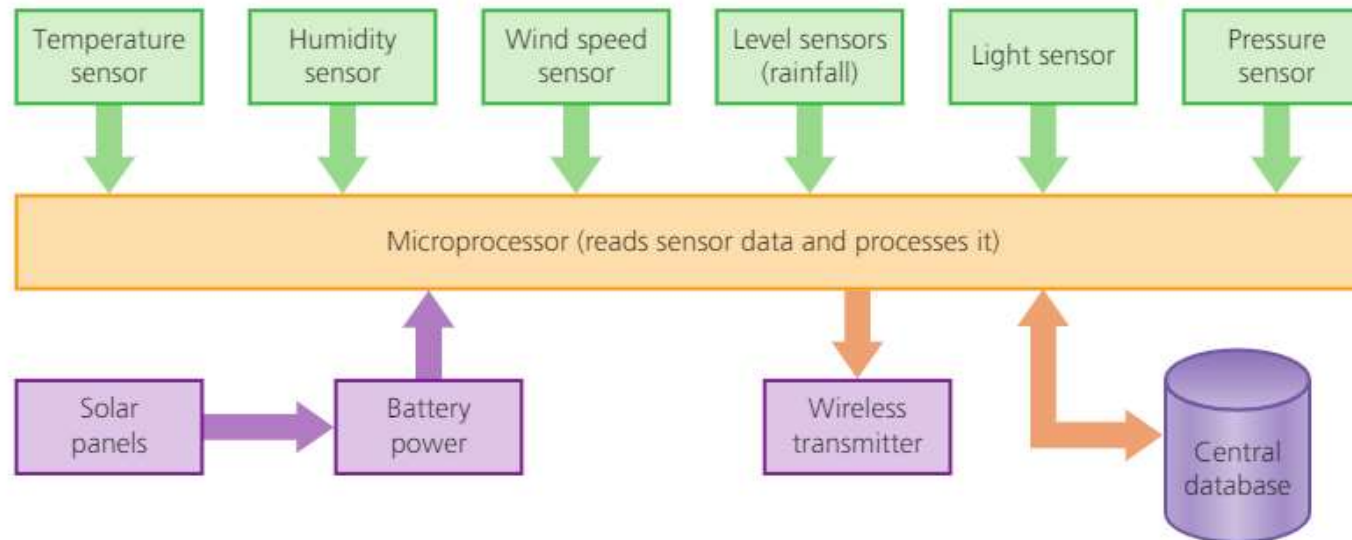

▲ Figure 6.9 Automated weather station

6.1.2 AUTOMATED SYSTEM IN LIGHTING SYSTEM IN A HOUSE

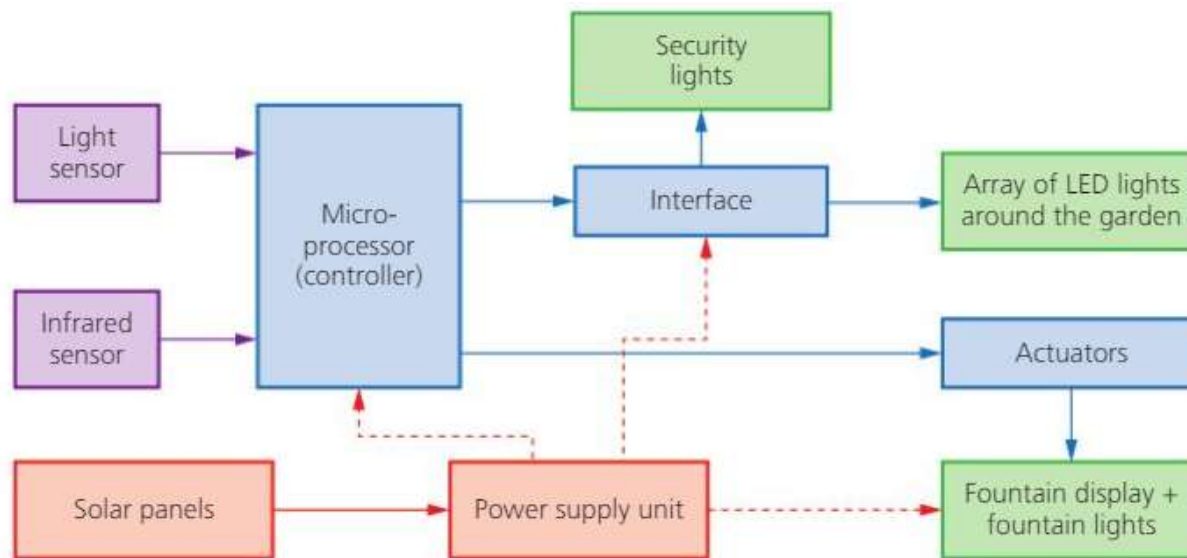

▲ Figure 6.10 Automatic lighting system

6.1.2 AUTOMATED SYSTEM IN LIGHTING SYSTEM IN A HOUSE

- **Advantages**
 - Control lights automatically
 - Reduce energy consumption (turn on when necessary)
 - Safer (wireless connection)
 - Longer light bulb life (turn on when necessary)
 - Possible to program new light displays for various occasions
- **Disadvantages**
 - Initial set up is expensive
 - Maintenance cost

6.1.2 AUTOMATED SYSTEM IN CHEMICAL PROCESS IN A LABORATORY

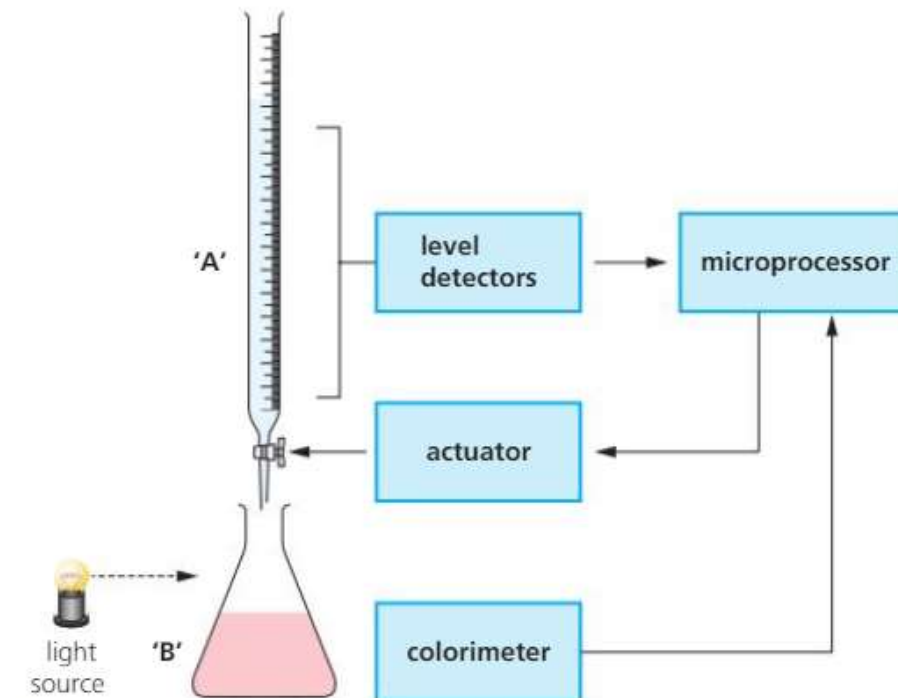

▲ Figure 6.11 Pharmaceutical laboratory experiment

6.1.2 AUTOMATED SYSTEM IN CHEMICAL PROCESS IN A LABORATORY

- Advantages
 - Faster than humans , more productivity
 - Provide safer environment
 - Quicker response
 - Work 24/7
 - Save cost on salary
 - More efficient use of materials
 - Consistent results
- Disadvantages
 - Initial set up is expensive
 - Maintenance cost
 - Some errors: in programing or unexpected events

6.1.2 ADVANTAGES AND DISADVANTAGES OF AUTOMATED SYSTEM

- Advantages
 - Safer environment
 - Faster work
 - Faster response
 - Consistent output
 - Work 24/7
 - No salary
 - Use optimal resources
- Disadvantage
 - Expensive
 - Programing might not be designed for all events
 - Maintenance cost